



C30

OWNERS MANUAL

WEB EDITION





DEAR VOLVO OWNER

THANK YOU FOR CHOOSING VOLVO

We hope you will enjoy many years of driving pleasure in your Volvo. The car has been designed for the safety and comfort of you and your passengers. Volvo is one of the safest cars in the world. Your Volvo has also been designed to satisfy all current safety and environmental requirements.

In order to increase your enjoyment of the car, we recommend that you familiarise yourself with the equipment, instructions and maintenance information contained in this owner's manual.



00 Introduction

Important information.....	8
Volvo and the environment.....	12

00



01 Safety

Seatbelts.....	16
Airbag system.....	19
Airbags.....	20
Activating/deactivating the airbag*.....	22
Side airbags (SIPS bags).....	24
Inflatable Curtain (IC).....	26
WHIPS.....	27
When the systems deploy.....	29
Crash mode.....	30
Child safety.....	31

01



02 Instruments and controls

Overview, left-hand drive cars.....	42
Overview, right-hand drive cars.....	44
Driver's door control panel.....	46
Combined instrument panel.....	47
Indicator and warning symbols.....	48
Information display.....	52
Electrical socket.....	54
Lighting panel.....	56
Left-hand stalk switch.....	61
Right-hand stalk switch.....	64
Cruise control*.....	67
Keypad in the steering wheel*.....	69
Steering wheel adjustment, hazard warning flashers.....	70
Parking brake.....	71
Power windows.....	72
Windows, rearview and door mirrors.....	74
Power sunroof*.....	78
Personal preferences.....	80
HomeLink® *.....	83

02



03 Climate control

General information on climate control.....	88
Manual climate control, AC.....	90
Electronic climate control, ECC*.....	93
Air distribution.....	96
Fuel-driven engine block heater and passenger compartment heater*.....	97
Fuel-driven auxiliary heater* (diesel).....	100



04 Interior

Front seats.....	104
Interior lighting.....	109
Storage spaces in the passenger compartment.....	112
Rear seat.....	116
Cargo area.....	118



05 Locks and alarm

Remote control key with key blade.....	124
Active locks.....	127
Keyless drive*.....	128
Battery in remote control key.....	131
Locking and unlocking.....	132
Alarm*.....	135



06 Starting and driving

General.....	140
Refuelling.....	142
Alcolock*.....	146
Starting the engine.....	150
Starting the engine – Flexifuel.....	152
Keyless drive*.....	154
Manual gearbox.....	155
Automatic gearbox.....	156
DRIVe Start-Stop*.....	161
Brake system.....	165
DSTC – Stability and traction control system*.....	167
Park Assist*.....	169
BLIS*.....	171
Towing and recovery.....	174
Start assistance.....	178
Driving with a trailer.....	179
Towing equipment*.....	181
Detachable towbar*	183
Loading.....	187
Adjusting headlamp pattern.....	188



07 Wheels and tyres

General.....	192
Tyre pressure.....	196
Warning triangle* and spare wheel *	197
Changing wheels.....	199
Emergency puncture repair*.....	201



08 Car care

Cleaning.....	208
Touching up paintwork.....	212
Rustproofing.....	214



09 Maintenance and service

Volvo service.....	218
Self-maintenance.....	219
Bonnet and engine compartment.....	220
Oils and fluids.....	222
Wiper blades.....	228
Battery.....	230
Replacing bulbs.....	234
Fuses.....	240



10 Infotainment system

General.....	250
Audio functions.....	252
Radio functions.....	257
CD functions.....	262
Menu structure – audio system.....	265
Phone functions*.....	266
Menu structure – phone*.....	273
Bluetooth handsfree*.....	276



11 Specifications

Type designation.....	284
Dimensions and weights.....	286
Engine specifications.....	289
Engine oil.....	290
Fluids and lubricants.....	292
Fuel.....	295
Wheel and tyres, dimensions and pressure	296
Electrical system.....	298
Type approval.....	300
Symbols in the display.....	301



12 Alphabetical Index

Alphabetical Index..... 304

12





Important information

Reading the Owner's Manual

Introduction

A good way of getting to know your new car is to read the owner's manual, ideally before your first journey. This will give you the opportunity to familiarise yourself with new functions, to see how best to handle the car in different situations, and to make the best use of all the car's features. Please pay attention to the safety instructions contained in the manual.

The specifications, design features and illustrations in this owner's manual are not binding. We reserve the right to make modifications without prior notice.

© Volvo Car Corporation

Option

All types of option/accessory are marked with an asterisk*.

In addition to standard equipment, this manual also describes options (factory fitted equipment) and certain accessories (retrofitted extra equipment).

The equipment described in the owner's manual is not available in all cars - they have different equipment depending on adaptations for the needs of different markets and national or local laws and regulations.

In the event of uncertainty over what is standard or an option/accessory, contact a Volvo dealer.

Special texts

WARNING

Warning texts advise of a risk of personal injury.

IMPORTANT

Important texts advise of a risk of material damage.

NOTE

NOTE texts give advice or tips that facilitate the use of features and functions for example.

Footnote

There is footnote information in the owner's manual that is located at the bottom of the page. This information is an addition to the text that it refers to via a number. If the footnote refers to text in a table then letters are used instead of numbers for referral.

Message texts

There are displays in the car that show text messages. These text messages are high-

lighted in the owner's manual by means of the text being slightly larger and printed in grey. Examples of this are in menu texts and message texts on the information display (e.g. **AUDIO SETTINGS**).

Decals

The car contains different types of decal which are designed to convey important information in a simple and clear manner. The decals in the car have the following descending degree of importance for the warning/information.

Warning for personal injury

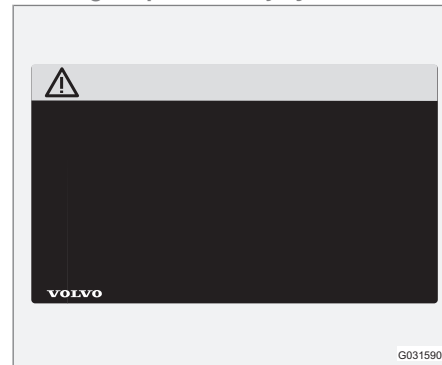

Black ISO symbols on yellow warning field, white text/image on black message field. Used to indicate the presence of danger which, if the



Important information

warning is ignored, may result in serious personal injury or fatality.

Risk of property damage

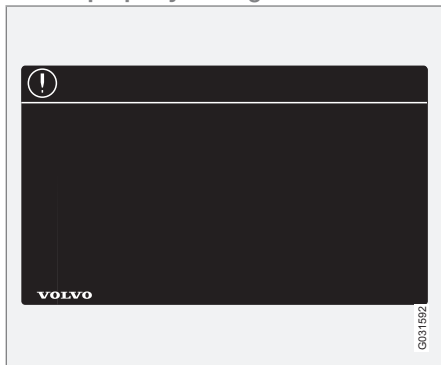

White ISO symbols and white text/image on black or blue warning field and message field. Used to indicate the presence of danger which, if the warning is ignored, may result in damage to property.

Information

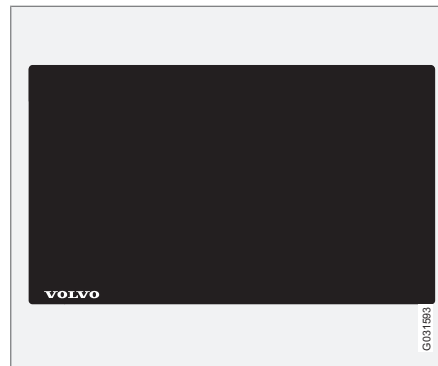

White ISO symbols and white text/image on black message field.

NOTE

The labels shown in the owner's manual are not provided as exact reproductions of those in the car. The purpose is to show their approximate appearance and location in the car. The information that applies to your car in particular is available on the label in question in your car.

Procedure lists

Procedures where action must be taken in a certain sequence are numbered in the owner's manual.

- 1 When there is a series of illustrations for step-by-step instructions each step is numbered in the same way as the corresponding illustration.
- A There are numbered lists with letters adjacent to the series of illustrations where the order of the instructions is not significant.
- 1➤ Arrows appear numbered and unnumbered and are used to illustrate a movement.
- A➤ Arrows with letters are used to clarify a movement when the reciprocal order is of no relevance.

If there is no series of illustrations for step-by-step instructions then the different steps are numbered with normal numbers.

Position lists

- 1 Red circles containing a number are used in overview images where different components are pointed out. The number recurs in the position list featured in connection with the illustration that describes the item.



Important information

Bulleted lists

A bulleted list is used when there is a list of points in the owner's manual.

Example:

- Coolant
- Engine oil

To be continued

▶▶ This symbol is located furthest down to the right when a section continues on the following page.

Recording data

Your vehicle contains a number of computers whose function is to continuously check and monitor the vehicle's operation and functionality. Some of the computers can record information during normal driving if they detect an error. In addition, information is recorded in the event of a collision or incident. Parts of the recorded information are required so that technicians can diagnose and rectify faults in the vehicle during servicing and maintenance and so that Volvo can fulfil legal requirements and other regulations. In addition to this, the information is used for research purposes by Volvo in order to continually develop quality and safety, as the information can contribute to a better understanding of the factors that cause accidents and injuries. The information

includes details of the status and functionality of various systems and modules in the vehicle with regard to engine, throttle, steering and brake systems, amongst other things. This information may include details regarding the way the driver drives the vehicle, such as vehicle speed, brake and accelerator pedal use, steering wheel movement and whether or not the driver and passengers have used their seatbelts. For the reasons given this information may be stored in the vehicle's computers for a certain length of time, but also as a result of a collision or incident. This information may be stored by Volvo as long as it can help to further develop and further enhance safety and quality and as long as there are legal requirements and other regulations that Volvo needs to consider.

Volvo will not contribute to the above-described information being disclosed to third parties without the vehicle owner's consent. However, due to national legislation and regulations Volvo may be required to disclose such information to authorities such as police authorities, or others who may assert a legal right to have access to it.

To be able to read and interpret the information recorded by the computers in the vehicle requires special technical equipment that Volvo, and workshops that have entered into agreements with Volvo, have access to. Volvo

is responsible that the information, which is transferred to Volvo during servicing and maintenance, is stored and handled in a secure manner and that the handling complies with applicable legal requirements. For further information - contact a Volvo dealer.

Accessories and extra equipment

The incorrect connection and installation of accessories can negatively affect the car's electrical system. Certain accessories only function when their associated software is installed in the car's computer system. We therefore recommend that you always contact an authorised Volvo workshop before installing accessories which are connected to or affect the electrical system.

Change of ownership for cars with Volvo On Call *

Volvo On Call is a supplemental service that consists of safety, security and comfort services. If the car has Volvo On Call and there is a change of owner, it is very important that these services are discontinued so that the former owner cannot access the services in the car. Contact the call centre by pressing the **ON CALL** button in the car or contact an authorised Volvo workshop. See also "Changing the security code" in the owner's manual for Volvo On Call.

**Important information****Information on the Internet**

At www.volvocars.com there is further information concerning your car.

A QR code reader is required to read the QR code, which is available as a supplemental program for several mobile phones. The QR code reader can be downloaded from App Store or Android Market.



QR code



Volvo and the environment

Volvo Cars' environmental philosophy



Environmental care is one of Volvo Car Corporation's core values which influence all operations. We also believe that our customers share our consideration for the environment.

Your Volvo complies with strict international environmental standards and is also manufactured in one of the cleanest and most resource-efficient plants in the world. Volvo Car Corporation has global ISO certification, which includes the environmental standard ISO 14001 covering all factories and several of our other units. We also set requirements for our partners so that they work systematically with environmental issues.

Fuel consumption

Volvo cars have competitive fuel consumption in each of their respective classes. Lower fuel consumption generally results in lower emission of the greenhouse gas, carbon dioxide.

It is possible for the driver to influence fuel consumption. For more information read under the heading, **Reducing environmental impact**.

Efficient emission control

Your Volvo is manufactured following the concept "Clean inside and out" – a concept that encompasses a clean interior environment as well as highly efficient emission control. In

many cases the exhaust emissions are well below the applicable standards.

Clean air in the passenger compartment

A passenger compartment filter prevents dust and pollen from entering the passenger compartment via the air intake.

A sophisticated air quality system, IAQS* (Interior Air Quality System) ensures that the incoming air is cleaner than the air in the traffic outside.

The system consists of an electronic sensor and a carbon filter. The incoming air is monitored continuously and if there is an increase in



Volvo and the environment

the level of certain unhealthy gases such as carbon monoxide then the air intake is closed. Such a situation may arise in heavy traffic, queues and tunnels for example.

The entry of nitrous oxides, ground-level ozone and hydrocarbons is prevented by the carbon filter.

Interior

The interior of a Volvo is designed to be pleasant and comfortable, even for people with contact allergies and for asthma sufferers. Extreme attention has been given to choosing environmentally-compatible materials.

Volvo workshops and the environment

Regular maintenance creates the conditions for a long service life and low fuel consumption for your car. In this way you contribute to a cleaner environment. When Volvo's workshops are entrusted with the service and maintenance of your car it becomes part of our system. We make clear demands regarding the way in which our workshops are designed in order to prevent spills and discharges into the environment. Our workshop staff have the knowledge and the tools required to guarantee good environmental care.

Reducing environmental impact

You can easily help reduce environmental impact - here are a few tips:

- Avoid letting the engine idle - switch off the engine when stationary for longer periods. Pay attention to local regulations.
- Drive economically - think ahead.
- Perform service and maintenance in accordance with the owner's manual's instructions - follow the Service and Warranty Booklet's recommended intervals.
- If the car is equipped with an engine block heater*, use it before starting from cold - it improves starting capacity and reduces wear in cold weather and the engine reaches normal operating temperature more quickly, which lowers consumption and reduces emissions.
- High speed increases consumption considerably due to increased wind resistance - a doubling of speed increases wind resistance 4 times.
- Always dispose of environmentally hazardous waste, such as batteries and oils, in an environmentally safe manner. Consult a workshop in the event of uncertainty about how this type of waste should be discarded - an authorised Volvo workshop is recommended.

Following this advice can save money, the planet's resources are saved, and the car's durability is extended. For more information and further advice, see the pages 140 and 295.

Recycling

As a part of Volvo's environmental work, it is important that the car is recycled in an environmentally sound manner. Almost all of the car can be recycled. The last owner of the car is therefore requested to contact a dealer for referral to a certified/approved recycling facility.

The owner's manual and the environment

The Forest Stewardship Council® symbol shows that the paper pulp in this publication comes from FSC® certified forests or other controlled sources.

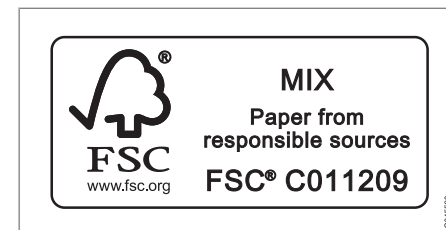

Seatbelts.....	16
Airbag system.....	19
Airbags.....	20
Activating/deactivating the airbag*	22
Side airbags (SIPS bags).....	24
Inflatable Curtain (IC).....	26
WHIPS.....	27
When the systems deploy.....	29
Crash mode.....	30
Child safety.....	31



01

SAFETY





Seatbelts

General information

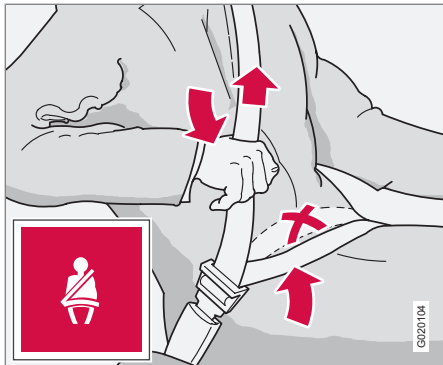

Tensioning the hip strap. The belt must be positioned low down.

Heavy braking can have serious consequences if the seatbelts are not used. Ensure that all passengers use their seatbelts. It is important that the seatbelt lies against the body so it can provide maximum protection. Do not lean the backrest too far back. The seatbelt is designed to protect in a normal seating position.

Putting on a seatbelt

- Pull the seatbelt out slowly and secure it by pressing the buckle into the lock. A loud "click" indicates that the seatbelt has locked.

Releasing the seatbelt

- Press the red lock button and then let the seatbelt retract. If the seatbelt does not retract fully, feed the seatbelt in by hand so that it does not hang loose.

The seatbelt locks and cannot be withdrawn:

- if it is pulled out too quickly
- during braking and acceleration
- if the car leans heavily.

Keep in mind the following

- do not use clips or anything else that can prevent the seatbelt from fitting properly
- ensure that the seatbelt is not twisted or caught on anything
- the hip strap must be positioned low down (not over the abdomen)
- tension the hip strap over the lap by pulling the diagonal shoulder belt as illustrated.

WARNING

The seatbelts and airbags interact. If a seatbelt is not used or is used incorrectly, this may diminish the protection provided by the airbag in the event of a collision.

WARNING

Each seatbelt is designed for only one person.

WARNING

Never modify or repair the seatbelt yourself. Volvo recommends that you contact an authorised Volvo workshop. If the seatbelt has been subjected to a major load, such as in conjunction with a collision, the entire seatbelt must be replaced. Some of the seatbelt's protective properties may have been lost even if the seatbelt does not appear damaged. The seatbelt must also be replaced if it shows signs of wear or damage. The new seatbelt must be type-approved and designed for installation at the same location as the replaced seatbelt.

WARNING

The rear seat is designed for a maximum of two passengers.



Seatbelts

Seatbelts and pregnancy



The seatbelt should always be worn during pregnancy. But it is crucial that it be worn in the correct way. The diagonal section of the seatbelt should wrap over the shoulder then be routed between the breasts and to the side of the abdomen.

The lap section of the seatbelt should lay flat over the thighs and as low as possible under the abdomen. – It must never be allowed to ride upward. Remove the slack from the seatbelt and ensure that it fits as close to the body as possible. In addition, check that there are no twists in the seatbelt.

As a pregnancy progresses, pregnant drivers should adjust their seats and steering wheel

such that they can easily maintain control of the vehicle as they drive (which means that they must be able to easily operate the foot pedals and steering wheel). They should strive to position the seat with as large a distance as possible between their abdomen and the steering wheel.

Seatbelt reminder

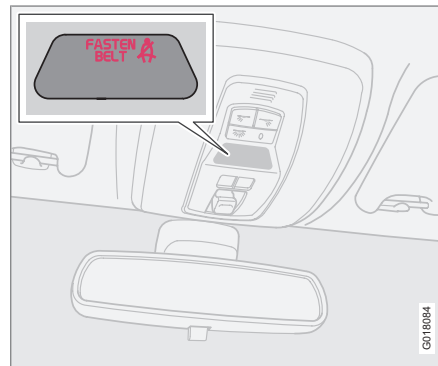

Unbelted occupants will be reminded to fasten their seatbelts by means of an audio and visual reminder. The audio reminder is speed dependent, and in some cases time dependent. The visual reminder is located in the roof console and the combined instrument panel.

Child seats are not covered by the seatbelt reminder system.

Rear seat

The seatbelt reminder in the rear seat has two subfunctions:

- Provides information on which seatbelts are being used in the rear seat. A message is shown in the information display when the seatbelts are used. The message is cleared automatically after driving for approximately 30 seconds or after pressing the indicator stalk's **READ** button.
- Provides a warning if one of the rear seatbelts is unfastened during a journey. This warning takes the form of a message on the information display along with the audio/visual signal. The warning ceases when the seatbelt is re-fastened or when acknowledged manually by pressing the **READ** button.

The message on the information display showing which seatbelts are in use is always available. Press the **READ** button to see stored messages.

Certain markets

An audio signal and indicator lamp remind the driver if not wearing a seatbelt to use one. At low speed, the audio reminder will sound for the first 6 seconds.



Seatbelts

Seatbelt tensioner

All the seatbelts are equipped with seatbelt tensioners. A mechanism in the seatbelt tensioner tightens the seatbelt in the event of a sufficiently violent collision. The seatbelt then provides more effective restraint for occupants.

WARNING

Never insert the tongue of the passenger's seatbelt into the buckle on the driver's side. Always insert the tongue of the seatbelt into the buckle on the correct side. Do not make any damages on seatbelts nor insert any foreign objects into a buckle. The seatbelts and buckles would then possibly not function as intended in the event of a collision. There is a risk of serious injury.

Seatbelt guide

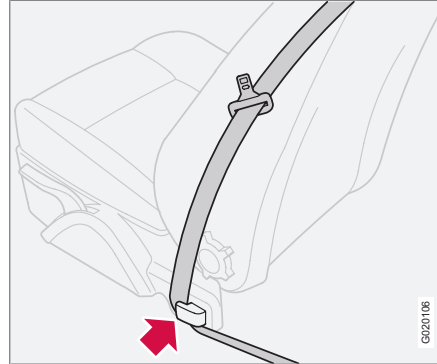

The seatbelt guide is fitted on both the driver's seat and passenger seat.

The seatbelt guide is an aid for providing better access to the seatbelt. When getting into and out of the rear seat, remove the seatbelt from the seatbelt guide and position it furthest back on the seatbelt bar. Refit the seatbelt into the seatbelt guide afterwards.



Warning symbol on the combined instrument panel

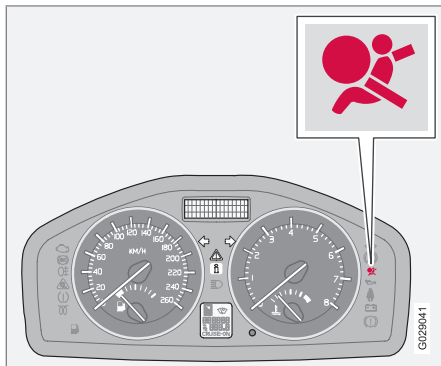

The warning symbol in the combined instrument panel illuminates when the remote control key is turned to key position **I**, **II** or **III**. The symbol goes out after approx. 6 seconds provided the airbag system is fault-free.



As well as the warning symbol, a message may appear on the display in appropriate cases. If the warning symbol malfunctions, the warning triangle illuminates and the message **SRS AIRBAG SERVICE REQUIRED** or **SRS AIRBAG SERVICE URGENT**



appears in the display. Volvo recommends that you contact an authorised Volvo workshop immediately.

WARNING

If the warning symbol for the airbag system remains illuminated or illuminates while driving, it means that the airbag system does not have full functionality. The symbol indicates a fault in the seatbelt tensioner system, SIPS, SRS or the IC system. Volvo recommends that you contact an authorised Volvo workshop immediately.



Airbags

Airbag system

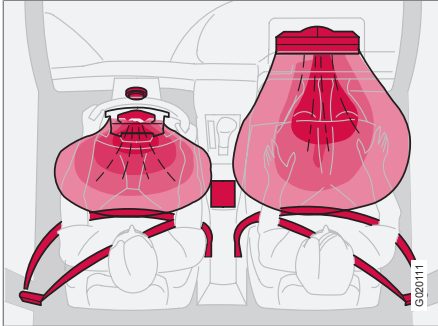

SRS system, left-hand drive

The system consists of airbags and sensors. A sufficiently violent collision trips the sensors and the airbag(s) are inflated with hot gas. To cushion the impact, the airbag deflates when compressed. When this occurs, smoke escapes into the car. This is completely normal. The entire process, including inflation and deflation of the airbag, takes place within tenths of a second.

⚠ WARNING

Volvo recommends that you contact an authorised Volvo workshop for repair. Defective work in the airbag system could cause malfunction and result in serious personal injury.

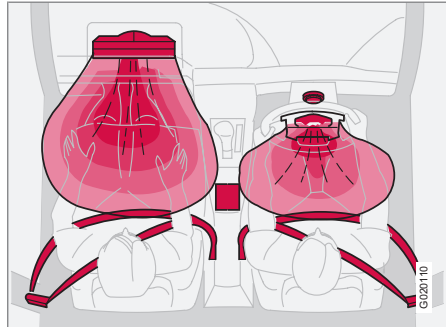

SRS system, right-hand drive

i NOTE

The sensors react differently depending on the course of the collision and whether or not the seatbelts on the driver's side and passenger side are used.

It is therefore possible that only one (or none) of the airbags may inflate in a collision. The airbag system senses the force of the collision on the car and adapts accordingly so that one or more airbags is deployed.

The capacities of the airbags are also adapted to the collision force to which they are subjected.



Airbags

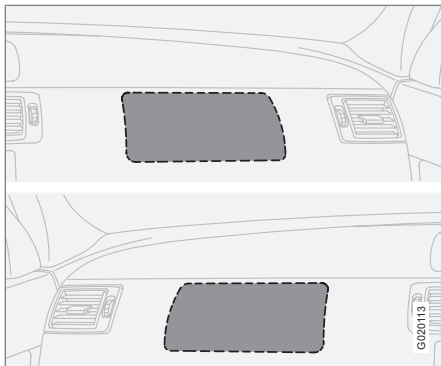

Location of the passenger airbag in left-hand drive and right-hand drive cars.

WARNING

Do not put objects in front of or above the instrument panel where the passenger airbag is located.

Airbag on the driver's side

The car has an airbag to supplement the protection afforded by the seatbelt on the driver's side. It is folded up into the centre of the steering wheel. The steering wheel is marked **SRS AIRBAG**.

WARNING

The seatbelts and airbags interact. If a seatbelt is not used or is used incorrectly, this may diminish the protection provided by the airbag in the event of a collision.

Passenger airbag

The car has an airbag to supplement the protection afforded by the seatbelt on the passenger side. It is folded up into a compartment above the glovebox. The cover panel is marked **SRS AIRBAG**.

WARNING

To minimise the risk of injury if the airbag deploys, passengers must sit as upright as possible with their feet on the floor and back against the backrest. Seatbelts must be secured.

WARNING

Never place a child in a child seat or on a booster cushion in the front seat if the airbag is activated.¹

Never allow anybody to stand or sit in front of the front passenger seat. Children under 140 cm must never sit in the front passenger seat if the airbag is activated.

Failure to follow the advice given above can endanger life.

¹ For information on activated/deactivated airbag, see page 22.



Activating/deactivating the airbag*

Key switch off - PACOS*

General information

The airbag for the front passenger seat can be deactivated if the car is equipped with a switch, PACOS (Passenger Airbag Cut Off Switch). For information on how to activate/deactivate, see under the heading Activating/deactivating.

Key switch off/switch

The switch for the passenger airbag (PACOS) is located on the passenger end of the instrument panel and is accessible when the passenger door is open, (see under the heading below, Activating/deactivating).

Check that the switch is in the required position. Volvo recommends that the key blade is used to change position.

For information on the key blade, see page 125.

WARNING

Failure to follow the advice given above can endanger life.

WARNING

If the car is equipped with a front passenger airbag, but does not have a switch (PACOS), then the airbag will always be activated.

WARNING

Never place a child in a child seat or on a booster cushion in the front seat if the airbag is activated and the symbol  in the roof console is illuminated. Failure to follow this advice could endanger the life of the child.

WARNING

Do not allow anyone to sit in the front passenger seat if the text message in the roof console indicates that the airbag is deactivated, and if the warning symbol for the airbag system is also displayed on the combined instrument panel. This indicates that there has been a severe malfunction. Volvo recommends that you visit an authorised Volvo workshop as soon as possible.

Activating/deactivating

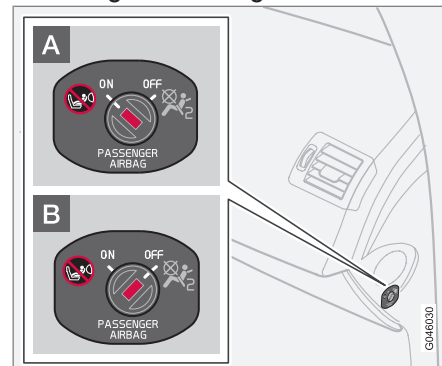

Switch location.

- A** The airbag is activated. With the switch in this position, children taller than 140 cm can sit in the front passenger seat, but never children in a child seat or on a booster cushion.
- B** The airbag is deactivated. With the switch in this position, children in a child seat or on a booster cushion can sit in the front passenger seat, but never persons taller than 140 cm.

**Activating/deactivating the airbag*****! WARNING****Activated airbag (passenger seat):**

Never place a child in a child seat or on a booster cushion on the front passenger seat when the airbag is activated. This applies to everyone shorter than 140 cm.

Deactivated airbag (passenger seat):

No one taller than 140 cm should ever sit in the front passenger seat when the airbag is deactivated.

Failure to follow the advice given above can endanger life.

Messages

Indicator showing that the passenger airbag is deactivated.

A text message and a symbol in the roof console indicate that the airbag for the front passenger seat is deactivated (see preceding illustration).

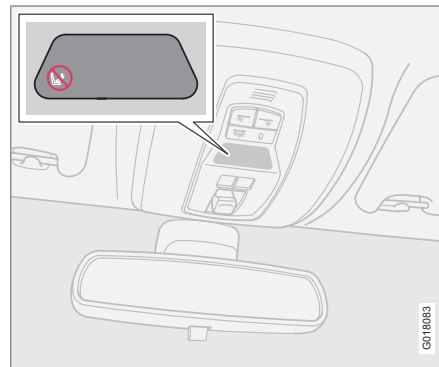

Indicator showing that the passenger airbag is activated.

A warning symbol in the roof console indicates that the airbag for the front passenger seat is activated (see preceding illustration).

i NOTE

When the remote control key is turned to key position II or III the warning symbol for the airbag is displayed on the combined instrument panel for approx. 6 seconds, see page 19.

Following which, the indicator in the roof console is illuminated showing the correct status for the front passenger seat airbag. For more information about the different key positions, see page 150.



Side airbags (SIPS bags)

Side airbag



Side airbag locations.

In a side impact collision a large proportion of the collision force is transferred by the SIPS (Side Impact Protection System) to beams, pillars, the floor, the roof and other structural parts of the body. The side airbags at the driver's and front passenger seats protect the chest area and are an important part of the SIPS. The side airbags are located in the front seat backrests.

WARNING

- Volvo recommends that repairs are only carried out by an authorised Volvo workshop. Defective work in the SIPS-bag system could cause malfunction and result in serious personal injury.
- Do not place any objects in the area between the outside of the seat and the door panel, since this area is required by the side airbag.
- Volvo recommends the use only of car seat covers approved by Volvo. Other seat covers may impede the operation of the side airbags.
- Side airbags are a supplement the seatbelts. Always use a seatbelt.

Child seats and side airbags

The protection provided by the car to children seated in a child seat or on a booster cushion is not diminished by the side airbag.

A child seat or booster cushion can be placed on the front passenger seat provided that the car does not have an activated¹ passenger airbag.

Location

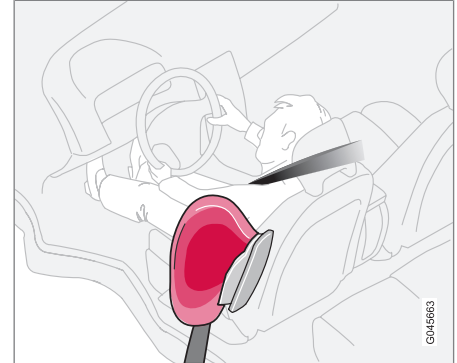

Driver's seat, left-hand drive.

¹ For information on activated/deactivated airbag (SRS), see page 22.

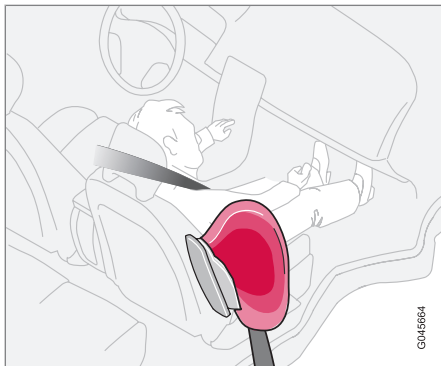
**Side airbags (SIPS bags)**

Front passenger seat, left-hand drive.

The SIPS bag system consists of side airbags and sensors. A sufficiently violent collision trips the sensors and the side airbags are inflated. The airbag inflates between the occupant and the door panel and thereby cushions the initial impact. The airbag deflates when compressed by the collision. The side airbag is normally only deployed on the side of the collision.



Inflatable Curtain (IC)

Properties

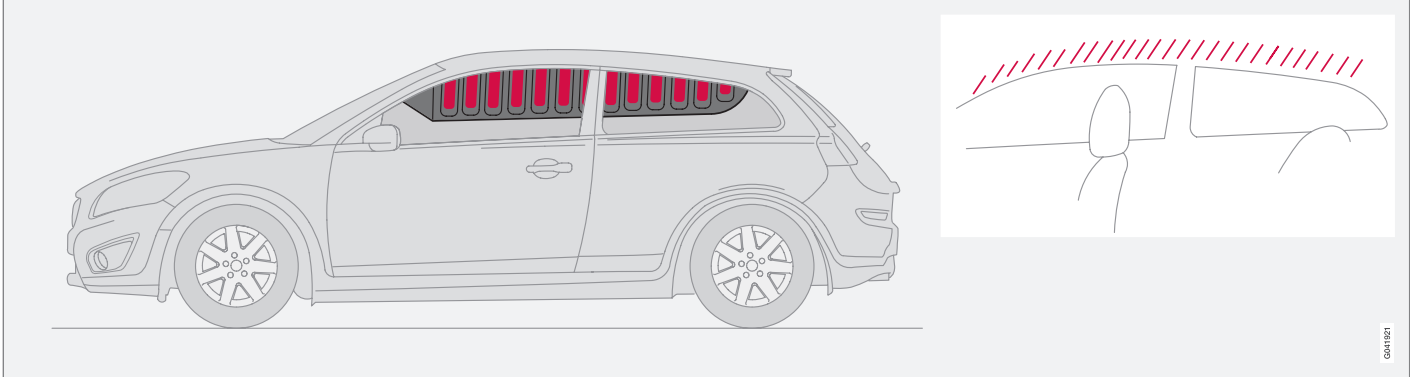

The inflatable curtain IC (Inflatable Curtain) is a part of SIPS and the airbags. It is fitted in the headlining along both sides of the roof and protects the car's occupants sitting in the outer seats. A sufficiently violent collision trips the sensors and the inflatable curtain is inflated. The inflatable curtain helps to prevent the driver and passengers from striking their heads on the inside of the car during a collision.

WARNING

Never hang or attach heavy items onto the handles in the roof. The hook is only designed for light clothing (not for solid objects such as umbrellas for example).

Do not screw or install anything onto the car's headlining, door pillars or side panels. This could compromise the intended protection. Volvo recommends that you only ever use Volvo genuine parts that are approved for placement in these areas.

WARNING

Do not load the car higher than 50 mm under the top edge of the side windows. Otherwise, the intended protection of the inflatable curtain, which is concealed in the headlining, may be compromised.

WARNING

The inflatable curtain is a supplement to the seatbelts.

Always use a seatbelt.

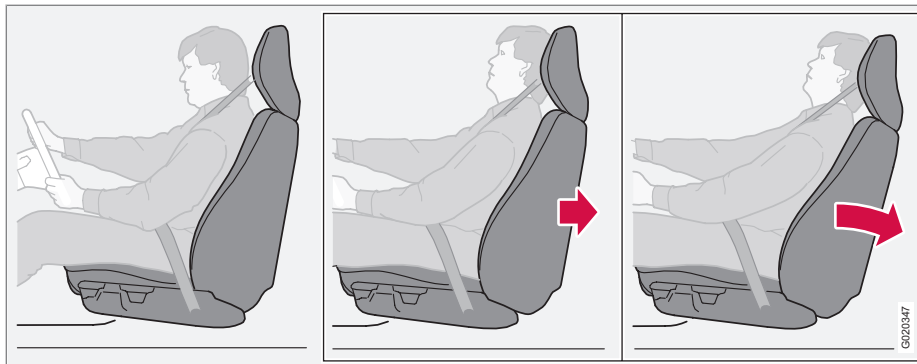

WHIPS

Protection against whiplash injury – WHIPS

The whiplash protection system (WHIPS) consists of energy absorbing backrests and specially designed head restraints for the front seats. The system is actuated by a rear-end collision, where the angle and speed of the collision, and the nature of the colliding vehicle all have an influence.

WARNING

The WHIPS system is a supplement to the seatbelts. Always use a seatbelt.

Properties of the seat

When the WHIPS system is deployed, the front seat backrests are lowered backward to alter the seating position of the driver and front seat passenger. This reduces the risk of whiplash injury.

WARNING

Never modify or repair the seat or WHIPS system yourself. Volvo recommends that you contact an authorised Volvo workshop.

WHIPS system and child seats/booster cushions

The protection provided by the car to children seated in a child seat or on a booster cushion is not diminished by the WHIPS system.

Correct seating position

For the best possible protection, the driver and front seat passenger should sit in the centre of the seat with as little space as possible between the head and the head restraint.



WHIPS

Do not obstruct the WHIPS system



Do not leave any objects on the floor behind the driver's seat/passenger seat that may prevent the WHIPS system from functioning.

WARNING

Do not squeeze rigid objects between the rear seat cushion and the front seat backrest. Make sure you do not to obstruct the function of the WHIPS system.



Do not place objects in the rear seat that may prevent the WHIPS system from functioning.

WARNING

If a rear seat backrest is folded down, the corresponding front seat must be moved forward so that it does not touch the folded backrest.

WARNING

If a seat has been subjected to extreme forces, such as due to a rear-end collision, the WHIPS system must be checked. Volvo recommends that it is checked by an authorised Volvo workshop.

Part of the WHIPS system's protective capacity may have been lost even if the seats appear to be undamaged.

Volvo recommends that you contact an authorised Volvo workshop to have the system checked even after a minor rear-end collision.



When the systems deploy

Activating the systems

System	Triggered
Seatbelt tensioner, front seat	In a frontal collision and/or side-impact accident and/or rear-end collision
Seatbelt tensioner, outside rear seat	In a frontal collision
Airbags	In a frontal collision ^A
Side airbags (SIPS)	In a side-impact accident ^A
Inflatable Curtain IC	In a side-impact accident ^A
Whiplash protection WHIPS	In a rear-end collision

^A The bodywork of the car could be greatly deformed in a collision without airbag deployment. A number of factors such as the rigidity and weight of the object hit, the speed of the car, the angle of the collision etc. affects how the different safety systems of the car are activated.

If the airbags have been deployed, the following is recommended:

- Recovering the car. Volvo recommends that you have it conveyed to an authorised Volvo workshop. Do not drive with deployed airbags.
- Volvo recommends that you engage an authorised Volvo workshop to handle the replacement of components in the car's safety systems.
- Always contact a doctor.

NOTE

The airbag, SIPS, IC and belt tensioner systems are deployed only once during a collision.

WARNING

The airbag system's control module is located in the centre console. If the centre console is drenched with water or other liquid, disconnect the battery cables. Do not attempt to start the car since the airbags may deploy. Recovering the car. Volvo recommends that you have it conveyed to an authorised Volvo workshop.

WARNING

Never drive with deployed airbags. They can make steering difficult. Other safety systems may also be damaged. The smoke and dust created when the airbags are deployed can cause skin and eye irritation/injury after intensive exposure. In case of irritation, wash with cold water. The rapid deployment sequence and airbag fabric may cause friction and skin burns.



Crash mode

Driving after a collision

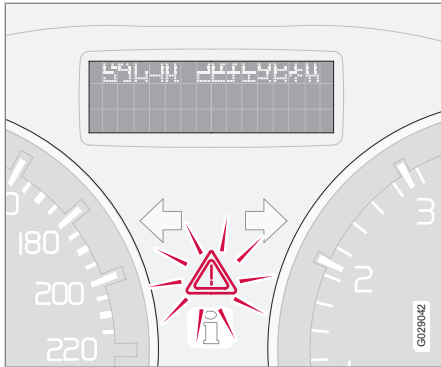

If the car is involved in a collision, the text **CRASH MODE SEE MANUAL** may appear on the information display. This means that the car has reduced functionality. Crash mode is a protective state that is enforced when the collision may have damaged any of the car's vital functions, such as the fuel lines, sensors for one of the safety systems, or the brake system.

Attempting to start the car

First, check that no fuel is leaking from the car. There must be no smell of fuel either.

If everything seems normal and you have checked for indications of fuel leakage, you may attempt to start the car.

Firstly, remove the remote control key and then reinsert it. The car's electronics will then try to reset themselves to normal mode. Then try to start the car. If **CRASH MODE SEE MANUAL** is still shown on the display then the car must not be driven or towed. Even if the car appears to be driveable, hidden damage may make the car impossible to control once moving.

Moving the car

If **NORMAL MODE** is shown after **CRASH MODE SEE MANUAL** has been reset, the car can be moved carefully out of a dangerous position. Do not move the car further than necessary.

WARNING

Never, under any circumstances, attempt to restart the car if it smells of fuel when the **CRASH MODE SEE MANUAL** message is displayed. Leave the car at once.

WARNING

If the car is in crash mode it must not be towed. It must be transported from its location. Volvo recommends that you have it conveyed to an authorised Volvo workshop.

WARNING

Never attempt to repair your car or reset the electronics yourself if the car has been in crash mode. This could result in personal injury or the car not functioning as normal. Volvo recommends that you always engage an authorised Volvo workshop to check and restore the car to **NORMAL MODE** after **CRASH MODE SEE MANUAL** has been displayed.



Child safety

Children should sit comfortably and safely

Volvo recommends that children travel in rear-facing child seats until as late an age as possible, at least until 3-4 years of age, and then front-facing booster cushions/child seats until up to 10 years of age.

The position of a child in the car and the choice of equipment are dictated by the child's weight and size, for more information, see page 32.

NOTE

Regulations regarding the placement of children in cars vary from country to country. Check what does apply.

Children of all ages and sizes must always sit correctly secured in the car. Never allow a child to sit on the knee of a passenger.

Volvo has child safety equipment (child seats, booster cushions & attachment devices) which is designed for your particular car. Using Volvo's child safety equipment provides you with optimum conditions for your child to travel safely in the car. Furthermore, the child safety equipment fits and is easy to use.

NOTE

In the event of questions when fitting child safety products, contact the manufacturer for clearer instructions.

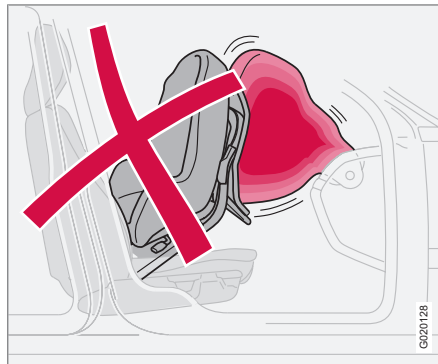
Child seats

Child seats and airbags are not compatible.

NOTE

When using child safety products it is important to read the installation instructions included with the product.

WARNING

Do not secure the straps of the child seat to the seat's horizontal adjustment bar, springs or the rails and beams under the seat. Sharp edges may damage the straps.

Look in the installation instructions for the child seat for the correct fitting.

Location of child seats

You may place:

- a child seat/booster cushion on the front passenger seat, provided the passenger airbag is not activated¹.
- one or more child seats/booster cushions in the rear seat.

Always fit child seats/booster cushions in the rear seat if the passenger airbag is activated. A child in the front passenger seat could suffer serious injury if the airbag deploys.

¹ For information on activated/deactivated airbag, see page 22.



Child safety

WARNING

Never place a child in a child seat or on a booster cushion in the front seat if the airbag is activated².

No one shorter than 140 cm should ever sit in the front passenger seat if the airbag is activated.

Failure to follow the advice given above can endanger life.

WARNING

Booster cushions/child seats with steel braces or some other design that could rest on the seatbelt buckle's opening button must not be used, as they could cause the seatbelt buckle to open accidentally.

Do not allow the upper section of the child seat to rest against the windscreen.

Label Airbag



The label is visible when the passenger door is opened, see the figure on page 22.

Recommended child seats³

Weight	Front seat ^A	Rear seat
Group 0 max. 10 kg		Volvo infant seat (Volvo Infant Seat) - rear-facing child seat, secured with the ISOFIX fixture system.
Group 0+ max. 13 kg		Type approval: E1 04301146 (L)
Group 0 max. 10 kg	Volvo infant seat (Volvo Infant Seat) - rear-facing child seat, secured with the car's seatbelt.	Volvo infant seat (Volvo Infant Seat) - rear-facing child seat, secured with the car's seatbelt.
Group 0+ max. 13 kg	Type approval: E1 04301146 (U)	Type approval: E1 04301146 (U)

² For information on activating/deactivating the airbag (SRS), see page 22.

³ With regard to other child seats the car should be included in the manufacturer's enclosed list of vehicles or be universally approved in accordance with the ECE R44 legal requirement.



Child safety

Weight	Front seat ^A	Rear seat
Group 0 max. 10 kg	Rear-facing child seat (Child Seat) - rear-facing child seat, secured with the car's seatbelt and straps. Use a protective cushion between the child seat and the instrument panel.	Rear-facing child seat (Child Seat) - rear-facing child seat, secured with the car's seatbelt, straps and support legs.
Group 0+ max. 13 kg	Type approval: E5 03135 (L)	Type approval: E5 03135 (L)
Group 0 max. 10 kg	Child seats which are universally approved. (U)	Child seats which are universally approved. (U)
Group 0+ max. 13 kg		
Group 1 9-18 kg	Volvo rear-facing/turnable child seat (Volvo Convertible Child Seat) - rear-facing child seat, secured with the car's seatbelt and straps. Type approval: E5 04192 (L)	Volvo rear-facing/turnable child seat (Volvo Convertible Child Seat) - rear-facing child seat, secured with the car's seatbelt and straps. ^B Type approval: E5 04192 (L)
Group 1 9-18 kg	Rear-facing child seat (Child Seat) - rear-facing child seat, secured with the car's seatbelt and straps. Use a protective cushion between the child seat and the instrument panel. Type approval: E5 03135 (L)	Rear-facing child seat (Child Seat) - rear-facing child seat, secured with the car's seatbelt, straps and support legs. ^B Type approval: E5 03135 (L)



01 Safety

01

Child safety

Weight	Front seat ^A	Rear seat
Group 1 9-18 kg		Britax Fixway – rear-facing child seat, secured with the ISOFIX fixture system and straps. ^B Type approval: E5 03171 (L)
Group 1 9-18 kg	Child seats which are universally approved. (U)	Child seats which are universally approved. (U)
Group 2 15-25 kg	Volvo rear-facing/turnable child seat (Volvo Convertible Child Seat) - rear-facing child seat, secured with the car's seatbelt and straps. Type approval: E5 04192 (L)	Volvo rear-facing/turnable child seat (Volvo Convertible Child Seat) - rear-facing child seat, secured with the car's seatbelt and straps ^B Type approval: E5 04192 (L)
Group 2 15-25 kg	Volvo rear-facing/turnable child seat (Volvo Convertible Child Seat) - front-facing child seat, secured with the car's seatbelt. Type approval: E5 04191 (L)	Volvo rear-facing/turnable child seat (Volvo Convertible Child Seat) - front-facing child seat, secured with the car's seatbelt. Type approval: E5 04191 (L)
Group 2/3 15-36 kg	Volvo booster seat with backrest (Volvo Booster Seat with backrest). Type approval: E1 04301169 (UF)	Volvo booster seat with backrest (Volvo Booster Seat with backrest). Type approval: E1 04301169 (UF)



Child safety

Weight	Front seat ^A	Rear seat
Group 2/3 15-36 kg	Booster cushion with and without backrest (Booster Cushion with and without backrest). Type approval: E5 03139 (UF)	Booster cushion with and without backrest (Booster Cushion with and without backrest). Type approval: E5 03139 (UF)

L: Suitable for specific child seats. These child seats may be intended for use in a special car model, limited or semi-universal categories.

U: Suitable for universally approved child seats in this weight class.

UF: Suitable for front-facing universally approved child seats in this weight class.

^A For information on activated/deactivated airbag, see page 22.

^B To install a rear-facing child seat in the rear seat, Volvo recommends that you contact an authorised Volvo dealer to have the mounting points installed.

WARNING

Never place a child in a child seat or on a booster cushion in the front seat if the airbag is activated⁴.

No one shorter than 140 cm should ever sit in the front passenger seat if the airbag is activated.

Failure to follow the advice given above can endanger life.

⁴ For information on activating/deactivating the airbag (SRS), see page 22.



Child safety

ISOFIX fixture system for child seats

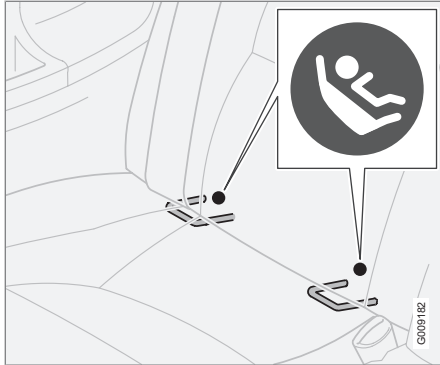

Mounting points for the ISOFIX fixture system are concealed behind the lower section of the rear seat backrest, in the outer seats.

The location of the mounting points is indicated by symbols in the backrest upholstery (see illustration above).

Press the seat cushion down to access the mounting points.

Always follow the manufacturer's installation instructions when connecting a child seat to the ISOFIX mounting points.

Size classes

Child seats are in different sizes – cars are in different sizes. This means that not all child seats are suitable for all seats in all car models.

Consequently, there is a size classification for child seats using the ISOFIX fixture system in order to assist users in choosing the correct child seat (see the following table).

Size class	Description
A	Full size, front-facing child seat
B	Reduced size (alt. 1), front-facing child seat
B1	Reduced size (alt.2), front-facing child seat
C	Full size, rear-facing child seat
D	Reduced size, rear-facing child seat
E	Rear-facing infant seat

Size class	Description
F	Transverse infant seat, left-hand
G	Transverse infant seat, right-hand

⚠ WARNING
Never place a child in the passenger seat if the car is equipped with an activated airbag.

i NOTE
If an ISOFIX child seat has no size classification then the car model must be included on the child seat's vehicle list.

i NOTE
Volvo recommends that you contact an authorised Volvo dealer for recommendations about which ISOFIX child seats Volvo recommends.



Child safety

Types of ISOFIX child seat

Type of child seat	Weight	Size class	Passenger seats for ISOFIX installation of child seats	
			Front seat	Outer rear seat
Infant seat transverse	max. 10 kg	F	X	X
		G	X	X
Infant seat, rear-facing	max. 10 kg	E	X	OK (IL)
Infant seat, rear-facing	max. 13 kg	E	X	OK (IL)
		D	X	OK ^A (IL)
		C	X	OK ^A (IL)
Child seat, rear-facing	9-18 kg	D	X	OK ^A (IL)
		C	X	OK ^A (IL)



01 Safety

01

Child safety

Type of child seat	Weight	Size class	Passenger seats for ISOFIX installation of child seats	
			Front seat	Outer rear seat
Front-facing child seat	9-18 kg	B	X	OK ^B (IUF)
		B1	X	OK ^B (IUF)
		A	X	OK ^B (IUF)

X: The ISOFIX position is not suitable for ISOFIX child seats in this weight class and/or size class.

IL: Suitable for specific ISOFIX child seats. These child seats may be intended for use in a special car model, limited or semi-universal categories.

IUF: Suitable for front-facing ISOFIX child seats that are universally approved in this weight class.

^A In order to be able to fit the infant/child seat in the rear seat, the front passenger seat has been adjusted to a location in front of centre position.

^B Volvo recommends rear-facing child seats for this group.



Upper mounting points for child seats

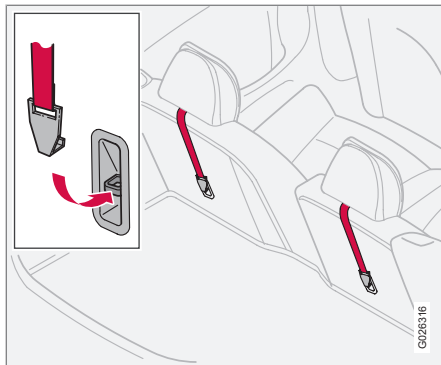

Location, upper attachment points.

The car is equipped with upper mounting points for child seats. These mounting points are located on the rear side of the rear seat.

The upper mounting points are primarily intended for use with front-facing child seats. Volvo recommends that small children should sit in rear-facing child seats to as late an age as possible.

The child seat's straps must be routed between the head restraint and the backrest.

i NOTE

Fold the head restraints in order to facilitate fitting this type of child seat in cars with folding head restraints on the outer seats.

i NOTE

For cars equipped with a cargo area cover over the cargo area, this must be removed before a child seat can be fitted in the mounting points.

For detailed information on how to secure the child seat in the upper mounting points, refer to the instructions from the child seat manufacturer.

! WARNING

The child seat's straps must always be drawn through the hole in the head restraint leg before they are tensioned at the attachment point.

Overview, left-hand drive cars.....	42
Overview, right-hand drive cars.....	44
Driver's door control panel.....	46
Combined instrument panel.....	47
Indicator and warning symbols.....	48
Information display.....	52
Electrical socket.....	54
Lighting panel.....	56
Left-hand stalk switch.....	61
Right-hand stalk switch.....	64
Cruise control*.....	67
Keypad in the steering wheel*.....	69
Steering wheel adjustment, hazard warning flashers.....	70
Parking brake.....	71
Power windows.....	72
Windows, rearview and door mirrors.....	74
Power sunroof*.....	78
Personal preferences.....	80
HomeLink® *.....	83



G041142

02

INSTRUMENTS AND CONTROLS





02 Instruments and controls

Overview, left-hand drive cars

02

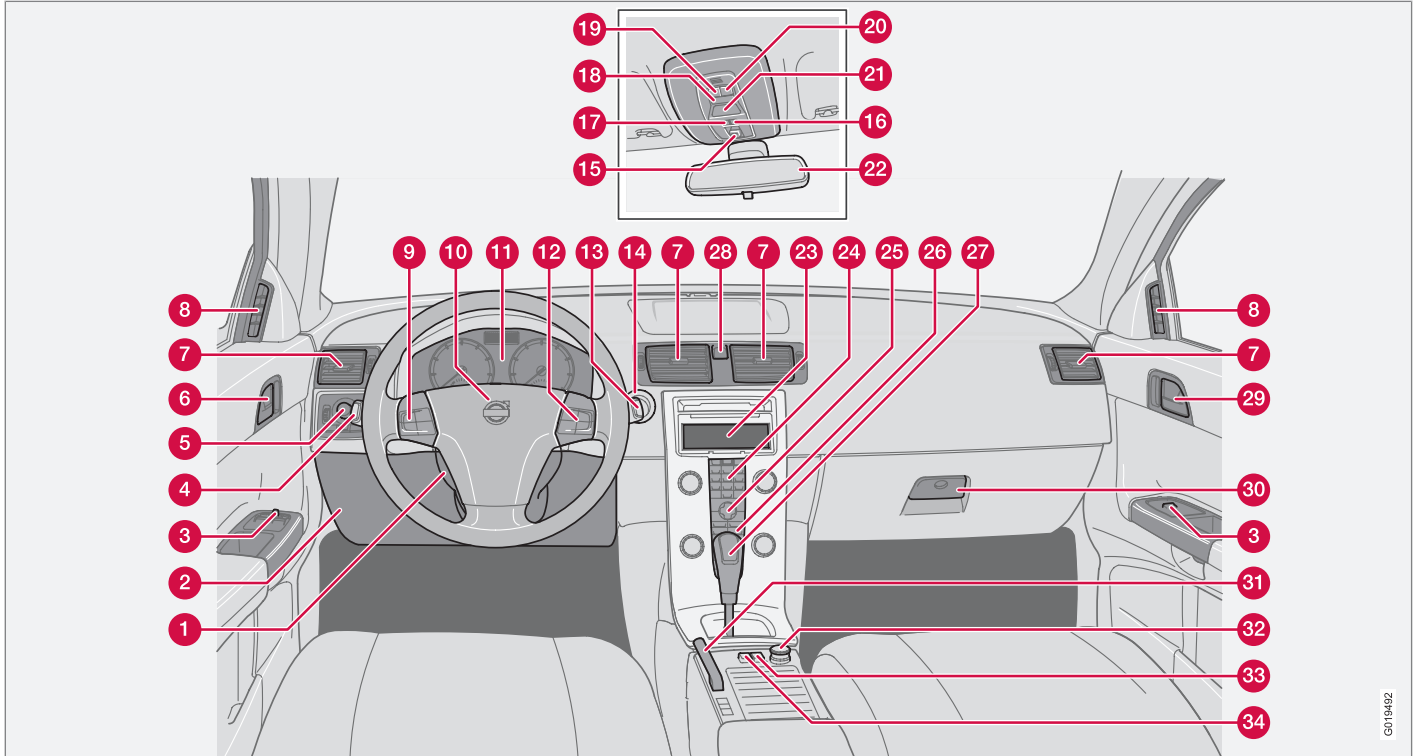

6019492



Overview, left-hand drive cars

- 1 Steering wheel adjustment
- 2 Bonnet release
- 3 Control panel
- 4 Direction indicators, main beam, trip computer
- 5 Lighting, fuel filler flap opener
- 6 Door handle, lock button.
- 7 Air vents in dashboard
- 8 Air vent for side window
- 9 Cruise control
- 10 Horn, airbag
- 11 Combined instrument panel
- 12 Keypad for infotainment system
- 13 Windscreen wipers and washer, headlamp washers
- 14 Ignition switch
- 15 Sunroof controls
- 16 No function
- 17 No function
- 18 Switch for interior lighting
- 19 Reading lamp, left-hand side
- 20 Reading lamp, right-hand side
- 21 Seatbelt reminder and passenger seat air-bag indicator
- 22 Interior rearview mirror
- 23 Display for climate control and infotainment system
- 24 Infotainment system
- 25 Controls for climate control, infotainment system and personal preferences
- 26 Climate control
- 27 Gear lever
- 28 Hazard warning flashers
- 29 Door handle
- 30 Glovebox
- 31 Parking brake
- 32 Electrical socket/cigarette lighter
- 33 Blind Spot Information System, BLIS
- 34 Switch, optional equipment



02 Instruments and controls

Overview, right-hand drive cars

02

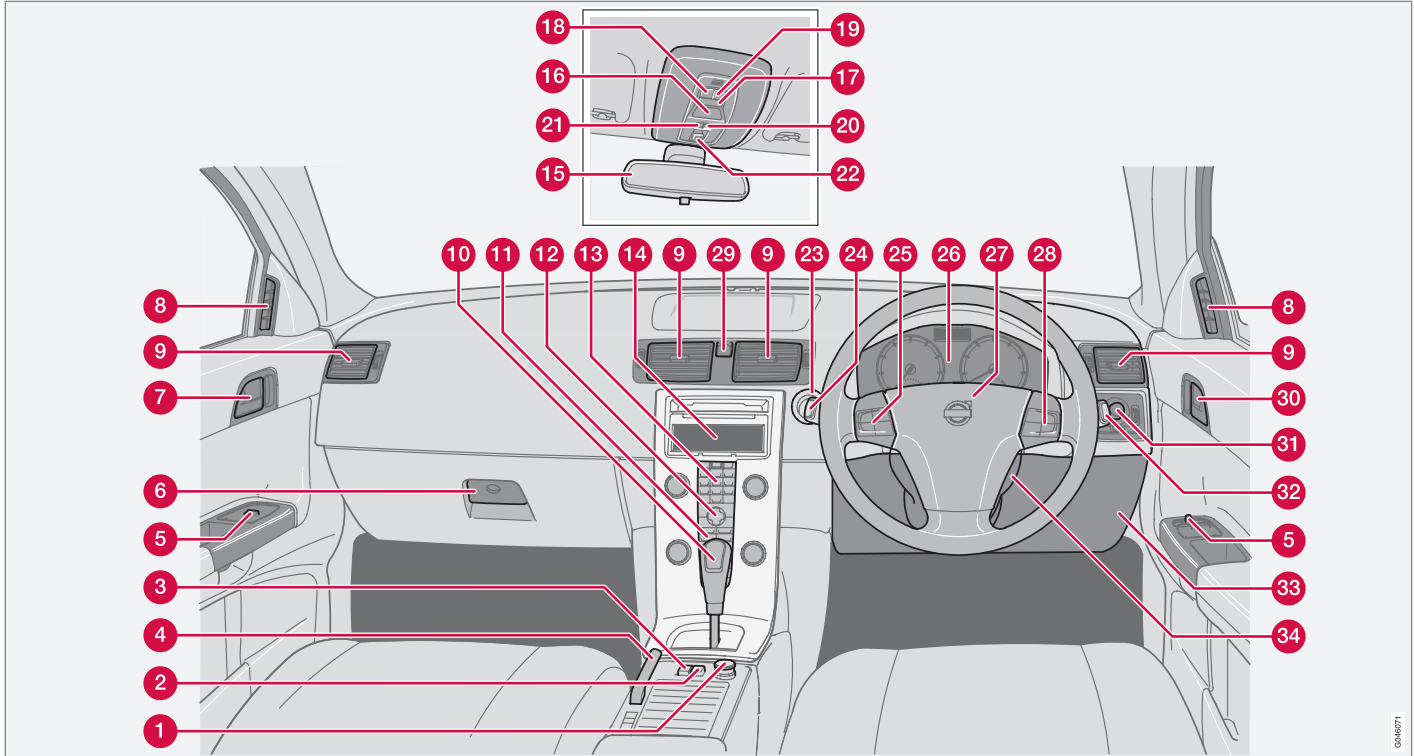

GM48771



Overview, right-hand drive cars

- 1 Electrical socket, cigarette lighter
- 2 Blind Spot Information System, BLIS
- 3 Switch, optional equipment
- 4 Parking brake
- 5 Control panel
- 6 Glovebox
- 7 Door handle
- 8 Air vent for side window
- 9 Air vents in instrument panel
- 10 Gear lever
- 11 Climate control
- 12 Controls for climate control, infotainment system and personal preferences
- 13 Infotainment system
- 14 Display for climate control and infotainment system
- 15 Interior rearview mirror
- 16 Seatbelt reminder and passenger seat airbag indicator
- 17 Switch for interior lighting
- 18 Reading lamp, left-hand side
- 19 Reading lamp, right-hand side
- 20 No function
- 21 No function
- 22 Sunroof controls
- 23 Ignition switch
- 24 Windscreen wipers and washers, headlamp washers
- 25 Cruise control
- 26 Combined instrument panel
- 27 Horn, airbag
- 28 Keypad for infotainment system
- 29 Hazard warning flashers
- 30 Door handle, lock button
- 31 Lighting, fuel filler flap opener
- 32 Direction indicators, main beam, trip computer
- 33 Bonnet release
- 34 Steering wheel adjustment



Driver's door control panel

Driver's door control panel

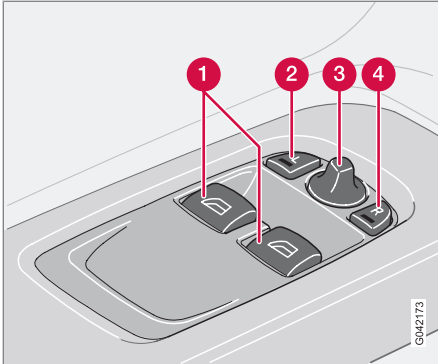

- 1 Power windows
- 2 Door mirror, left-hand side
- 3 Door mirrors, setting
- 4 Door mirror, right-hand side



Combined instrument panel

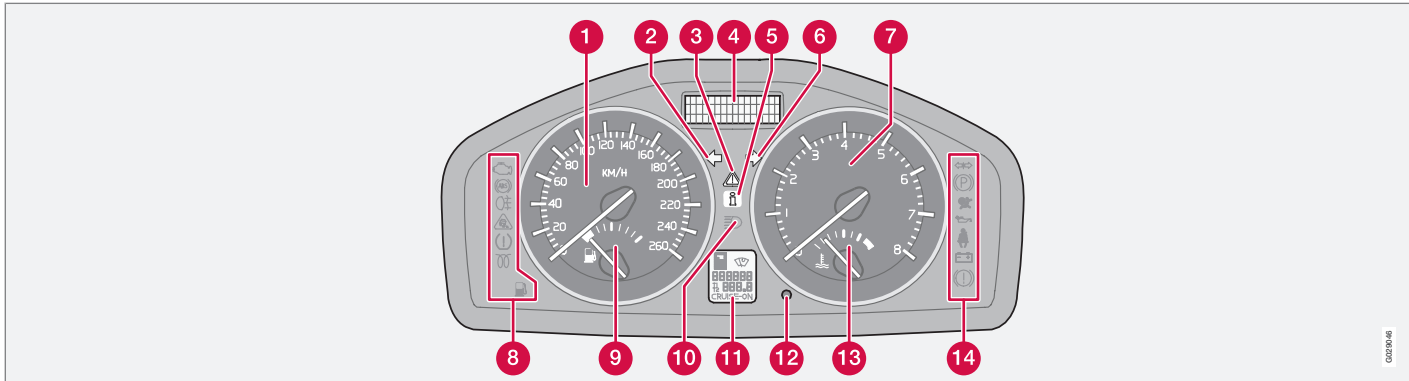

- 1** Speedometer.
- 2** Direction indicators, left.
- 3** Warning symbol.
- 4** Information display – Shows information or warning messages, outside temperature and clock. When the outside temperature is between +2 °C to -5 °C a snowflake illuminates on the display. This warns of icy roads. The outside temperature gauge may show a slightly high reading after the car has been stationary.
- 5** Information symbol.
- 6** Direction indicator, right.
- 7** Tachometer – Indicates engine speed in thousands of revolutions per minute (rpm).
- 8** Indicator and warning symbols.
- 9** Fuel gauge, see also trip computer, page 62.
- 10** Main beam indicator.
- 11** Display – Display for automatic gear position, rain sensor, odometer, trip meter and cruise control.
Also shows gear shift indicator (GSI) and gear positions in the D2 model, see page 155.
- 12** Button for trip meter – Used to measure short distances. Short presses on the button switches between the two trip meters T1 and T2. A long press (more than 2 seconds) resets an active trip meter to zero.
- 13** Temperature gauge - Used for the engine cooling system. A message will appear on the display if the temperature becomes too high and the gauge goes into the red zone. Bear in mind that extra lights placed in front of the air intake, for example, reduce the cooling capacity at high outside temperatures and high engine loads.
- 14** Indicator and warning symbols.



Indicator and warning symbols

Functionality check, symbols

All indicator and warning symbols¹ illuminate when the remote control key is turned to position **II** before starting. This is to check that the symbols are working. When the engine starts, all the symbols should go out except the parking brake symbol, which only goes out when the brake is disengaged.



If the engine does not start within five seconds, all symbols extinguish except the symbols for a fault in the car's emissions system and for low oil pressure. Certain symbols may have no function, depending on the car's specifications.



Symbols in the centre of the instrument panel

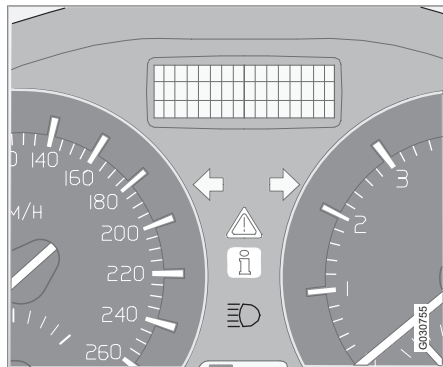

The red warning symbol illuminates when a fault has been indicated which could affect the safety and/or driveability of the car. An explanatory text is shown on the information display at the same time. The symbol remains visible until the fault has been rectified but the text message can be cleared with the **READ** button, see page 52. The warning symbol can also illuminate in conjunction with other symbols.

When the symbol illuminates:

1. Stop in a safe manner. Do not drive the car further.
2. Read the information on the information display. Implement the action in accordance with the message in the display. Clear the message using **READ**.



The yellow information symbol illuminates and a text appears on the information display. The message text is cleared using the **READ** button, see page 52, or disappears automatically after a period of time (time depending on which function is indicated).

The yellow information symbol can also illuminate in conjunction with other symbols.



NOTE

When a service message is shown, the symbol and message are cleared using the **READ** button, or disappear automatically after a time.

¹ For certain engine variants, the symbol for low oil pressure is not used. Warnings are given via display text, see page 52.



Indicator and warning symbols

Indicator symbols – left-hand side

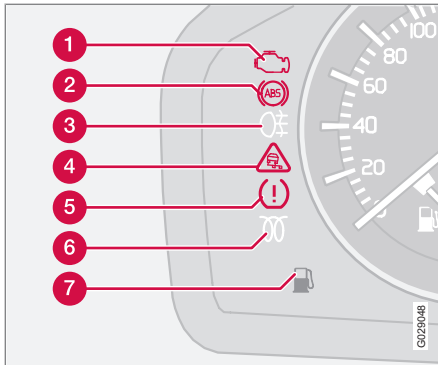

- 1 Fault in car's emissions system
- 2 ABS fault
- 3 Rear fog lamp
- 4 Stability system DSTC
- 5 No function
- 6 Engine preheater (diesel)
- 7 Low level in fuel tank

Emissions system

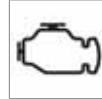

If the symbol illuminates then it may be due to a fault in the car's emissions system. Volvo recommends that you seek assistance from an authorised Volvo workshop for inspection.

ABS fault



If this symbol illuminates then the system is not working. The car's regular brake system continues to work, but without the ABS function.

1. Stop the car in a safe place and turn off the engine.
2. Restart the engine.
3. Drive to a workshop to have the ABS system checked if the symbol remains lit. Volvo recommends that you seek assistance from an authorised Volvo workshop.

Rear fog lamp



This symbol is lit when the rear fog lamp is on.

Stability system DSTC*



For information on the system's functions and symbols, see page 167.

Engine preheater (diesel)



This symbol illuminates during engine preheating. Preheating occurs when the temperature is below -2°C . The car can be started once the symbol goes out.

Low level in fuel tank



When the symbol illuminates the level in the fuel tank is low, refuel as soon as possible.

Indicator and warning symbols

Indicator symbols – right-hand side

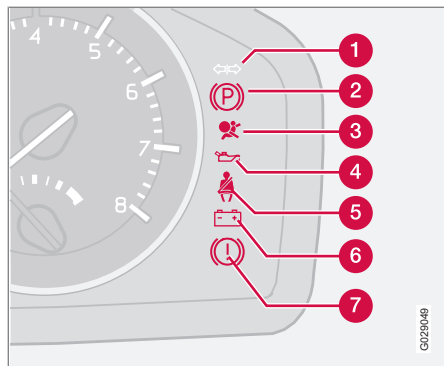

G022049

- 1 Indicator symbol for trailer
- 2 Parking brake applied
- 3 Airbags – SRS
- 4 Low oil pressure
- 5 Seatbelt reminder
- 6 Alternator not charging
- 7 Fault in brake system

Indicator symbol for trailer



This symbol flashes when the direction indicators are used and the trailer is connected. If the symbol does not flash then one of the lamps on the trailer or the car is

faulty.

Parking brake applied



The symbol illuminates when the parking brake is applied. Always pull the parking brake lever to the end position.



NOTE

The symbol illuminates irrespective of how hard the parking brake is applied.

Airbags – SRS



If this symbol remains illuminated or illuminates while driving, it means a fault has been detected in the seatbelt buckle, SRS, SIPS or IC system. Volvo recommends that drive directly to an authorised Volvo workshop for inspection.

Low oil pressure²

If this symbol illuminates during driving then the engine's oil pressure is too low. Stop the engine immediately and check the engine oil level, top up if necessary. If the

symbol illuminates and the oil level is normal Volvo recommends that you contact an authorised Volvo workshop.

Seatbelt reminder



This symbol illuminates if someone in a front seat has not put on their seatbelt or if someone in a rear seat has taken off their seatbelt.

Alternator not charging

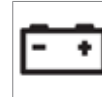

If this symbol illuminates while driving, a fault has occurred in the electrical system. Volvo recommends that you visit an authorised Volvo workshop.

Fault in brake system



If this symbol illuminates, the brake fluid level may be too low.

² For certain engine variants, the symbol for low oil pressure is not used. Warnings are given via display text, see page 52.



Indicator and warning symbols

- Stop the car in a safe place and check the level in the brake fluid reservoir, see page 226. If the reservoir level is below **MIN** then the car should not be driven further. Volvo recommends that the car is transported to an authorised Volvo workshop to have the brake system checked.



If the BRAKE and ABS symbols illuminate at the same time, there may be a fault in the brake force distribution system.



1. Stop the car in a safe place and turn off the engine.
2. Restart the engine.
3. If both symbols extinguish, continue driving.
4. If the symbols remain illuminated, check the level in the brake fluid reservoir, see page 226.
5. If the brake fluid level is normal but the symbols are still illuminated, the car can be driven, with great care, to a workshop to

have the brake system checked. Volvo recommends that you seek assistance from an authorised Volvo workshop.

6. If the level in the reservoir is below **MIN** then the car should not be driven any further. Have the car transported to a workshop to have the brake system checked. Volvo recommends that you seek assistance from an authorised Volvo workshop.



WARNING

If the BRAKE and ABS symbols are lit at the same time, there is a risk that the rear end will skid during heavy braking.

Reminder – doors not closed

If one of the doors, the bonnet³ or the tailgate is not properly closed, the driver will be reminded of this.

Low speed



If the car moves at a speed less than 5 km/h, the information symbol illuminates and **DRIVER DOOR OPEN, PASSENGER DOOR OPEN** or **BONNET OPEN** is shown on the display. Stop the car safely as soon as possible and close the door or bonnet.

High speed



If the car is moving faster than 10 km/h, the symbol illuminates and one of the texts indicated in the preceding paragraph appears on the display.

Tailgate reminder



If the tailgate is open, this information symbol will illuminate and **TAILGATE OPEN** will appear on the display.

³ Only cars with alarm.

Information display

Messages

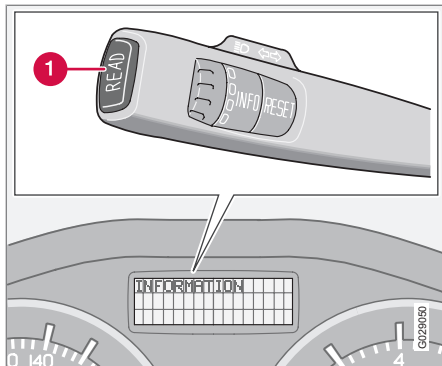

When a warning or indicator symbol illuminates the information display shows a supplementary message.

- Press the **READ** button (1).

Switch between messages with the **READ** button. Fault messages are stored in the memory until the fault is rectified.

NOTE

If a warning message appears while you are using the trip computer, the message must be read (press **READ**) before the previous activity can be resumed.

Message	Specification
STOP SAFELY^A	Stop the car in a safe manner and turn off the engine. Serious risk of damage.
SERVICE URGENT^A	Volvo recommends that an authorised Volvo workshop checks the car immediately.
SEE MANUAL^A	Read the Owner's Manual.
SERVICE REQUIRED^A	Volvo recommends that an authorised Volvo workshop checks the car as soon as possible.
HIGH ENGINE TEMP STOP ENGINE	Stop the car in a safe manner and turn off the engine. Serious risk of damage.
BOOK TIME FOR SERVICE	Time to book regular service. Volvo recommends that an authorised Volvo workshop carries out the service.

Message	Specification
TIME FOR REGULAR SERVICE	Time for regular service. Volvo recommends that an authorised Volvo workshop carries out the service. The timing is determined by the number of kilometres driven, number of months since the last service, engine running time and oil grade.
SERVICE OVERDUE	If the service intervals are not followed then the warranty does not cover any damaged parts. Volvo recommends that an authorised Volvo workshop carries out the service.
TRANSMISSION OIL CHANGE NEEDED	Volvo recommends that an authorised Volvo workshop checks the car as soon as possible.



Information display

Message	Specification
REMINDER CHECK OIL LEVEL	Check the oil level. The message is shown every 10 000 km (certain engine variants). For information on checking the oil level, see page 222.
SOOT FILTER FULL SEE OWNER MANUAL	Diesel particle filter requires regeneration, see page 144.
DSTC SPIN CON- TROL OFF	The function of the stability and traction control system is reduced, see page 168 for more variants.

Message	Specification
TRANSMISSION PERFORMANCE LOW	The gearbox cannot handle full capacity. Drive carefully until the message clears, see page 159. If shown repeatedly then Volvo recommends that an authorised Volvo workshop is contacted.

Message	Specification
TRANSMISSION OIL TEMP HIGH	Drive more smoothly or stop the car in a safe manner. Disengage the gear and run the engine at idling speed until the message clears. For more information, see page 159.
TRANSM OIL TEMP STOP SAFELY	Critical fault. Stop the car immediately in a safe manner. Volvo recommends that an authorised Volvo workshop is contacted. ^B

^A Part of message, shown together with information on where the problem has arisen.

^B For more messages concerning automatic transmission, see page 159.

Electrical socket

12 V electrical socket

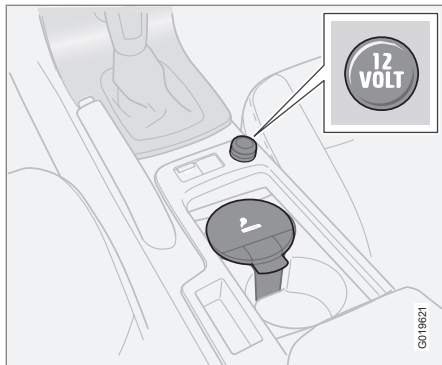

Electrical socket and cigarette lighter.

The electrical socket can be used for various accessories designed for 12 V, e.g. TV screens, music players and mobile phones. For the socket to supply current, the remote control key must be in at least position I, see page 150.

WARNING

Always leave the plug in the socket when the socket is not in use.

NOTE

Optional equipment and accessories - e.g. TV screens, music players and mobile phones - which are connected to one of the passenger compartment's 12V electrical sockets, could be activated by the climate control system, even when the remote control key has been removed or when the car is locked, for example, when the parking heater is activated at a preset time.

For this reason remove the plugs from the electrical sockets for optional equipment or accessories when not in use because the battery could be drained in the event of such an occurrence!

IMPORTANT

Max. socket is 10 A (120 W) if one socket is used at a time. If both sockets in the tunnel console are used simultaneously, 7.5 A (90 W) per socket is applicable.

If the compressor for emergency puncture repair is connected to one of the two sockets, no other current consumer must be connected to the other one.

NOTE

The compressor for temporary emergency puncture repair has been tested and approved by Volvo. For information on the use of Volvo's recommended temporary emergency puncture repair (TMK), see page 201.

Cigarette lighter*

Activate the lighter by pushing in the button. The button pops out when the lighter is hot. Pull out the lighter and light a cigarette on the heated coils.

Electrical socket in the rear seat

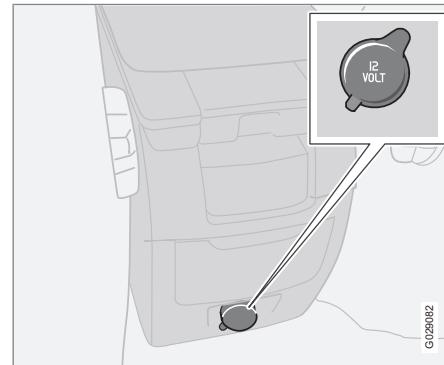

Electrical socket in the rear seat.

**Electrical socket**

The electrical socket in the rear seat can be used for various accessories, see "12 V electrical socket" above.

 NOTE

Cigarette lighter does not work in this socket.

The electrical socket is designed for 12 V. For the socket to supply current, the remote control key must be in at least position **I**, see page 150.

 WARNING

Always leave the plug in the socket when the socket is not in use.

Lighting panel

General

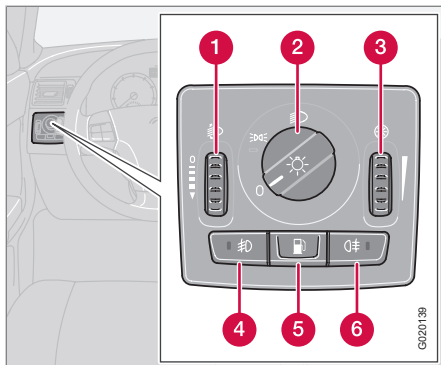
Lighting panel for halogen headlamps¹.

- 1 Thumbwheel for headlamp levelling
- 2 Light switches
- 3 Thumbwheel for adjusting display and instrument lighting
- 4 Front fog lamps*
- 5 Opening the fuel filler flap
- 6 Rear fog lamp

Headlamp levelling

The load in the car changes the vertical alignment of the headlamp beam, which could dazzle oncoming motorists. Avoid this by adjusting the height of the beam.

1. Turn the remote control key to position II.
2. Turn the headlamp control (2) to one of the end positions.
3. Roll the control (1) up or down respectively to raise or lower beam alignment.

Cars with active Xenon headlamps - ABL* have automatic headlamp levelling, so there is no control (1).

Position/parking lamps

Position/parking lamps can be switched on irrespective of remote control key position.

- Turn the headlamp control (2) to the centre position.

When the remote control key is in position II the position/parking lamps and number plate lighting are always on.

Headlamps

Automatic dipped beam*

Dipped beam comes on automatically when the remote control key is turned to position II, except when the headlamp control (2) is in the centre position. If necessary, the automatic dipped beam can be deactivated. Volvo recommends that this is performed by an authorised Volvo workshop.

Automatic dipped beam, main beam

1. Turn the remote control key to position II.
2. Dipped beam is activated by means of turning the headlamp control (2) clockwise to the end position.
3. Main beam is activated by means of moving the left-hand stalk switch towards the steering wheel to the end position and releasing it, see page 61.

The lamps are switched off automatically when the remote control key is turned to position I or 0.

¹ Description of Halogen headlamps, see page 57.



Lighting panel

Instrument lighting

The instrument lighting is switched on when the remote control key is in position II and the headlamp control (2) is in one of the end positions. The lighting is automatically dimmed during the day and can be controlled manually at night.

- Roll the control up or down (3) for brighter or dimmer lighting.

Enhanced display lighting

To facilitate reading the odometer, trip meter, clock and outside temperature gauge, these illuminate when the car is unlocked and when the remote control key is removed from the ignition switch. The displays extinguish when the car is locked.

Fog lamps

NOTE

Regulations for use of fog lamps vary from country to country.

Front fog lamps*

The front fog lamps can be switched on along with the headlamps or the position lamps/parking lamps.

- Press the button (4).

The light in the button (4) illuminates when the front fog lamps are switched on.

Rear fog lamp

The rear fog lamp can only be switched on with the headlamps or the front fog lamps.

- Press the button (6).

The rear fog lamp indicator symbol on the combined instrument panel and the light in the button (6) illuminate when the rear fog lamp is switched on.

Fuel filler flap

Press button (5) to open the fuel filler flap when the car is unlocked, see page 132.

Halogen headlamps

Lighting panel for halogen headlamps, see page 56.

Position	Halogen headlamps	Halogen headlamps with DRL ^{*A}
0	Automatic/deactivated dipped beam. Only main beam flash.	Daytime running lights
	Position/parking lamps	Daytime running lights when the car is being driven. Automatic switching to parking lights when the car is parked.



02 Instruments and controls

Lighting panel



Position	Halogen headlamps	Halogen headlamps with DRL ^{*A}
	Dipped beam. Main beam and main beam flash work in this position.	Dipped beam. Main beam and main beam flash work in this position.
A <small>OPTIONAL</small>	-	Daytime running lights during daytime driving. Automatic switching to dipped beam in poor light conditions and when windscreen wipers or rear fog lamps are activated.

^A Daytime running lights - DRL, see page 60.

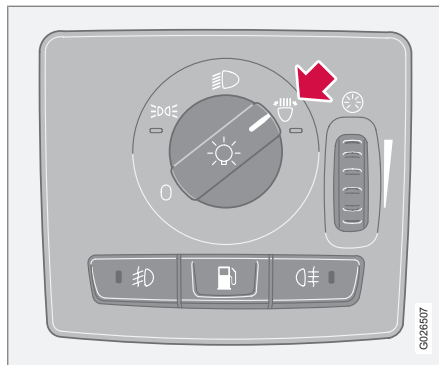
Active Xenon headlamps*



Lighting panel for active Xenon headlamps.

Position	Active Xenon headlamps	Active Xenon headlamps with DRL ^{*A}
0	Automatic/deactivated dipped beam. Only main beam flash.	Daytime running lights
	Position/parking lamps	Daytime running lights when the car is being driven. Automatic switching to parking lights when the car is parked.
	Dipped beam. Main beam and main beam flash work in this position.	Dipped beam. Main beam and main beam flash work in this position.



Lighting panel

Position	Active Xenon headlamps	Active Xenon headlamps with DRL ^{*A}
	The light from the active Xenon headlamps follows steering wheel movement.	–

Position	Active Xenon headlamps	Active Xenon headlamps with DRL ^{*A}
	–	Daytime running lights during daytime driving. Automatic switching to dipped beam in poor light conditions and when windscreen wipers or rear fog lamps are activated. The active Xenon headlamps function can also be activated in this position.

^A Daytime running lights - DRL, see page 60.

If the car is equipped with active Xenon headlamps (Active Bending Lights, ABL) the light from the headlamps follows the steering wheel movement in order to provide maximum light-

ing in bends and junctions and so provide increased safety.

The LED illuminates when the function is activated. The LED flashes and an error message is shown on the information display in the event of a malfunction. The function is only active in twilight or darkness and only when the car is moving.

The function can be deactivated/activated with the headlamp control.



Headlamp pattern with function deactivated (left) and activated (right) respectively.

Lighting panel

Daytime running lights - DRL*

To save fuel, daytime running lights (Daytime Running Light) can be selected during the day instead of the more energy-intensive dipped beam. The daytime running lights mounted in the spoiler use bright, low-energy diode technology.

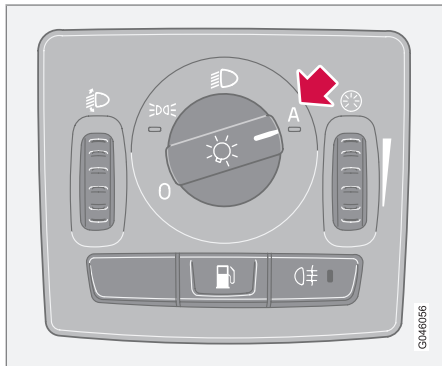

Lighting panel for halogen headlamps with DRL.

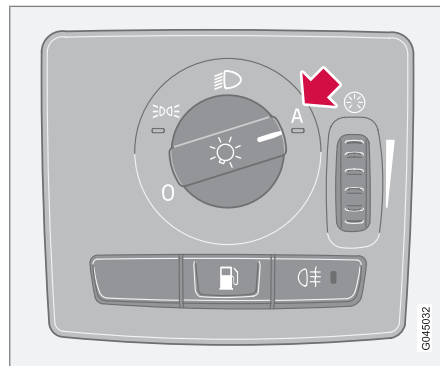

Lighting panel for active Xenon headlamps with DRL.

With the headlamp control in position **A**, the daytime running lights are activated automatically during the day. This is regulated by a light sensor which switches from daytime running lights to dipped beam off the main headlamps at dusk or when the daylight becomes too weak.

For the meaning of the headlamp control's different positions, depending on type of headlamp, see the preceding tables on pages 57 and 58.

NOTE

To achieve minimal energy consumption, the rear lights are also switched off when switching automatically from dipped beam to DRLs.

WARNING

This system help to save energy - it cannot determine in all situations when daylight is too weak or sufficiently strong, e.g. in mist and rain.

The driver is always responsible for ensuring that the car is driven with its lights in a correct state and in accordance with applicable traffic regulations.

Brake light

The brake light automatically comes on during braking. For information on the Emergency brake lights and automatic hazard warning flashers, see page 166.



Left-hand stalk switch

Stalk switch positions

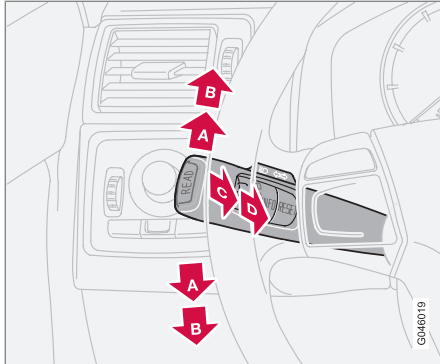

- A** Direction indicators - short flash sequence
- B** Direction indicators - continuous flash sequence
- C** Main beam flash and Home safe lighting
- D** Switching between main and dipped beam.

Direction indicators

Short flash sequence

- Move the stalk switch up or down to position (A) and release.
 - > The direction indicators flash 3 times and the stalk switch returns to its original position.

Continuous flash sequence

- Move the stalk switch up or down to end position (B).
 - > The stalk switch remains in its end position and is moved back manually, or automatically by steering wheel movement.

Main beam flash

- Move the stalk switch gently towards the steering wheel to position (C).
 - > Main beam comes on until the stalk switch is released.

Main beam flash only works when the remote control key is inserted into the ignition switch.

Switching between main and dipped beam

- Move the stalk switch to the end position (D) and release.

The remote control key must be in position II and the headlamp control in end position, see page 56, for main beam to be switched on.

Home safe lighting

Some of the exterior lighting can be kept switched on to work as home safe lighting after the car has been locked. The standard delay is 30¹ seconds, but can be changed to 60 or 90 seconds, see page 81.

1. Remove the remote control key from the ignition switch.
2. Move the stalk switch towards the steering wheel to position (C) and release.
3. Get out of the car and lock the door.

¹ Factory settings.

Left-hand stalk switch

Trip computer*

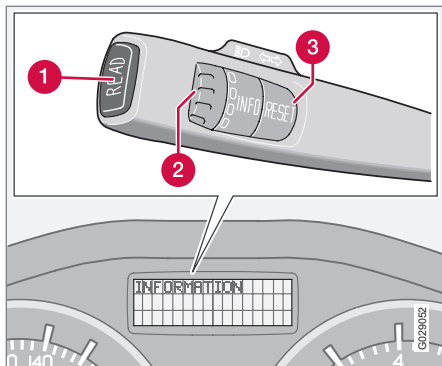

- 1 **READ** - confirms
- 2 Thumbwheel² - browse between menus and options in the trip computer list.
- 3 **RESET**² - resets

Controls

To scroll through trip computer information turn the thumbwheel either up or down in steps. The menus are in an infinite loop.

NOTE

If a warning message interrupts while you are using the trip computer, this message must be acknowledged. Acknowledge by pressing the **READ** button and revert to the trip computer function.

Functions

The trip computer displays the following information:

- --- KM/H AVERAGE SPEED
- --- KM/L INSTANTANEOUS
- --- L/100 KM AVERAGE
- --- KILOMETRES TO EMPTY TANK
- **DSTC ON** *, see page 167
- --- MPH ACTUAL SPEED³

AVERAGE SPEED

Average speed is calculated from the latest reset, which is performed with the **RESET** button.

INSTANTANEOUS

Current fuel consumption is calculated every second. The information on the display is updated every couple of seconds. When the car is stationary, "---" appears on the display.

During the period for regeneration⁴ fuel consumption may increase, see page 144.

AVERAGE

Average fuel consumption is calculated from the latest reset, which is performed with the **RESET** button.

NOTE

There may be a slight error in the reading if a fuel-driven heater is used.

KILOMETRES TO EMPTY TANK

The range to empty is calculated based on the average fuel consumption over the last 30 km. No guaranteed range remains when the display shows "**--- KILOMETRES TO EMPTY TANK**". Refuel as soon as possible.

NOTE

There may be a slight error in the reading if fuel consumption is changed due to a change in driving style or if a fuel-driven heater is used for example.

MPH ACTUAL SPEED³

Current speed is displayed in mph.

² No function in cars without trip computer, fuel-driven parking heater as well as stability and traction control system.

³ Certain markets.

⁴ Only applies to diesel cars with particle filter.

**Left-hand stalk switch****Resetting**

1. Select --- **KM/H AVERAGE SPEED** or --- **L/100 KM AVERAGE** .
2. Reset with one press of the **RESET** button.
3. One long press of the **RESET** button (at least 5 seconds) resets both average speed and average consumption simultaneously.

Right-hand stalk switch

Windscreen wipers

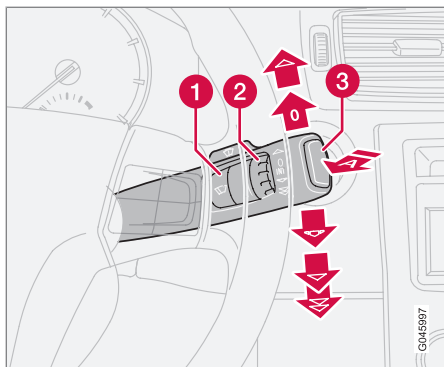

A Windscreen and headlamp washers

- 1** Rain sensor - On/Off
- 2** Thumbwheel
- 3** Wiper, rear window

Windscreen wipers off



The windscreen wipers are off when the stalk switch is in position **0**.

Single sweep

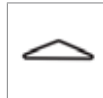

Raise the stalk switch to make a single sweep.

Intermittent wiping



You can adjust and set a suitable speed for intermittent wiping. Turn the thumbwheel (2) up for a shorter interval between sweeps. Turn it down to increase the delay.

Continuous wiping

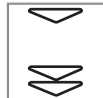

The wipers sweep at normal speed.

The wipers sweep at high speed.

! IMPORTANT

Before activating the wipers during winter – ensure that the wiper blades are not frozen in and that any snow or ice on the windscreen (and rear window) is scraped away.

! IMPORTANT

Use plenty of washer fluid when the wipers are cleaning the windscreen. The windscreen must be wet when the windscreen wipers are operating.

Windscreen/headlamp washer

Move the stalk switch toward the steering wheel to start the windscreen and headlamp washers. The wipers will make several more sweeps once the stalk switch is released.

High-pressure headlamp washing*

High-pressure headlamp washing consumes a large quantity of washer fluid. To save fluid, the headlamps are washed as follows:

Dipped beam selected with the switch on lighting panel:

The headlamps are washed the first time the windscreen is washed. Within the next ten minutes, they are washed every fifth wash cycle of the windscreen. In the event of a longer interval the headlamps are washed each time.

Parking/position lamps selected with the switch on the lighting panel:

- Active Xenon headlamps are only washed every fifth wash cycle irrespective of the time that elapses.
- Halogen headlamps are not washed.

The switch on the lighting panel is in position **0**:

- Active Xenon headlamps are only washed every fifth wash cycle irrespective of the time that elapses.
- Halogen headlamps are not washed.



Right-hand stalk switch

Reduced washing

If only approx. 1 litre of washer fluid remains in the reservoir and the message that you should fill the washer fluid is shown in the combined instrument panel's display, then the supply of washer fluid to the headlamps is switched off. This is in order to prioritise cleaning the windscreen and the visibility through it.

Rear window wiper and washer

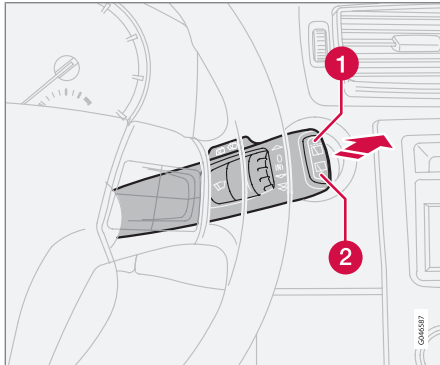

- 1 Intermittent wiping: Depress the top of the button.
- 2 Constant speed: Depress the bottom of the button.

Move the stalk switch forward to start rear window washing and wiping. The wiper blade

makes several extra sweeps once washing has finished.

i NOTE

The rear window wiper is equipped with overheating protection which means that the motor is switched off if it overheats. The rear window wiper works again after a cooling period (30 seconds or longer, depending on the heat in the motor and the outside temperature).

Wiper – reversing

Engaging reverse gear while the windscreen wipers are on initiates intermittent rear window wiping. If the rear window wiper is already on at normal speed, no change is made.

The function for intermittent wiping for reverse can be deactivated. Volvo recommends that you contact an authorised Volvo workshop.

Rain sensor*

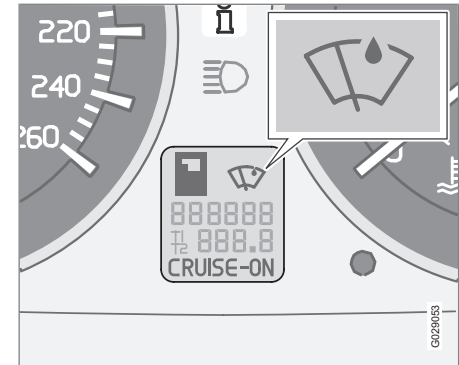

The rain sensor automatically activates the windscreen wipers based on how much water it detects on the windscreen. The sensitivity of the rain sensor can be adjusted using the thumbwheel (2), see page 64.

Turn the thumbwheel upwards for higher sensitivity and downwards for lower sensitivity, (an extra sweep is made when the thumbwheel is turned upwards).

On/Off

When activating the rain sensor, the remote control key must be in position **I** or **II** and the windscreen wiper stalk switch must be in position **0** (not activated).

* Option/accessory, for more information, see Introduction.



Right-hand stalk switch

Activating the rain sensor:

- Press the button (1), see page 64. A display symbol shows that the rain sensor is active.

To turn the rain sensor off, either:

1. Press the button (1)
2. Press the stalk switch downward to another wiper program. If the stalk switch is raised, the rain sensor will remain active, the wipers make an extra sweep and then return to rain sensor mode when the stalk is released to position **0** (not activated), see page 64.

The rain sensor is automatically deactivated when the remote control key is removed from the ignition switch or five minutes after the ignition is switched off.



IMPORTANT

At an automatic car wash: Deactivate the rain sensor by pressing the button (1) while the remote control key is in position **I** or **II**. Otherwise, the windscreen wipers could start swiping and become damaged.

selected, or the sensitivity to rain when the rain sensor is selected.

Thumbwheel

Use the thumbwheel to adjust the frequency of wiper sweeps when intermittent wiping is



Cruise control*

Activating

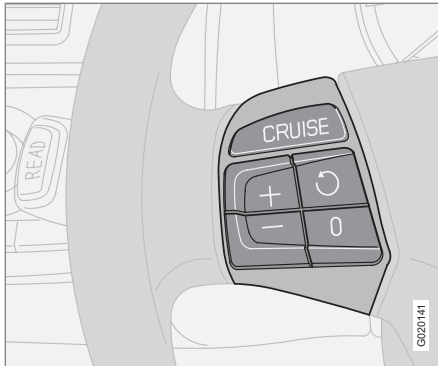

The controls for cruise control are to the left of the steering wheel.

Setting the desired speed:

1. Press the **CRUISE** button. **CRUISE** is shown on the combined instrument panel.
2. Touch **+** or **-** to lock the vehicle speed. **CRUISE-ON** appears in the combined instrument panel.

Cruise control cannot be engaged at speeds below 30 km/h or above 200 km/h.

Increasing or decreasing speed

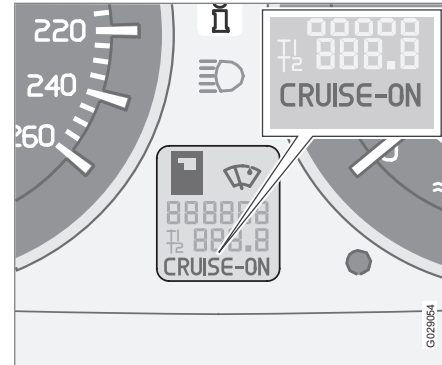

- Increase or decrease the speed by pressing and holding **+** or **-**. The speed of the car when the button is released is set as the new speed.
- A brief press (less than half a second) on **+** or **-** changes the speed by 1 km/h or 1 mph¹.

NOTE

A temporary increase in speed (less than one minute) using the accelerator, such as while overtaking, does not affect the cruise control setting. When you release the accelerator, the car will return to the programmed speed.

Temporary disengagement

- Press **0** to disengage the cruise control temporarily. **CRUISE** will be shown on the combined instrument panel. The speed set earlier is stored in the memory.

The cruise control is also temporarily disengaged when:

- the brake pedal or clutch pedal is depressed
- speed falls below 25-30 km/h¹ when travelling uphill
- the gear selector is moved to position **N**
- wheel spin or wheel lock-up occurs
- a temporary increase in speed lasts longer than one minute.

¹ Depending on engine type.



Cruise control*

Return to the set speed



– Press this button to resume the previously set speed. **CRUISE ON** appears on the combined instrument panel.

Disengaging

- Press **CRUISE** to disengage the cruise control. **CRUISE ON** clears on the combined instrument panel.



Keypad in the steering wheel*

Button functions

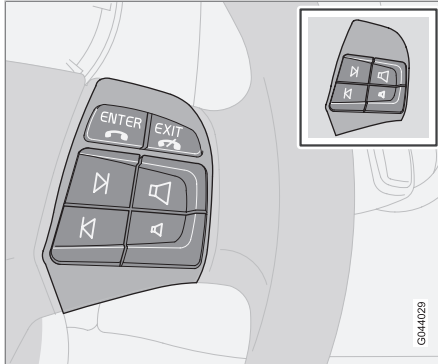

The keypad is available in two versions depending on the equipment in the car.

The four buttons at the bottom of the steering wheel keypad control the radio and the phone. The function of a button depends on which system is active. The steering wheel keypad can be used to scroll between preset stations, change CD tracks and adjust the volume.

- Press and hold one of the arrow keys to fast forward/reverse or search for the next station.

The phone must be active to make settings in the phone system. Activate the phone function with the **PHONE** button in the centre console

in order to enable control of the phone system with the arrow keys.

To return to Audio only, press **EXIT**. To return to the phone menu, press **EXIT** once again.

With the **ENTER** button you can select, activate and deactivate options in menus. The button can also be used to access the folder structure and start the playback of audio files if a disc with audio files is inserted in the CD player/CD changer*. For more information, see page 262.

Steering wheel adjustment, hazard warning flashers

Steering wheel adjustment

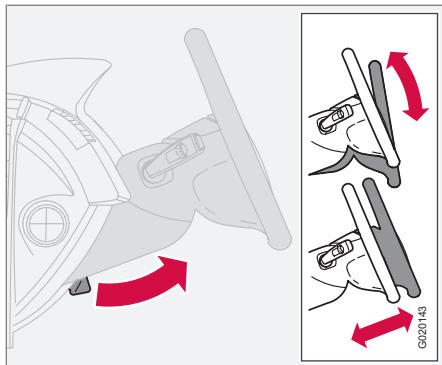

The steering wheel can be adjusted for both height and reach.

1. Pull the lever towards you to release the steering wheel.
2. Adjust the steering wheel to the position that suits you best.
3. Push back the lever to fix the steering wheel in place. If the lever is stiff, press the steering wheel lightly at the same time as you push the lever back.

 **WARNING**

Adjust the steering wheel before driving off, never while driving. Before driving, check that the steering wheel is fixed in position.

Hazard warning flashers

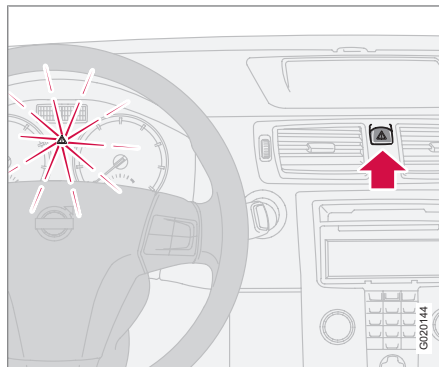

Use the hazard warning flashers (all direction indicators flash) when the car is stopped where it could be a traffic hazard or obstruction. Press the button to activate the function.

A sufficiently violent collision or heavy braking activates the hazard warning flashers automatically, see page 166. The function can be deactivated with the button.

 **NOTE**

Regulations regarding the use of hazard warning flashers vary from country to country.



Parking brake

General



Instrument panel warning symbol and warning label for risk of crushing.

The parking brake lever is located between the front seats.

WARNING

Make sure that children, other passengers or objects are not in danger of becoming trapped in any way when the parking brake is applied or released by the driver.

Applying the parking brake

1. Press the foot brake pedal down firmly.
2. Pull the lever firmly.

- > The instrument panel's warning symbol is illuminated.

NOTE

The warning lamp symbol in the combined instrument panel illuminates irrespective of how hard the parking brake is applied.

3. Release the foot brake pedal and make sure that the car is at a standstill position.
 4. If the vehicle moves then the parking brake lever must be pulled up a little bit further.
- When parking the vehicle, always engage 1st gear (for manual gearbox) or put the gear selector in position **P** (for automatic gearbox).

Parking on a hill

If the car is parked facing uphill:

- Turn the wheels **away from** the kerb.

If the car is parked facing downhill:

- Turn the wheels **towards** the kerb.

WARNING

Always apply the parking brake when parking on a slope - leaving the car in gear, or in **P** if it has automatic transmission, is not sufficient to hold the car in all situation.

Power windows

Operation

The power windows are operated using the controls in the doors. The key position must be **I** or **II** for the power windows to operate.

The windows continue to work for a limited amount of time when the car is stopped and after the remote control key is removed, provided none of the doors is opened. Operate the windows with caution.

To open a window:

- Depress the front of the control.

To close a window:

- Raise the front of the control.

Remote control and lock buttons

To operate the power windows with lock buttons and remote control, see pages 124 and 132.

WARNING

Make sure that children and other passengers cannot be trapped in any way when closing the windows. Pay close attention if the windows are closed with the remote control.

Driver's door

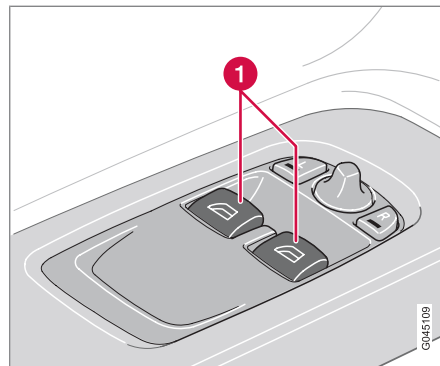

1 Controls, power windows front

The driver can operate both of the power windows from the driver's seat.

The windows can be opened and closed in two ways:

Manual operation

Depress one of the controls (1) gently or raise it gently. The power window opens or closes as long as the switch is actuated.

Automatic operation

Fully depress one of the controls (1) or raise it, then release. The side window will then open or close automatically. If the window is

obstructed by an object, the movement will stop.

WARNING

The function that interrupts the movement of the windows in the event of them being blocked works with both automatic and manual closing, although not with pinch protection deployed.

WARNING

If there are children in the car:

Remember to switch off the supply to the power windows by removing the remote control key if the driver leaves the car.

Make sure that children and other passengers cannot be trapped in any way when closing the windows.



Passenger seat

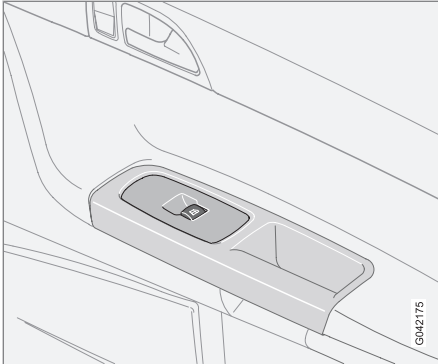

Passenger seat.

The control in the front passenger door operates that window only.

Windows, rearview and door mirrors

Interior rearview mirror

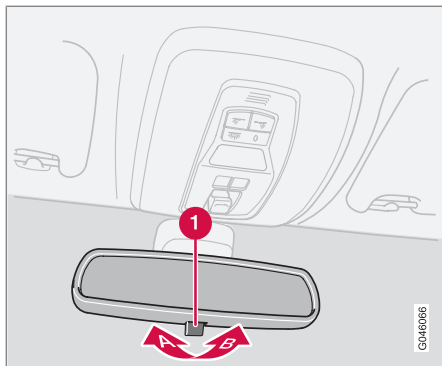

Bright light from behind could be reflected in the rearview mirror and dazzle the driver. Use dimming when disturbed by light from behind.

Dipping

- 1** Control for dimming
- A** Normal position
- B** Dimmed position.

Automatic dimming*

Bright light from behind is automatically dimmed by the rearview mirror. The control (1) is not available in mirrors with automatic dimming.

Interior rearview mirror with compass*



The upper right-hand corner of the rearview mirror has an integrated display that shows the compass direction in which the front of the car is pointing. Eight different directions are shown with English abbreviations: **N** (north), **NE** (north east), **E** (east), **SE** (south east), **S** (south), **SW** (south west), **W** (west) and **NW** (north west).

Calibrating the compass

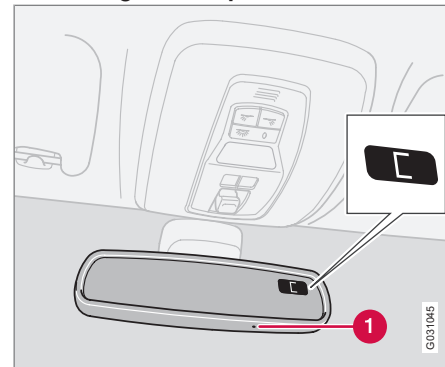

The earth is divided into 15 magnetic zones. The compass is set for the geographical area to which the car was delivered. The compass should be calibrated if the car is moved across several magnetic zones.

1. Stop the car in a wide open area with the engine running at idling speed.
2. Press and hold button (1) for at least 6 seconds. Following which, the character **C** is shown (the button is concealed so use a paper clip for example to press it in).
3. Press and hold button (1) for at least 3 seconds. The number for the current magnetic zone is displayed.



Windows, rearview and door mirrors

4. Press the button (1) repeatedly until the number for the required magnetic zone (1–15) is shown, refer to the map of magnetic zones for the compass.
5. Wait until the display returns to showing the character **C**.
6. Following which, press and hold the button in for 9 seconds and select **L** for left-hand drive cars and **R** for right-hand drive.
7. Drive slowly in a circle with a maximum speed of 10 km/h until a compass direction is shown on the display, which indicates that the calibration is complete.

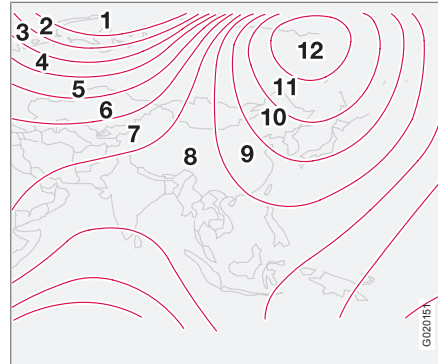

Magnetic zones, Asia.



Magnetic zones, Australia.

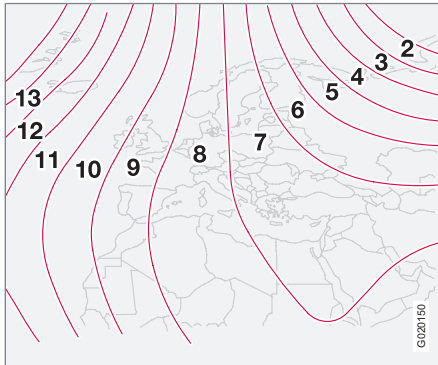

Magnetic zones, Europe.



Magnetic zones, South America.

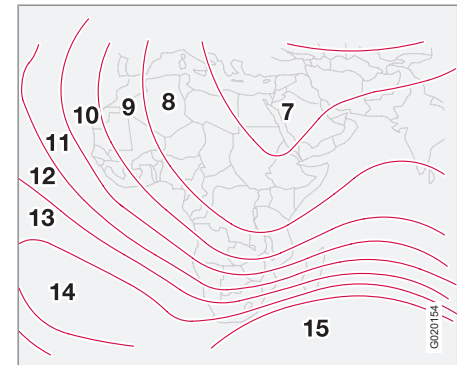

Magnetic zones, Africa.

Windows, rearview and door mirrors

Door mirrors

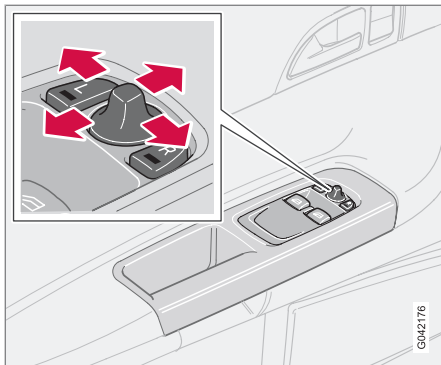

The controls for adjusting the two door mirrors are at the front of the driver's door armrest. The rearview mirrors can be operated in key position **I** and **II**.

1. Press the **L** button for the left-hand door mirror or the **R** button for the right-hand door mirror. The light on the button illuminates.
2. Adjust the position with the joystick in the centre.
3. Press the **L** or **R** button again. The light goes out.

Retractable power door mirrors*

The mirrors can be retracted for parking/driving in narrow spaces. This can be carried out in key position **I** and **II**.

Retracting the mirrors

1. Press the **L** and **R** button at the same time.
2. Release the buttons. The mirrors automatically stop in the fully retracted position.

WARNING

The door mirror on the driver's side is the wide-angled type to provide optimal vision. Objects may appear further away than they actually are.

Folding out the mirrors

1. Press the **L** and **R** button at the same time.
2. Release the buttons. The mirrors automatically stop in the fully extended position.

Automatic retracting/extending

When the car is locked/unlocked with the remote control or using the Keyless-system, see page 128, the door mirrors are automatically retracted/extended.

NOTE

The door mirrors will not be extended automatically during unlocking if they were retracted using the controls in the door.

If the car is locked with the remote control and is then started, the door mirrors will still be extended.

The function can be activated/deactivated under **Car settings...** → **Mirror fold on locking**, see page 81 for a description of the menu system.

Resetting to neutral

Mirrors that have been moved out of position by an external force must be reset to the neutral position for electric retracting and extending to work.

1. Use the **L** and **R** buttons to retract the mirrors.
2. Extend the mirrors again with the **L** and **R** button. The mirrors are now reset to the neutral.

Home safe and approach lighting

The light* on the door mirrors illuminates when the approach lighting or home safe lighting is activated.

**Windows, rearview and door mirrors****Blind Spot Information System, BLIS***

BLIS is an information system that under certain conditions can help to draw the driver's attention to vehicles moving in the same direction in the so-called "blind spot", see page 171.

Power sunroof*

Open positions

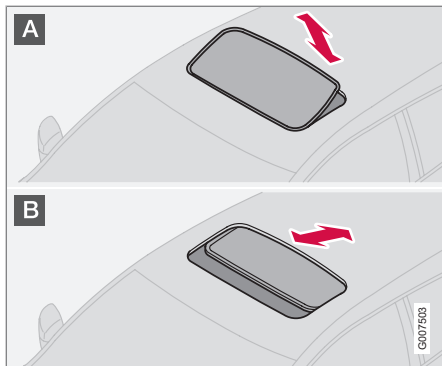

The sunroof controls are located in the roof panel. The sunroof can be opened in two positions:

- A** Ventilation position, up at the rear edge
- B** Sliding position, backwards/forwards

The remote control key must be in position **I** or **II**.

WARNING

If there are children in the car:

Switch off the supply to the power sunroof by removing the remote control key if the driver leaves the car.

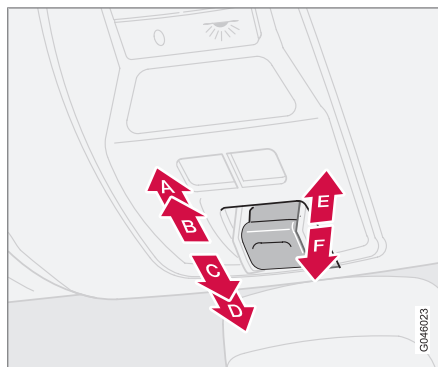

- A** Opening, automatic
- B** Opening, manual
- C** Closing, manual
- D** Closing, automatic
- E** Opening, ventilation position
- F** Closing, ventilation position

Ventilation position

Open:

- Press the rear edge of the control (E) upward.

Close:

- Pull the rear edge of the control (F) downward.

From ventilation position to fully open sunroof:

- Pull the control rearward to the end position (A) and release.

Sliding position

Automatic operation

- Pull the control past the point of resistance (B) to the rear end position (A) or past the point of resistance (C) to the forward end position (D) and release. The sunroof opens/closes completely.

Manual operation

Open:

- Pull the control rearward to the point of resistance (B). The sunroof moves to maximum open position as long as the button is kept depressed.

Close:

- Press the control forward to the point of resistance (C). The sunroof moves to



Power sunroof*

closed position as long as the button is kept depressed.

WARNING

The sunroof's pinch-protection function only operates during automatic closing, not manual closing.

Closing with remote control or lock button

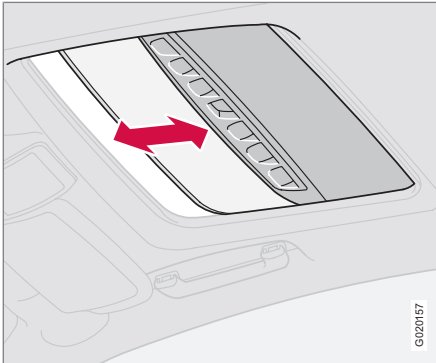

- One long press on the lock button closes the sunroof and all the windows. The doors and the tailgate are locked.

If you need to interrupt closing:

- Press the lock button again.

WARNING

Make sure that children or other passengers are not in danger of becoming trapped in any way when closing the sunroof with the remote control. Always operate the sunroof with caution.

Sunscreen

The sunroof features a manual, sliding interior sunscreen. The sunscreen slides back automatically when the sunroof is opened. Grip the handle and slide the screen forward to close it.

Pinch protection

The sunroof's pinch protection function is activated if the hatch is blocked by an object. If blocked, the sunroof will stop and automatically open to the previous position.

WARNING

The sunroof's pinch protection function only operates during automatic closing, not during manual closing.

Make sure that nobody is in danger of becoming trapped in any way when closing the sunroof.

Wind deflector

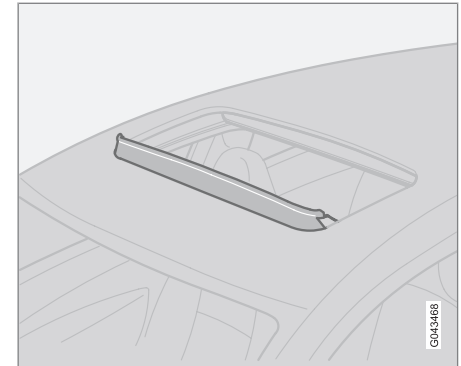

The sunroof has a wind deflector that is folded up when the sunroof is in the open position.



Personal preferences

Possible settings

Personal preferences can be set for some of the car's functions. This applies to locks, climate control and audio functions. For audio functions, see page 252.

Control panel

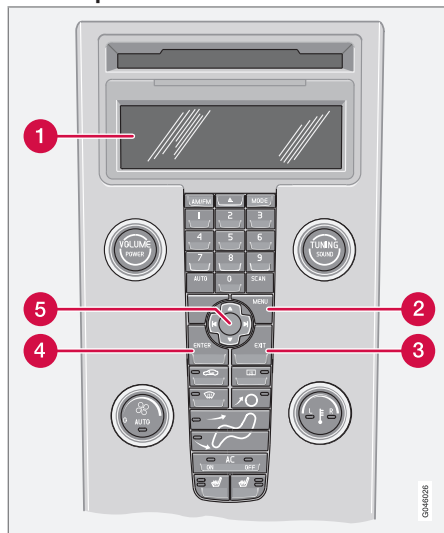

Control panel.

- 1 Display
- 2 **MENU**
- 3 **EXIT**
- 4 **ENTER**
- 5 Navigation

Use

The settings are shown on the display (1).

Open the menu to enter settings:

1. Press **MENU** (2).
2. Scroll, for example, to **Car settings...** with the navigation button (5).
3. Press **ENTER** (4).
4. Select an alternative with the navigation button (5).
5. Press **ENTER** to activate the selection.

Activated function is shown in the display with . Deactivated function is shown in the display with .

Close the menu:

- Press **EXIT** (3) for approx. one second.

Clock, adjustment

The hour and minute are each adjusted separately.

1. Use the numbers on the keypad or "arrow up" or "arrow down" on the navigation button (5).
2. Select the number for adjustment using "arrow right" or "arrow left" on the navigation button.
3. Press **ENTER** to start the clock.

NOTE

If the car has a 12-hour clock then **AM/PM** is selected using "arrow up" or "arrow down" after the final minute number has been adjusted.

Climate settings

Automatic blower adjust

The fan speed can be set to **AUTO** mode in cars equipped with ECC:

- Select from **Low**, **Normal** and **High**.

Recirculation timer

When the timer is active, the air recirculates for 3-12 minutes, depending on the outside air temperature.



Personal preferences

- Select On/Off depending on whether or not you wish the recirculation timer to be active.

Reset all

Resets the climate function options to the factory settings.

Car settings

Retract mirrors when locking*

When the car is locked/unlocked with the remote control the door mirrors can be retracted/extended automatically. The On/Off option is available.

Reduced guard*

The deadlocks function can be temporarily deactivated and the alarm level reduced if someone wishes to remain in the car and the doors have to be locked from the outside. The **Activate once** and **Ask on exit** options are available, see pages 133 and 136.

Unlock confirm. light

The hazard warning flashers can provide feedback when the car is unlocked with the remote control. The On/Off option is available.

Lock confirm. light

The hazard warning flashers can provide feedback when the car is locked with the remote control. The On/Off option is available.

Doors – auto lock

When the speed of the car exceeds 7 km/h the doors and tailgate can be locked automatically. The On/Off option is available.

Doors unlock

There are two alternatives for unlocking:

- **All doors** – one press of the remote control unlocks both doors and the tailgate.
- **Driver door, then all** – one press of the remote control unlocks the driver's door. A second press then unlocks the passenger door and the tailgate.

Keyless entry

- **All doors** – both doors and the tailgate are unlocked simultaneously¹.
- **Any door** – any door or the tailgate can be unlocked separately.

Simultaneous closing/opening of all windows

This function can be selected for the lock button on the remote control and the front doors' central locking button, as well as the outside

door handle button on cars with the keyless system:

- **Auto. close all windows** – all windows and the sunroof are closed simultaneously with one long press on the lock button.

This function can be selected for the unlock button on the remote control and the front doors' central locking button:

- **Auto. open all windows** – all windows are opened simultaneously with one long press on the unlock button.

Approach lighting

Select the time the car's lights should remain switched on when the approach lighting button is pressed - see page 124.

The following alternatives are available:

- **30 seconds**
- **60 seconds**
- **90 seconds**

Home safe lighting

Select the time the car's lights should remain on when the left-hand stalk switch is pulled back after the remote control key has been removed - see page 61.

The following alternatives are available:

¹ Both doors and the tailgate can also be locked simultaneously.



Personal preferences

- 30 seconds
- 60 seconds
- 90 seconds

Information

- **VIN number...** - (Vehicle Identification Number) is the car's unique identity number.
- **Number of keys...** - The number of keys registered for the car is shown.



General

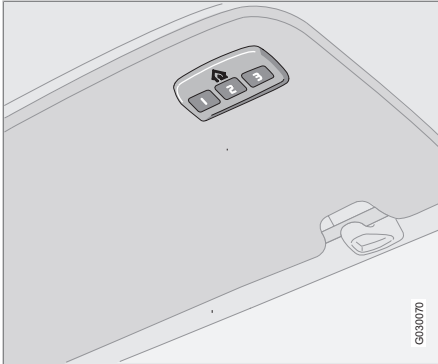

HomeLink®¹ is a programmable remote control which can remotely control up to three different devices (e.g. garage door opener, alarm system, outdoor lighting and indoor lighting etc.) and in doing so replace their remote controls. For more information on HomeLink®, visit: www.homelink.com or ring 00 8000 466 354 65 (or premium rate phone number, +49 6838 907 277).

WARNING

- If HomeLink® is used to operate a garage door or gate, make sure that there is no-one in the vicinity of the door or gate while it is moving.
- The car should remain outside the garage while a garage door opener is being programmed.
- Do not use HomeLink® for any garage door that does not have safety stop and safety reverse.

Save the original remote controls for future programming (e.g. when changing to another car or for use in another vehicle). It is also recommended that the programming for the buttons is deleted when the car is sold. See the section "Resetting the HomeLink® buttons" on page 84.

Programming HomeLink®

NOTE

In certain vehicles the ignition must be switched on or in "accessory position" before HomeLink® can be programmed or used. If possible, fit new batteries in the remote control that shall be replaced by HomeLink® for faster programming and improved transmission of the radio signal. The HomeLink® buttons should be reset before programming. When this has been done HomeLink® is set in "learn mode" and ready for programming.

1. Aim the original remote control towards the HomeLink® button to be programmed and hold it 5-14 cm from the button. Do not obstruct the indicator lamp on HomeLink®.
2. Depress the button on the original remote control and the button to be programmed on HomeLink® simultaneously. Do not release the buttons until the indicator lamp has changed over from slow to rapid flashing. Both the buttons must be released when the indicator lamp flashes quickly.

¹ HomeLink and the HomeLink house symbol are registered trademarks of Johnson Controls, Inc.



HomeLink® *

3. **Depress the HomeLink® button being programmed, hold it depressed for 5 seconds and then release it.** Repeat if necessary until the garage door is activated. If the door is not activated, press the programmed HomeLink® button and hold it depressed and check the indicator lamp.

> **Constant glow:** The indicator lamp illuminates with a constant glow when the button is kept depressed, this indicates that the **programming is complete.**

The garage door, gate or similar should now be activated when the programmed HomeLink® button is depressed.

Glow not constant: The indicator lamp flashes quickly for approx. 2 seconds and then changes over to a constant glow. In which case, continue with the programming steps 4-6 in order to complete the programming of a device with rolling code (usually a garage door opener).

4. Locate the "programming button²" on the receiver for the garage door for example, normally located close to the antenna's bracket on the receiver.

5. Depress and release the receiver's "programming button". The button flashes for approx. 30 seconds and the next step must be carried out within this period.
6. While the receiver's "programming button" is still flashing, press the button on HomeLink® being programmed and hold it depressed for approx. 2 seconds and then release it. Repeat the press/hold/release sequence up to 3 times to conclude the programming.

Operation

When HomeLink® is fully programmed it can be used in place of the separate original remote controls.

Press the programmed button and hold it depressed until the garage door, alarm system, etc. is activated (may take several seconds). Naturally the original remote controls can still be used in parallel with HomeLink® if required.

NOTE

If the ignition is switched off, HomeLink® will work for 30 minutes after the driver's door has been opened.

If programming problems persist, contact HomeLink® on: www.homelink.com or ring 00 8000 466 354 65 (or premium rate phone number +49 6838 907 277).

Resetting the HomeLink® buttons

It is only possible to reset all of the HomeLink® buttons at the same time, not each button individually. However, individual buttons can be reprogrammed, see the following section "Programming individual buttons".

1. Depress the two outer buttons on HomeLink® and do not release until the indicator lamp starts to flash.
2. Release the buttons.
 - > HomeLink® is now set in so-called "learn mode" and is ready to be reprogrammed, see section "Programming HomeLink®" on page 83.

² Button designation and colour vary depending on manufacturer.

* Option/accessory, for more information, see Introduction.



Programming individual buttons

To reprogram an individual HomeLink® button, proceed as follows:

1. Depress the required button and **do not release**.
2. When the indicator lamp on HomeLink® starts to flash, after approx. 20 seconds, start with step 1 in section "Programming HomeLink®" on page 83.

For more information or to leave comments about HomeLink®, visit: www.homelink.com or ring 00 8000 466 354 65 (or premium rate phone number +49 6838 907 277).

General information on climate control.....	88
Manual climate control, AC.....	90
Electronic climate control, ECC*.....	93
Air distribution.....	96
Fuel-driven engine block heater and passenger compartment heater*..	97
Fuel-driven auxiliary heater* (diesel).....	100



03

CLIMATE CONTROL





General information on climate control

Air conditioning

The climate control system cools or heats as well as dehumidifies the air in the passenger compartment. The car is equipped with either manual (AC) or electronic climate control (ECC, Electronic Climate Control).

i NOTE

The air conditioning system can be switched off, but to ensure the best possible air in the passenger compartment and prevent the windows from misting, it should always be on.

Misting windows

Remove misting on the insides of the windows by first using the defroster function.

To reduce the risk of misting, clean the windows with a normal window cleaning agent.

Ice and snow

Remove ice and snow from the climate control air intake (the grille between the bonnet and the windscreen).

Passenger compartment filter

All air entering the car's passenger compartment is only cleaned with one filter. This must be replaced at regular intervals. Follow the Volvo Service Programme for the recommended replacement intervals. If the car is used in a severely contaminated environment, it may be necessary to replace the filter more often.

i NOTE

There are different types of passenger compartment filter. Make sure that the correct filter is fitted.

Display

There is a display above the climate control panel. This displays climate control settings.

Personal preferences

You can set preferences for two climate control functions:

- Fan speed in **AUTO** mode (applies only to cars with ECC).
- Recirculation timer for passenger compartment air.

For information about these settings, see page 80.

Air vents in the instrument panel

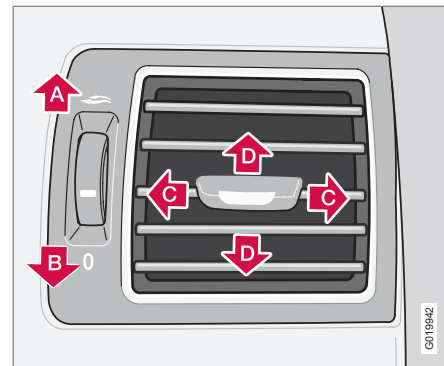

- A** Open
- B** Closed
- C** Lateral airflow
- D** Vertical airflow

Aim the outer vents towards the side windows to remove misting from the front side windows.

During cold weather - Close the centre vents for optimum comfort and best demisting.



General information on climate control

ECC*

Actual temperature

The temperature you select corresponds to the physical experience with reference to factors such as air speed, humidity and solar radiation in and around the car.

The system includes a sun sensor which detects the side from which the sun is shining into the passenger compartment. This means that the temperature can differ between the right and left-hand air vents despite the controls being set for the same temperature on both sides.

Sensor location

- The sun sensor is on the top side of the instrument panel.
- The temperature sensor for the passenger compartment is behind the climate control panel.
- The outside temperature sensor is located on the door mirror.
- The humidity sensor is located in the interior rearview mirror.

NOTE

Do not cover or block the sensors with clothing or other objects.

Side windows and sunroof

To ensure that the air conditioning works satisfactorily, close all side windows and the sunroof (if fitted).

Acceleration

The air conditioning system switches off temporarily at full throttle. You may briefly feel a temporary rise in temperature.

Condensation

In warm weather, condensation from the air conditioning may drip under the car. This is normal.



Manual climate control, AC

Control panel

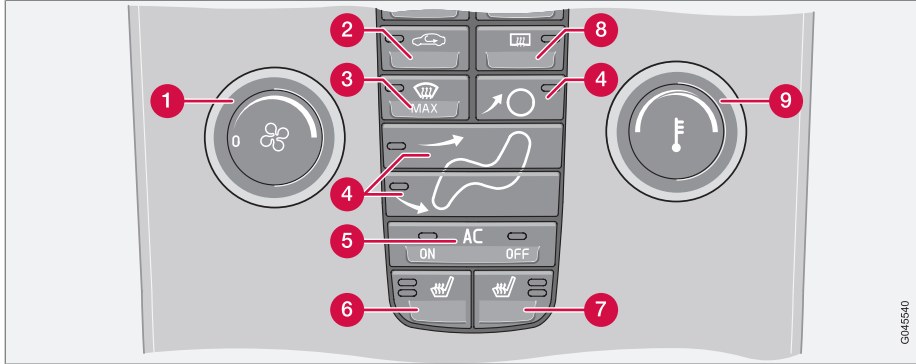

- 1 Fan
- 2 Recirculation
- 3 Defroster
- 4 Air distribution
- 5 **AC ON/OFF** – Air conditioning On/Off
- 6 Heated front left seat
- 7 Heated front right seat
- 8 Rear window and door mirror defrosters
- 9 Temperature

Functions

1. Fan

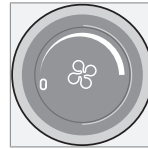

Increase or decrease the fan speed by turning the knob.

If the knob is turned anticlockwise and the fan indicator in the display goes out, the fan and the air conditioning are switched off. The display shows the fan symbol and **OFF**.

2. Recirculation

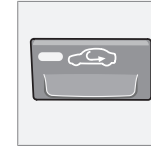

Recirculation can be used to shut out bad air, exhaust fumes, etc. from the passenger compartment. The air in the passenger compartment is recirculated. No outside air is taken into the car. Recirculation (together with the air conditioning system) cools the passenger compartment more quickly in a warm climate. If the air in the car recirculates for too long, there is a risk of misting on the insides of the windows.

GM4540



Manual climate control, AC

Timer

The timer function reduces the risk of icing, misting and bad air (if recirculation is selected). See page 80 for activating/deactivating the function. When the Defroster (3) program is selected, recirculation is deactivated.

3. Defroster



Used to quickly remove misting and ice from the windscreen and side windows. Air flows to the windows at high fan speed. The light in the defroster button illuminates when the function is active.

The following also takes place when the defroster function is activated in order to provide maximum dehumidification in the passenger compartment:

- the air conditioning (AC) is automatically switched on (can be switched off with the **AC** button (5))
- recirculation is automatically disengaged.

When the defroster is switched off the climate control returns to the previous settings.

4. Air distribution



The airflow can be distributed to the windows, dashboard vents or floor by pressing the air distribution buttons.

A symbol on the display above the climate control

panel and an illuminated light in the relevant button indicate which function has been selected.

Refer to the table on page 96.

5. AC – On/Off (ON/OFF)

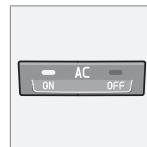

ON: The air conditioning is on. It is controlled by the system's AUTO function. This way, incoming air is cooled and dehumidified.

OFF: The air conditioning is

off.

When the defroster function is activated the air conditioning is automatically switched on (can be switched off with the **AC** button). An illuminated lamp above the button shows the function selected.

6. and 7. Heated front seats*



Higher heat:

- Press the button once – both lights illuminate.

Lower heat:

- Press the button once – one light illuminates.

Heat off:

- Press the button three times – light not illuminated.

8. Rear window and door mirror defrosters



Heating is used to quickly remove misting and ice from the rear window and door mirrors. Press the button once to start simultaneous rear window and rearview mirror defrosting. The function is

active if one lamp is illuminated in the button.

The function is switched off manually or automatically. Switch off manually with one press



Manual climate control, AC

on the button. Automatic switching off disconnects the rear window and door mirrors after 12 – 20 minutes depending on outside temperature.

During cold weather the defrosting* also continues after 20 minutes in order to keep the rear window and door mirrors free of ice and mist. The intensity of the defrosting can be adapted to the outside temperature. This function must be switched off manually.

9. Temperature



Select cooling or heating for both driver and passenger side.



Electronic climate control, ECC*

Control panel

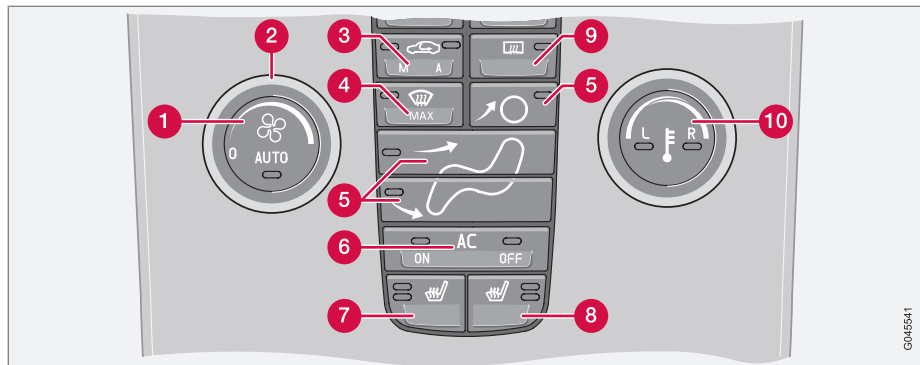

- 1 **AUTO**
- 2 Fan
- 3 Recirculation/Air quality system
- 4 Defroster
- 5 Air distribution
- 6 **AC ON/OFF** – Air conditioning On/Off
- 7 Heated front left seat
- 8 Heated front right seat
- 9 Rear window and door mirror defrosters
- 10 Temperature selector

Functions

1. AUTO

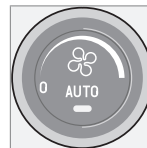

The **AUTO** function automatically regulates climate control and maintains the selected temperature. The AUTO function controls heating, air conditioning, fan speed, recirculation, and air

distribution.

If you select one or more manual functions, the other functions continue to be controlled automatically. All manual settings are switched off when **AUTO** is switched on. The display shows **AUTO CLIMATE**.

2. Fan

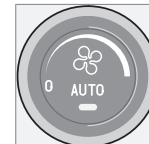

Turn the knob to increase or decrease fan speed. If **AUTO** is selected then fan speed is regulated automatically. The previously set fan speed is disengaged.

i NOTE

If the knob is turned anticlockwise and the fan indicator in the display goes out, the fan and the air conditioning are switched off. The display shows the fan symbol and **OFF**.



Electronic climate control, ECC*

3. Recirculation



The function is selected to shut out bad air, exhaust gases etc. from the passenger compartment. The air in the passenger compartment is recirculated, i.e. no outside air is taken into the car when

this function is activated. If the air in the car recirculates for too long, there is a risk of misting on the insides of the windows.

Timer

The timer function reduces the risk of icing, misting and bad air (if recirculation is selected). To activate/deactivate the function see page 80.

NOTE

When Defroster (4) is selected, recirculation is always deactivated.

3. Air quality system*



Same button as recirculation.

The air quality system consists of a multi-filter and a sensor. The filter separates gases and particles to reduce the levels of odours and pollution in the passenger compartment. When the sensor detects polluted outside air, the air intakes are closed and the air in the passenger compartment is recirculated. A green light (A) illuminates in the button when the air quality sensor is active.

Activating the air quality sensor:

- Press **AUTO** (1) to activate the air quality sensor (normal setting).

Or:

- Switch between three functions by pressing repeatedly the recirculation button.
- Air quality sensor engaged – the light (A) illuminates.
- No recirculation engaged, provided it is not required for cooling in hot weather – light not illuminated.
- Recirculation engaged – the light (M) illuminates.

Keep the following in mind:

- As a rule, the air quality sensor should always be engaged.
- Recirculation is limited in cold weather to avoid misting.

- The defroster functions for the front, side and rear windows can be used to demist the windows.

4. Defroster



Used to quickly remove misting and ice from the wind-screen and side windows. Air flows to the windows at high fan speed. The light in the defroster button illuminates when the function is active.

The following also takes place when the defroster function is activated in order to provide maximum dehumidification in the passenger compartment:

- the air conditioning (AC) is automatically switched on (can be switched off with the **AC** button (6))
- recirculation is automatically disengaged.

When the defroster is switched off the climate control returns to the previous settings.

5. Air distribution

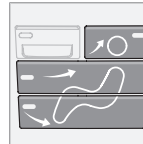

The airflow can be distributed to the windows, dashboard vents or floor by pressing the air distribution buttons.



Electronic climate control, ECC*

A symbol on the display above the climate control panel and an illuminated light in the relevant button indicate which function has been selected.

Refer to the table on page 96.

6. AC – On/Off (ON/OFF)

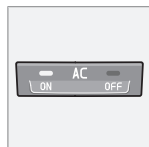

ON: The air conditioning is on. It is controlled by the system's AUTO function. This way, incoming air is cooled and dehumidified.

OFF: Off

When the defroster function is activated the air conditioning is automatically switched on (can be switched off with the **AC** button).

i NOTE

The climate control system's demisting function with humidity sensor is significantly reduced with the air conditioning in deactivated mode (**OFF**), as well as with manually selected air distribution and fan speed.

7 and 8. Heated front seats*



To activate front seat heating:

Higher heat:

- Press the button once – both lights illuminate.

Lower heat:

- Press the button once – one light illuminates.

Heat off:

- Press the button three times – light not illuminated.

9. Rear window and door mirror defrosters



Heating is used to quickly remove misting and ice from the rear window and door mirrors. Press the button once to start simultaneous rear window and rearview mirror defrosting. The function is

active if one lamp is illuminated in the button.

The function is switched off manually or automatically. Switch off manually with one press

on the button. Automatic switching off disconnects the rear window and door mirrors after 12 – 20 minutes depending on outside temperature.

During cold weather the defrosting* also continues after 20 minutes in order to keep the rear window and door mirrors free of ice and mist. The intensity of the defrosting can be adapted to the outside temperature. This function must be switched off manually.

10. Temperature selector



The temperatures on the driver and passenger sides can be set independently.

Press the button once to activate one side only. Press again to activate the other side. Press the button a third time to activate both sides.

The active side is indicated by the button's light and in the display above the climate control panel.

When the car is started, the most recent setting is resumed.

i NOTE









Heating or cooling cannot be hastened by selecting a higher or lower temperature than the actual desired temperature.



03 Climate control

Air distribution

03

	Air distribution	Use:		Air distribution	Use:
	Air to windows. Some air flows from the air vents. The air is not recirculated. Air conditioning is always engaged.	to remove ice and misting quickly.		Air to the floor and windows. Some air flows from the dashboard air vents.	to ensure comfortable conditions and good demisting in cold or humid weather.
	Air to windscreen and side windows. Some air flows from the air vents.	to prevent misting and icing in a cold and humid climate. (Not for low fan speed.)		Air to floor and from dashboard air vents.	in sunny weather with cool outside temperatures.
	Airflow to windows and from dashboard air vents.	to ensure good comfort in warm, dry weather.		Air to floor. Some air flows to the dashboard air vents and windows.	to warm the feet.
	Airflow to the head and chest from the dashboard air vents.	to ensure efficient cooling in warm weather.		Airflow to windows, from dashboard air vents and to the floor.	to provide cooler air for the feet or warmer air to the upper body in cold weather or hot, dry weather.



Fuel-driven engine block heater and passenger compartment heater*

General information about heaters

The parking heater heats the engine and passenger compartment and can be started directly or with the timer.

Two different times can be selected using the timer. Here, time refers to the time when the car is heated and ready. The car's electronic system calculates when heating should be started based on the outside temperature.

At -10 °C or lower the maximum running time of the parking heater is 50 minutes.

WARNING

The car must be outdoors when the petrol or diesel heater is used.

NOTE

When the parking heater is active there may be smoke from underneath the car, which is perfectly normal.

Refuelling

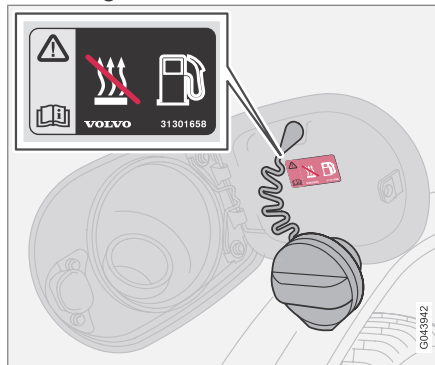

Warning decal on fuel filler flap.

WARNING

Fuel which spills out could be ignited. Switch off the fuel-driven heater before starting to refuel.

Check on the information display that the parking heater is switched off. When it is running, the information display shows **PARK HEAT ON**.

Parking on a hill

If the car is parked on a steep hill, the front of the car should point downhill to ensure that there is a supply of fuel to the parking heater.

Battery and fuel

If the battery has insufficient charge or the fuel level is too low, the parking heater is switched off automatically and a message appears on the information display.

- Acknowledge the message by pressing the indicator stalk **READ** button once.

IMPORTANT

Repeated use of the parking heater combined with short journeys may discharge the battery and impair starting.

The car should be driven for the same time as the heater is used to ensure that the car's battery is recharged adequately to replace the energy consumed by the heater when it is used on a regular basis.



Fuel-driven engine block heater and passenger compartment heater*

Activating the heater

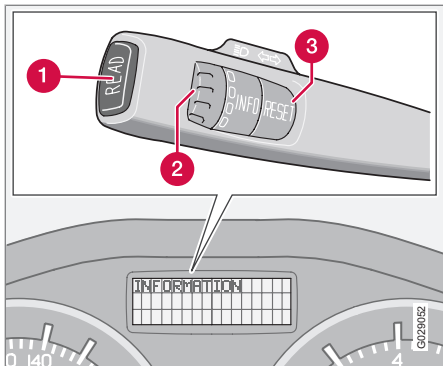

- 1 **READ** button
- 2 Thumbwheel¹
- 3 **RESET** button¹

Symbols and display messages



When one of the timer's settings or **Direct start** is activated, the information symbol in the combined instrument panel illuminates and the information display shows an explanatory text.

Display	Specification
FUEL HEATER ON	The heater is switched on and running.
TIMER IS SET FOR FUEL HEATER	Reminder that the heater will start at the set time after the car has been left, when the remote control key is removed from the ignition switch.

Display	Specification
HEATER STOPPED LOW BATTERY	The heater has been stopped by the car's electronics in order to facilitate starting the engine.
HEATER STOPPED LOW FUEL LEVEL	The heater has been stopped by the car's electronics in order to facilitate starting the engine as well as 50 km driving.

Direct start and immediate stop

1. Scroll with the thumbwheel to **DIRECT START PARK HEAT OFF** or **DIRECT START PARK HEAT ON**.
2. Long presses on the **RESET** button change between the two alternatives.

DIRECT START PARK HEAT ON: Parking heater switched on manually or with programmed timer.

DIRECT START PARK HEAT OFF: Parking heater switched off.

¹ No function in cars without trip computer, fuel-driven parking heater as well as stability and traction control system.

* Option/accessory, for more information, see Introduction.



Fuel-driven engine block heater and passenger compartment heater*

With the direct start of the heater it will be activated for 50 minutes.

Heating of the passenger compartment will begin as soon as the engine coolant has reached the correct temperature.

NOTE

The car can be started and driven while the parking heater is running.

Setting the timer

The time when the car shall be used and heated is specified with the timer.

Select between **TIMER 1** and **TIMER 2**.

1. Scroll with the thumbwheel to **PARK HEAT TIMER --:-- ON**.
2. Give a long press (approx. 2 seconds) on the **RESET** button in order to access the flashing time setting.
3. Select the required hour using the thumbwheel.
4. Briefly press **RESET** to move to the flashing minutes setting.
5. Select the required minute using the thumbwheel.
6. Briefly press **RESET** to confirm the setting.

7. Press **RESET** to activate the timer.

After setting **TIMER 1** a second start time can be programmed with **TIMER 2** by scrolling with the thumbwheel.

Set the alternative time in the same way as **TIMER 1**.

Deactivating a timer-started heater

A timer-started heater can be switched off manually before the set time has elapsed. Proceed as follows:

1. Press the **READ** button.
2. Use the thumbwheel to scroll to the text **PARK HEAT TIMER 1** or **PARK HEAT TIMER 2**.

The text **ON** flashes on the display.

3. Press **RESET**.

The text **OFF** is shown with a constant glow and the heater is switched OFF.

A timer-started heater can be switched off in accordance with the instructions in the section "Direct start and immediate stop".

Clock/timer

The heater's time is connected to the car's clock.

NOTE

All timer programming will be cleared if the car's clock is reset.



Fuel-driven auxiliary heater* (diesel)

Auxiliary heater (diesel)

In diesel-engined cars the auxiliary heater may be required for achieving the correct temperature in the engine and passenger compartment during cold weather.

The heater starts automatically when extra heat is required when the engine is running.

The heater is switched off automatically when the correct temperature is reached or when the engine is switched off.



NOTE

The auxiliary heater cannot be switched on or off manually but is only controlled by the car's electronics.

When the auxiliary heater is active there may be smoke from underneath the car, which is perfectly normal.



Front seats.....	104
Interior lighting.....	109
Storage spaces in the passenger compartment.....	112
Rear seat.....	116
Cargo area.....	118



04

INTERIOR





Front seats

Seating position, manual seat



The driver's and passenger seats can be adjusted to the optimum sitting and driving positions.

- 1 Forward/backward: lift the handle to adjust the distance to the steering wheel and pedals. Check that the seat is locked after changing the position setting.
- 2 Raise/lower the front of the seat cushion (driver's and passenger seat*), pump up/down.
- 3 Raise/lower the seat, pump up/down.
- 4 Lumbar support¹, turn the wheel.

¹ Also applies to power seat.

5 Backrest rake: turn the wheel.

6 Control panel for power seat*.

Lever (2) is not available on all seat models.

WARNING

Adjust the position of the driver's seat and adjust the seatbelt, see page 16, before setting off, never while driving.

Check that the seat is locked in position.

NOTE

When putting on the seatbelt it is easiest to pick it up from down at the seatbelt guide, not over the shoulder.

Seating position, power seat*

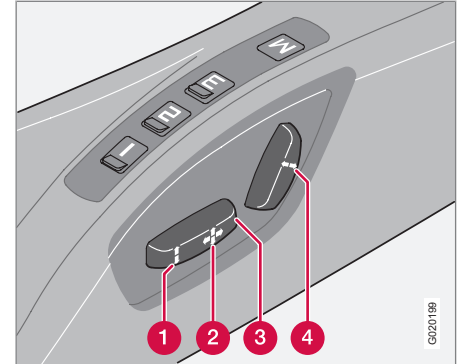

The seats can be adjusted for a certain time after unlocking the door with the remote control key without the key being inserted into the ignition switch. The seat can always be adjusted in key position I or II.

- 1 Front edge of seat cushion up/down
- 2 Seat, forwards/backwards
- 3 Seat, up/down
- 4 Backrest rake



Front seats

An overload protection is deployed if one of the seats is blocked. If this happens, turn off the ignition and wait a short time before adjusting the seat again. Only one of the seat's settings can be adjusted at a time.

Memory function

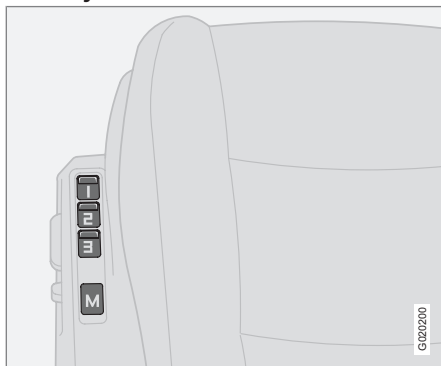

Buttons for memory function.

Store setting

1. Adjust seat.
2. Press and hold button **M** while pressing button **1**, **2** or **3** simultaneously.

Using a stored setting

Press one of the memory buttons **1–3** until the seat stops. If you release the button then the movement of the seat will stop.

Emergency stop

If the seat accidentally begins to move, press one of the setting buttons for the seat or memory buttons in order to stop the seat.

WARNING

Risk of crushing. Make sure that children do not play with the controls.

Check that there are no objects in front of, behind or under the seat during adjustment.

Ensure that none of the rear seat passengers is in danger of becoming trapped.

Memory in remote control key

All remote control keys can be used by different drivers to store the settings for the driver's seat². Proceed as follows:

- Adjust the seat as you want it.
- Lock the car by pressing the lock button on the remote control key that you normally use. This stores the positions of the seat in the remote control key's memory³.

- Unlock the car (by pressing the unlock button on the **same** remote control key) and open the driver's door. The driver's seat will automatically adopt the position that is stored in the remote control key's memory (if the seat has been moved since you locked the car).

Entry to the rear seat

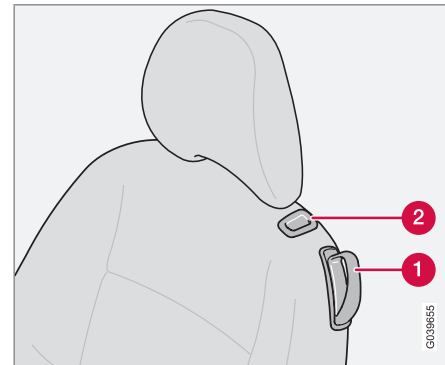

- 1 Handle for lowering the backrest
- 2 Button for moving the power seat longitudinally

² Only if the car is equipped with power seat with memory.

³ This setting does not affect settings that have been stored in the power seat's memory function.



Front seats

i NOTE

No one may sit in the seat when it is pushed forward for entry into the rear seat.

i NOTE

Lower the seat before it is pushed forward - otherwise there is a risk that the head restraint makes contact with the sun visor.

Manual seat

Push the seat forward:

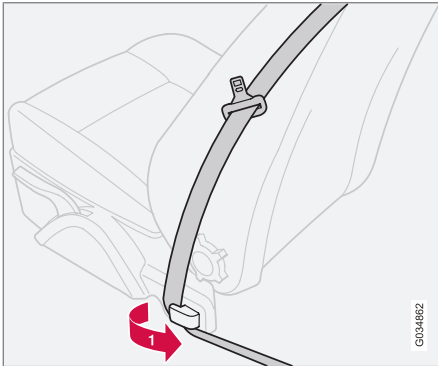

- 1** Release the seatbelt from the seatbelt guide, see also page 18.

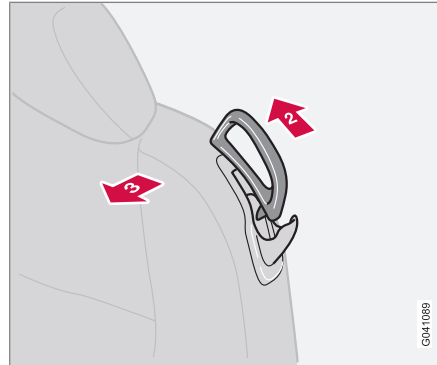

- 2** Lift the handle.
- 3** Fold the backrest forward and slide the seat forward.

Push the seat backward:

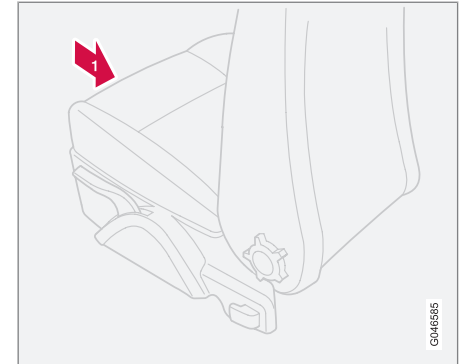

- 1** Push the seat backward.
- 2. Adjust the seat longitudinally.
- 3. Fold the backrest back up.
- 4. Refit the seatbelt in the seatbelt guide.

If the seat has not returned to the same position, as before it was folded for entry, after having been pushed back - then proceed as follows:

- 1. Sit down in the seat.
- 2. Lift the handle (1), see page 104, and push the seat to the rear end position.



Front seats

3. Continue to lift of the handle, and push the seat forward to the desired position and release the handle.

Power seat*

Push the seat forward:

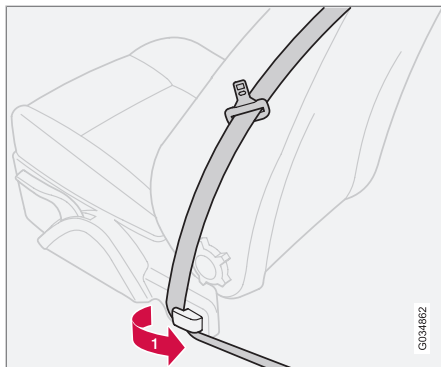

- 1) Release the seatbelt from the seatbelt guide, see also page 18.



- 2) Lift the handle.
3) Fold the backrest forward to the locked position.



- 4) Hold down the front section of the button.

If the seat is set in a higher position - then it will be lowered automatically to avoid the head restraint making contact with the sun visor.



Front seats

Push the seat backward:

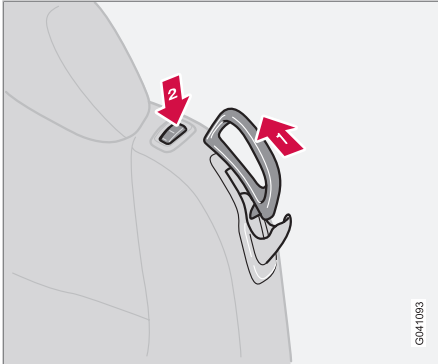

- 1 Lift the handle and fold back the backrest.
- 2 Hold down the rear section of the button.
- 3 Refit the seatbelt in the seatbelt guide.

NOTE

The seat can only be moved to the very front (+6 cm) to facilitate entry and exit to and from the rear seat when the backrest has been folded forward. If the backrest is folded back when the seat is in the front position then the seat automatically moves back approx. 6 cm after a few seconds.

WARNING

Check that the backrest is properly folded back by pushing and pulling the head restraint.

The belt on the front passenger side must be in the belt guide during driving, even when there is no passenger sitting in the seat.

Inlaid mats*

Volvo supplies inlay mats which are especially produced for your car.

WARNING

Before setting off check that the inlaid mat in the driver area is firmly affixed and secured in the pins in order to avoid getting caught adjacent to and under the pedals.



Interior lighting

Reading lamps and interior lighting

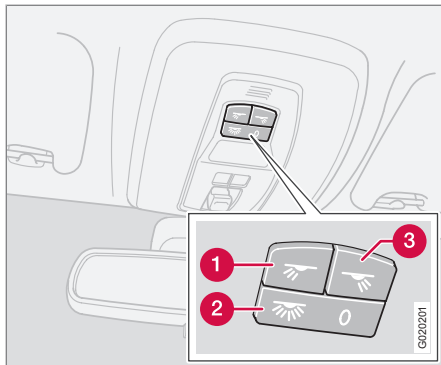

Controls in roof console for front reading lamps and passenger compartment lighting.

- 1 Reading lamp left-hand, On/Off
- 2 Interior lighting
- 3 Reading lamp right-hand, On/Off

All lighting in the passenger compartment can be switched on in key position **I** and **II** as well as when the engine is running. The lighting can also be activated within 30 minutes after:

- the engine has been switched off and the remote control key is in position **0**
- the car has been unlocked but the engine has not been started.

Roof lighting

The reading lamps are switched on or off by pressing the relevant button in the roof console.

Courtesy lighting

Courtesy lighting (and passenger compartment lighting) is switched on and off respectively when a side door is opened or closed.

Vanity mirror*

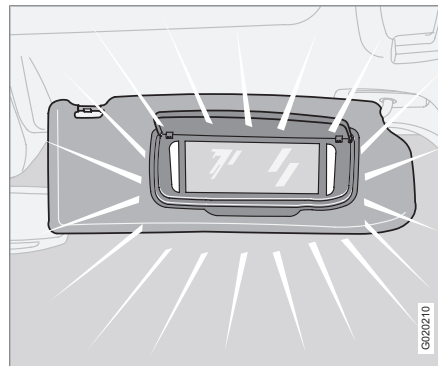

The lamp is automatically switched on and off respectively when the cover is opened or closed.

Glovebox lighting

Glovebox lighting is switched on and off respectively when the lid is opened or closed.

Cargo area lighting

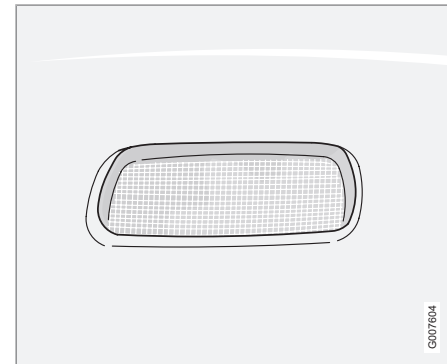

Passenger compartment lighting in rear seat and cargo area.

Apart from the passenger compartment lighting the cargo area has a further lamp on its left-hand side.

The lighting in the passenger compartment and cargo area is switched on and off respectively when the tailgate is opened or closed.



Interior lighting

Automatic lighting

Using the switch (2), see page 109, three positions can be selected for the lighting the passenger compartment:

- Off – right-hand side (marked with **0**) depressed, automatic lighting switched off.
- Neutral position – automatic lighting activated. The dimmer function is active.
- On – left-hand side depressed, passenger compartment lighting on.

Neutral position

When the switch (2) is in neutral position passenger compartment lighting is switched on and off automatically in accordance with the below.

The passenger compartment lighting is switched on and remains on for 30 seconds if:

- the car is unlocked with the remote control key or key blade.
- the engine is stopped and the remote control key is turned to position **0**.

Passenger compartment lighting is switched off when:

- the engine is started
- the car is locked with the key or remote control key.

Passenger compartment lighting comes on and remains on for 5 minutes if one of the doors is open.

If any lighting is switched on manually and the car is locked then it will be switched off automatically after 5 minutes.



Interior lighting



Storage spaces in the passenger compartment

Storage spaces

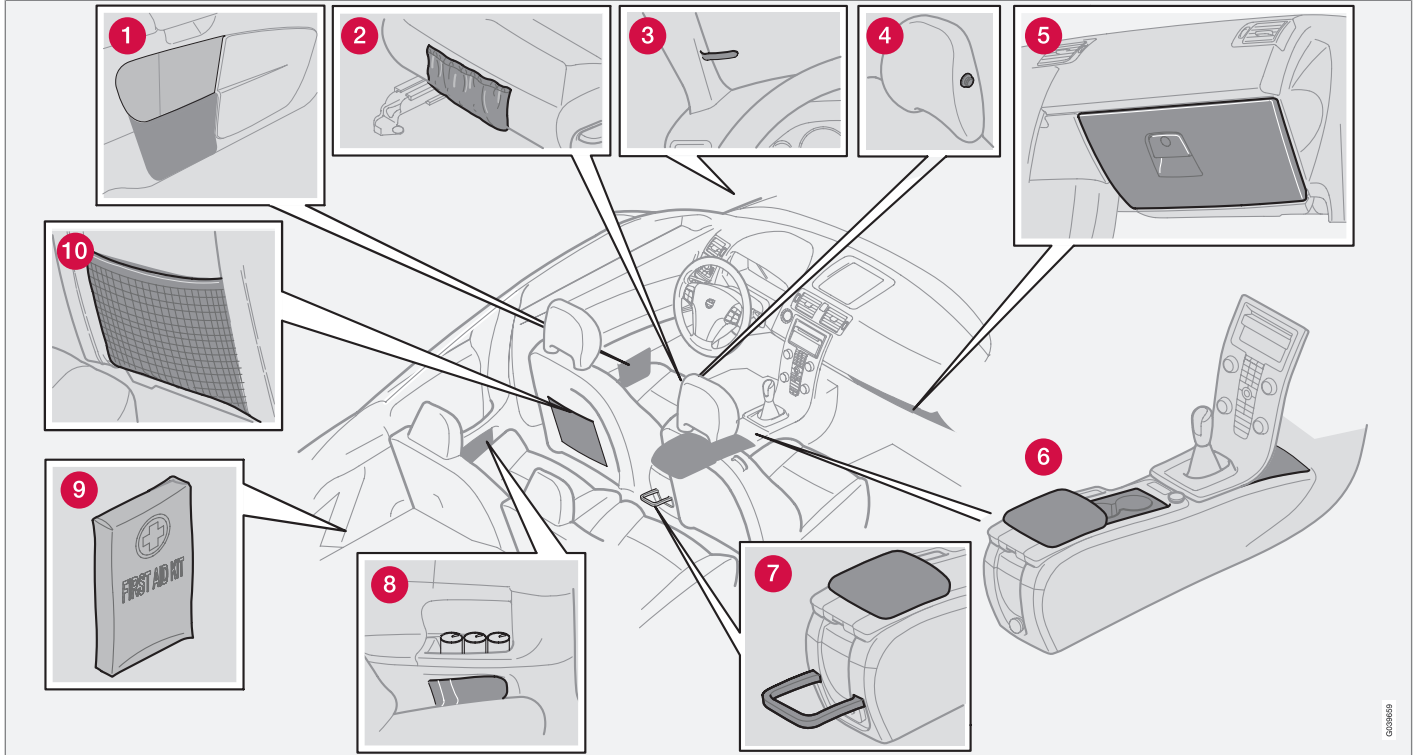

000569



Storage spaces in the passenger compartment

- 1 Storage compartment in door panel.
- 2 Storage pocket on front edge of front seat cushions (trim dependent).
- 3 Ticket clip
- 4 Coat hanger, only for light garments.
- 5 Glovebox
- 6 Storage compartment (e.g. for CD discs and cup holder,*) and storage compartment behind the centre console.
- 7 Bottle holder*
- 8 Storage compartments in rear side panels with space for up to three soda cans.
- 9 Storage compartment for first aid.
- 10 Storage pockets for maps and magazines.

WARNING

Ensure that no hard, sharp or heavy objects lie or protrude in such a way that they could cause injury during heavy braking.

Always secure large and heavy objects with a seatbelt or cargo retaining straps.

Glovebox

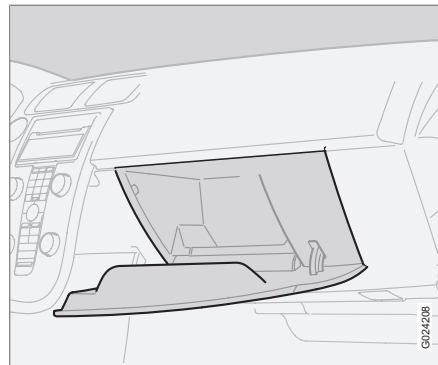

The owner's manual and maps can be kept here for example. There are also holders for coins, pens and fuel cards.

The glovebox can be locked with the remote control key's detachable key blade. Further information is available on page 125.

Coat hanger

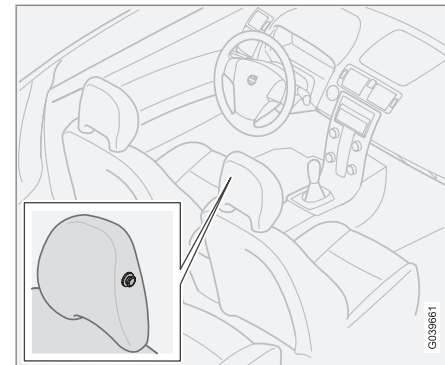

The coat hanger is located on the passenger seat head restraint. Only hang light garments on the hanger.



Storage spaces in the passenger compartment

Storage under the front armrest

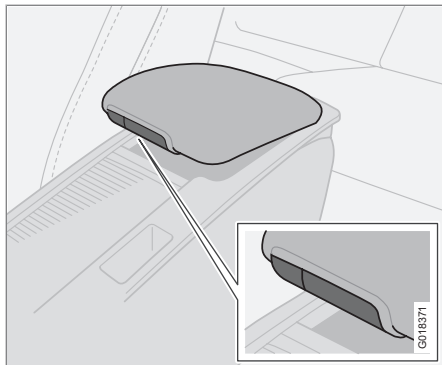

There is a storage space under the armrest. There is also a smaller storage space in the detachable armrest. Press the small button and lift the armrest to open the shallow compartment. Press the large button and lift the armrest to open the deeper compartment.

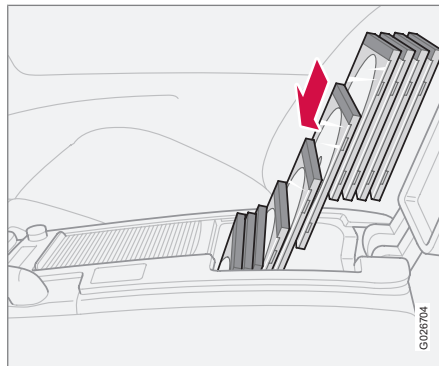

In the deeper compartment there is space for 10 normal CD cases. The cases must be stored vertically on the top edge for all 10 to have space.

Cup holder in centre console

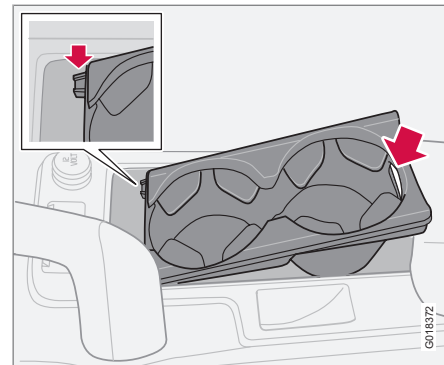

There is space for a double cup holder under the roller cover. The space can be used for storage by lifting out the cup holder. Lift at the rear edge of the cup holder where there is a recess.

If the cup holder is being fitted - first align its two guide lugs in the two recesses in the front edge of the space and then press down the rear edge of the cup holder.

Close the roller cover by gripping its front edge from below and pulling forward.



Storage spaces in the passenger compartment

Storage compartment behind the gear lever

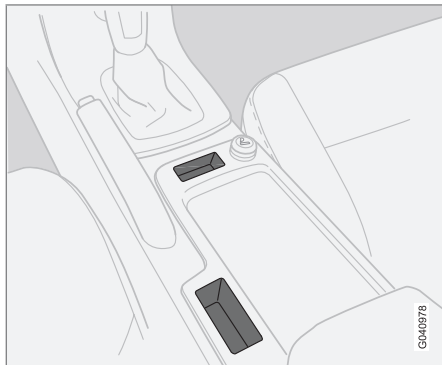

When there are no buttons for parking assistance and BLIS, see page 169 and page 171, the space can be used as a storage compartment.

WARNING

Objects placed in the storage compartments must not obstruct the parking brake lever when it is applied.

Bottle holder*

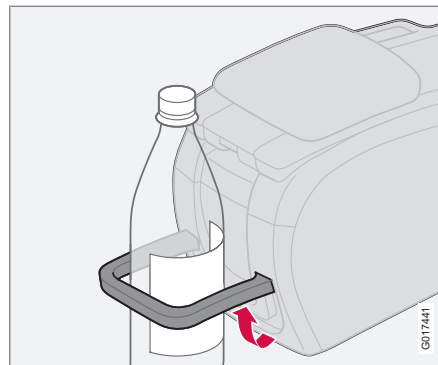

A bottle holder for larger bottles is located on the rear of the tunnel console.

Ashtray*

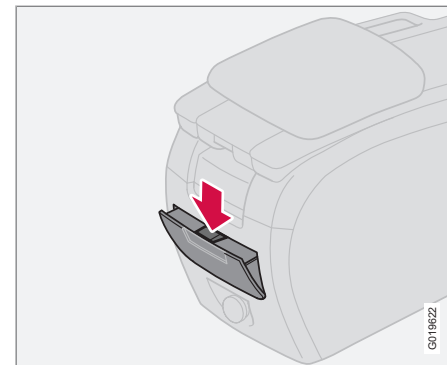

An ashtray is located towards the rear of the tunnel console.

Open the ashtray by pulling the top edge of the cover.

Emptying the ashtray:

1. Press in the catch, see preceding illustration, and tilt the cover up.
2. Then lift the ashtray out.



Rear seat

Head restraint, rear

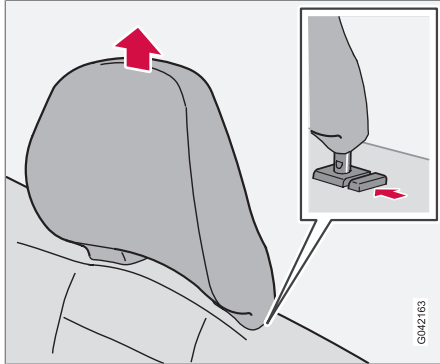

G042163

All head restraints can be adjusted vertically to suit the height of the passenger. The upper edge of the head restraint should be aligned with middle of the back of the head. Raise the head restraint as necessary.

To lower the head restraint, press the button by the right-hand pillar at the same time as pushing down the head restraint. To remove the head restraint, the button by the right-hand pillar must be pressed while lifting out the head restraint.

Lowering the rear seat backrest

! IMPORTANT

There must be no objects on the rear seat when the backrest is to be folded down. The seat belts must not be connected either. Otherwise there is a risk of damaging the rear seat upholstery.

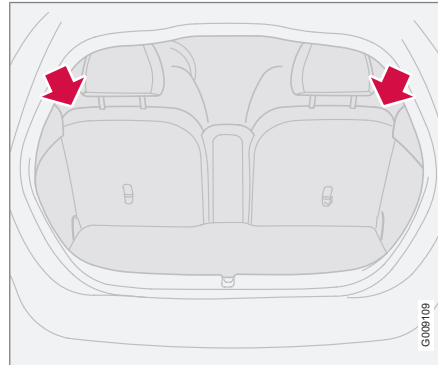

G008109

The rear seat backrests can be tipped forwards together, or individually, to make it easier to transport long objects.

Lowering the backrest

1. Pull the lock catch up and forward to release the backrest. A red indicator (A)

shows that the backrest is no longer locked in place.

2. Fold the backrest forward.

Raising the backrest

1. Fold up the backrest.
2. Place the seatbelt over the backrest.
3. Press the backrest backwards into locked position.
4. Check that the backrest is locked.

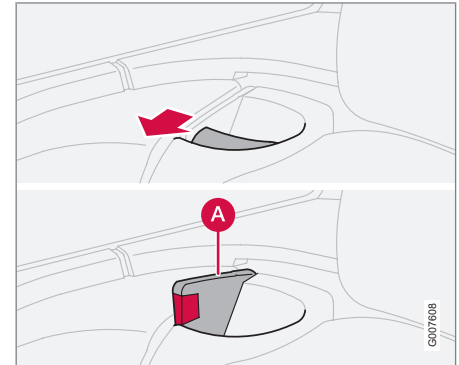

G007608

**Rear seat****⚠ WARNING**

Place the belt straps over the backrests before folding them back to their secured positions.

i NOTE

When the backrest has been raised, the red indicator (A) should no longer be showing. If it is still showing then the backrest is not locked in place.

long load. The armrest folds down when one of the backrests is folded down.

For securing loads, see page 187.

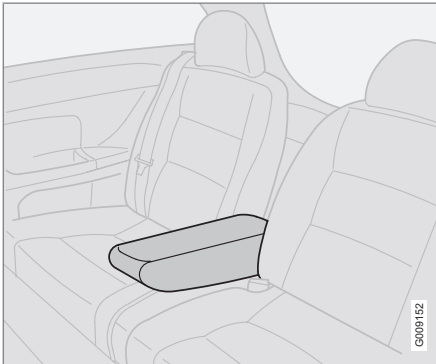
Armrest in the rear seat

The armrest in the rear seat can be folded down for passenger comfort or to make space for a



Cargo area

Soft cargo cover*

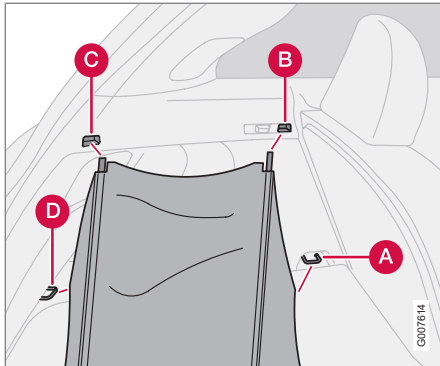

Soft cargo cover.

The cargo cover is pulled over the luggage and secured in the rear load retaining eyelets. Undo (D) and if necessary (C) during loading.

Attaching the cargo cover

1. Hook in the hooks in the front load retaining eyelets by the floor (A).
2. Fit the front brackets in (B) by pressing together the spring-loaded rail and fit it into place on both sides.
3. Fit the rear brackets in (C) in the same way.
4. Hook in the hooks in the rear load retaining eyelets (D).

Hanging up the cargo cover when not in use

1. Unhook the hooks from the rear load retaining eyelets (D).
2. Press the rail together and remove it from the rear bracket (C). Place the rail at the front of the cargo area floor.
3. Hook in the hooks in the rail next to the mounting points (B).

The cargo cover now hangs next to the rear seat backrest ready for the next time it is to be used.

Removing the cargo cover

1. Unhook the hooks and remove one rail at a time by pressing them together and removing them from their mounting points.
2. When all mounting points are detached the cargo cover can be rolled up and placed at the rear of the cargo area floor to make space for bulky loads.

NOTE

The cargo cover has no load-securing function. Never load anything on top of the cargo cover. For securing loads, see page 187.

Hard cargo cover*

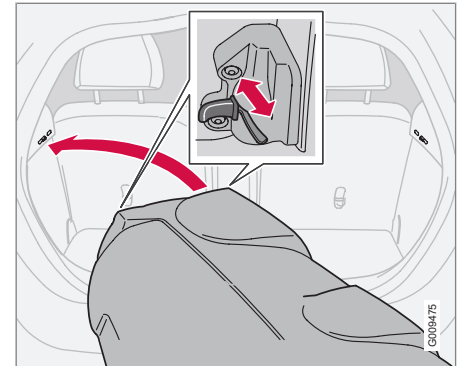

Attaching the cargo cover

1. Retract all four lock plungers by pulling the lock buttons to their end positions before lifting in the cargo cover into the cargo area. The lock plungers stop in retracted position.
2. Lift the cargo cover carefully into the cargo area sideways, turn it back around and angle the front edge up slightly.



Cargo area

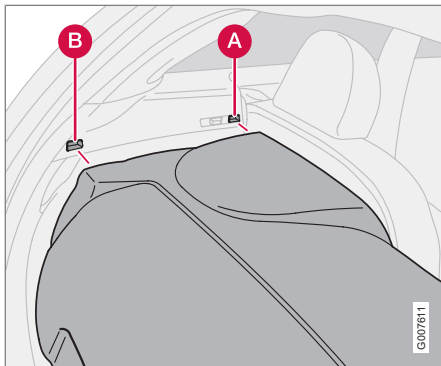

Locks and support pins.

3. Locate the front section of the two support pins behind the active locks (A) on both sides.
4. Align one of the rear locks at (B) and extend the lock plunger by moving the lock button forwards.
5. Align the other rear lock in the same way and extend the lock plunger by moving the lock button forwards.
6. Extend the front lock plungers, one at a time so that they lock in their active locks (A).

The cargo cover hatch can be raised during loading.

i NOTE

The cargo cover has no load-securing function. Never load anything on top of the cargo cover. For securing loads, see page 187.

Removing the cargo cover

1. Retract the front lock plungers at (A) to their end positions by pulling back the lock buttons on both sides.
2. Retract the rear lock plungers at (B) to their end positions by pulling back the lock buttons on both sides.
3. Lift up and turn the cargo cover before lifting it from the cargo area.

Raising the floor hatch

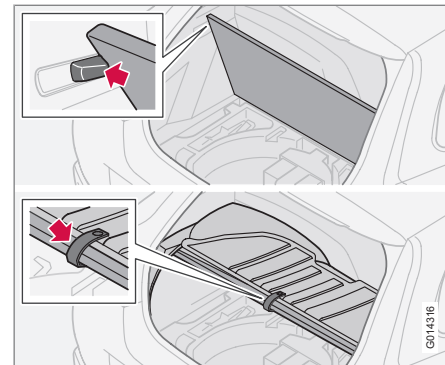

Without cargo cover

Raise the floor hatch and secure it in the lugs on both sides.

With hard cargo cover

Raise the hatch on the cargo cover. Then raise the floor hatch and hook it into the hook located under the cargo cover.



Cargo area

Safety net*

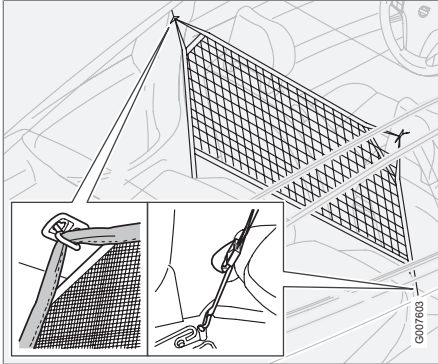

The safety net is located behind the front seat backrests. The safety net is only designed for use when the rear seat backrests are lowered. For securing loads, see page 187.

Attaching the safety net

1. Fold down the backrests on both sides, see page 116.
2. Secure the safety net in the roof panel mountings.
3. Secure the hooks in the eyes at the seatbelt floor mounting on both sides.
4. Stretch the straps if necessary.
5. Check all mountings.

Removing the safety net

1. Slacken the tension from the straps.
2. Undo the hooks from the eyes at the seatbelt floor mounting on both sides.
3. Detach the net from the mounting points in the roof panels.
4. Fold up the safety net and store it in the bag.



WARNING

Loads in the cargo area must be firmly secured even if the safety net is correctly fitted.

Load retaining eyelets*

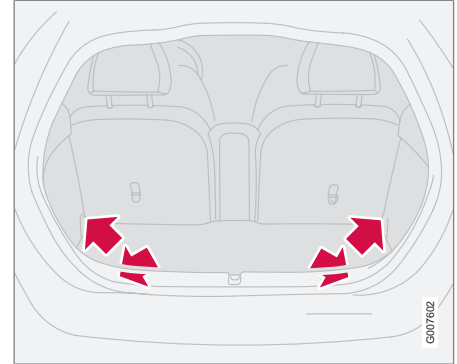

The load retaining eyelets are used to fasten straps or nets to anchor items in the cargo area.

There are two further eyelets on each side by the seatbelt slide rail that can be used when securing loads when the safety net is not in use.

For securing loads, see page 187.



A long, empty rectangular box with a thin black border, positioned horizontally near the top of the page.

Remote control key with key blade.....	124
Active locks.....	127
Keyless drive*.....	128
Battery in remote control key.....	131
Locking and unlocking.....	132
Alarm*.....	135



05

LOCKS AND ALARM





Remote control key with key blade

Remote control key

The car is supplied with 2 remote control keys.

The remote control keys contain detachable metal key blades for mechanical locking/unlocking of the driver's door and glovebox.

The key blades' unique code is available at authorised Volvo workshops, which are recommended for ordering new key blades.

A maximum of 6 remote control keys/key blades can be programmed and used for one single car.

Turn signal indication during locking/unlocking

When the car is unlocked using the remote control key or Keyless drive system, two short flashes of the direction indicators serve to indicate that unlocking was correctly performed.

For locking, the indication takes place with one long flash and only if all locks are locked, after the doors and the tailgate have been closed.

Personal preferences in the menu system can be used to deactivate the indication via the direction indicators. There will then be no visual indication as to whether the lock status is correct, see page 81.

Loss of a remote control key

If you lose a remote control key, take the car and the other remote control keys to a Volvo workshop - an authorised Volvo workshop is recommended. The code of the missing remote control key must be erased from the system as a theft prevention measure.

Immobiliser

The remote control keys are fitted with coded chips. The code must be accepted by the reader (receiver) in the ignition switch. The engine can only be started if the correct remote control key with the correct code is used.

Remote control key functions

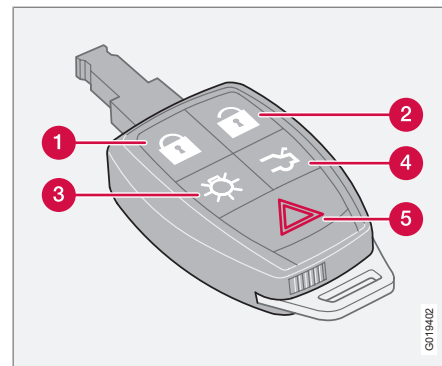

- 1 Locking** – Locks all doors and the tailgate. Press and hold (at least 2 seconds) to also close the side windows and the sunroof.

⚠ WARNING

If the sunroof and windows are closed using the remote control key, check that no one is in danger of getting hands caught.



Remote control key with key blade

- 2 Unlocking** – Unlocks the doors and the tailgate. Press and hold (at least 4 seconds) to also open the side windows.
- 3 Approach lighting** – Switches on the lighting at a distance – lights up the area around a car parked in a dark location. Press the button once to switch on the interior lighting, position/parking lamps, number plate lighting and door mirror lamps (option). The lighting is switched off automatically after 30, 60 or 90 seconds. For information on setting the delay time, see page 81.
- 4 Tailgate** – Press the button once to unlock the tailgate only¹.
- 5 Panic function** – Used to attract attention in an emergency. Press and hold the red button for at least 3 seconds or press it twice within 3 seconds to activate the direction indicators and the horn. The alarm can be deactivated with the same button, after having been armed for at least 5 seconds. Otherwise the function switches off automatically after 30 seconds.

IMPORTANT

The narrow section of the remote control key is particularly sensitive - this contains the chip. The engine cannot be started if the chip is damaged.

Detachable key blade

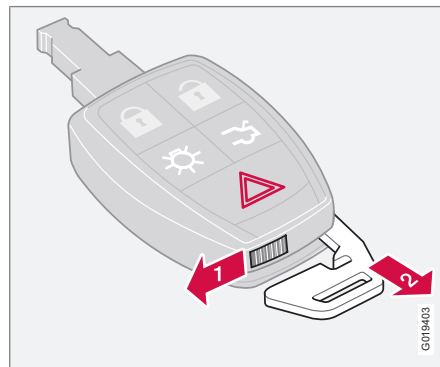

Using the remote control key's detachable key blade:

- the driver's door can be opened manually if central locking cannot be activated with the remote control key, see page 129.
- access to the glovebox can be blocked, see page 126.
- PACOS* activated/deactivated, see page 22.

Removing the key blade

To remove the key blade from the remote control key:

- 1** Slide the spring-loaded catch to the side.
- 2** Pull out the key blade at the same time.

Attaching the key blade

Be careful when inserting the key blade into the remote control key.

1. Hold the remote control key with the narrow end pointing down and lower the key blade into its slot.
2. Lightly press the key blade to lock it in position. You should hear a "click".

Unlocking doors with the key blade

If central locking cannot be activated with the remote control key, e.g. if the batteries are discharged, then the driver's door can be unlocked and opened as follows:

¹ The function unlocks the boot lid – it does not open.



Remote control key with key blade

1. Insert the key blade in the driver's door keyhole.
2. Turn the blade 45 degrees clockwise and open the door.

See also the figure and further information on page 129.

i NOTE

When the driver's door is unlocked using the key blade and is opened, the alarm is triggered. It is switched off by inserting the remote control key in the ignition switch, see page 136.

The glovebox can only be locked/unlocked using the remote control key's detachable key blade. (For information on the key blade, see page 125.)

- 1 ➔ Insert the key blade in the glovebox lock.
 - 2 ➔ Turn the key blade 90 degrees clockwise. The keyhole is horizontal in the locked position.
 - 3 ➔ Pull out the key blade.
- Unlocking takes place in reverse order.

i NOTE

The remote control key cannot unlock the glovebox without the key blade.

This function is particularly useful for when the car is left for service, at a hotel or similar.

Locking the glovebox

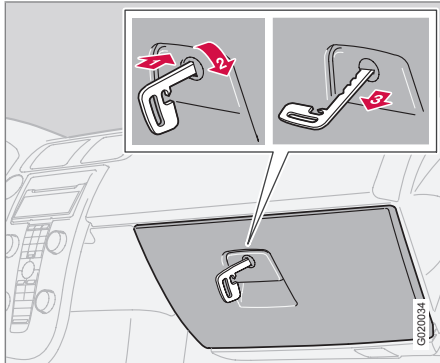

The glovebox is locked.



Active locks

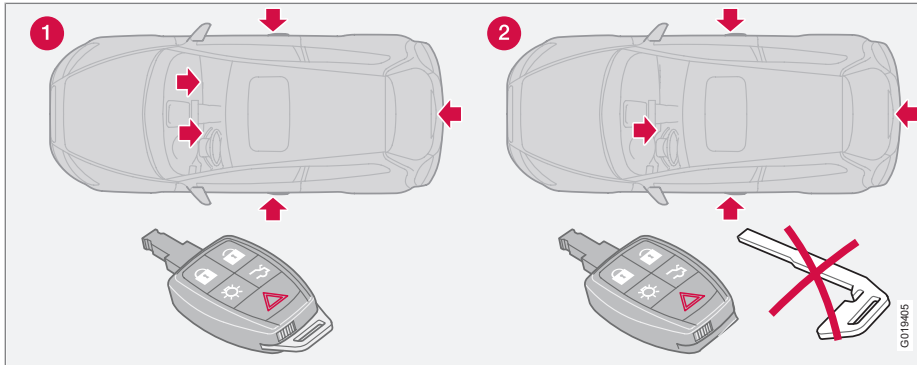

- 1 Active locks for remote control key **with** key blade.
- 2 Active locks for remote control key **with-**out key blade.



Keyless drive*

Keyless lock and ignition system

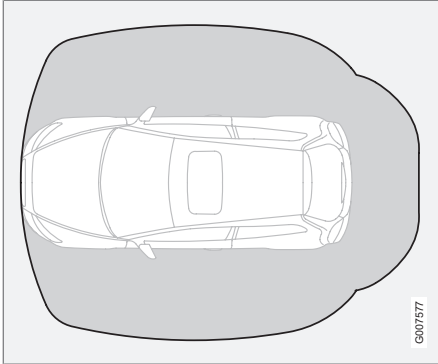

The keyless drive system allows the car to be unlocked, driven and locked without the need for a key. You simply need to have the remote control key with you in a pocket or a bag.

The system makes it easier and more convenient to open the car, for example with shopping bags in one hand and a child in the other. It saves you having to take out or look for the remote control key.

The two remote control keys incorporate the keyless drive function. You can order additional remote controls. The keyless drive system can handle up to six remote controls.

Remote control key max. 1.5 m from the car

In order to open a door or the tailgate, a remote control key must be no more than approx. 1.5 m from the car door handle or tailgate.

This means that the person who wishes to open a door must have the remote control key with him or her. It is not possible to open a door if the remote control key is on the other side of the car.

The grey area in the illustration indicates the range covered by the system's antennas.

If someone leaves the car and takes a keyless drive remote control key with them, a warning message appears on the information display and a reminder signal sounds. The warning message disappears when the remote control key is brought back to the car or when the ignition dial is turned to position **0**. The warning is only issued if the ignition dial is in position **I** or **II** after someone has opened and closed a door.

The warning message and reminder signal disappear when the remote control key is brought back to the car after one of the following actions:

- a door has been opened and closed
- the ignition dial has been turned to position **0**

- the **READ** button has been pressed.

Never leave any remote control key in the car

If a remote control key with keyless drive function is left in the car, it is made passive when the car is locked. This prevents unauthorised entry.

If someone breaks into the car and finds the remote control key, it can be activated and used again. It is therefore important to handle all remote control keys with equal care.

Interference to remote control key function

Electromagnetic fields and screening can interfere with the keyless drive system.



NOTE

Do not place/store the remote control key near a mobile phone or metal object - no closer than 10-15 cm.

If interference is experienced nonetheless, use the remote control key and key blade in the normal way, see page 124.



Keyless drive*

Locking

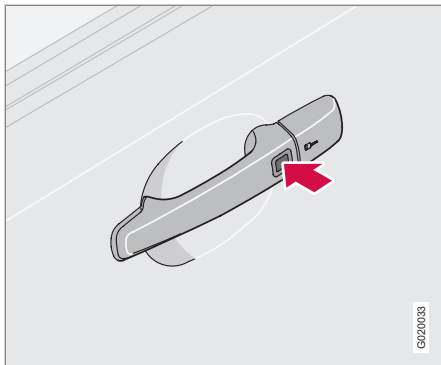

Cars with the keyless system have a button on the outside door handles.

When the remote control key is within the range covered by the system's antennas, the doors and the tailgate are locked as follows:

- Push in the lock button on one of the door handles.

All doors must be closed before the lock button is pushed in. Otherwise they will not lock.

When the car is locked, the lock buttons on the inside of the doors retract.

i NOTE

On cars with the keyless drive system and automatic transmission the gear selector must be moved to the **P** position and the ignition dial turned to the **0** position. Otherwise the car cannot be locked or alarmed.

Unlocking

When the remote control key is within the range covered by the system's antennas:

1. Open the doors by pulling the relevant handle.
2. Open the tailgate by pressing under the tailgate opening button and lift the tailgate.

If for some reason the keyless drive function in the remote control key is not operating, the car can be unlocked using the remote control key functions, see page 124.

Power seat – remote control key with memory function

If several people with keyless drive remote control keys get into the car, then the driver's seat will be adjusted for the person who opens the door first.

Unlocking doors with the key blade

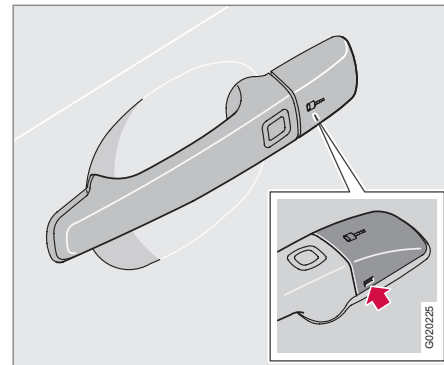

If central locking cannot be activated with the remote control key, e.g. if the batteries are discharged, then the driver's door can be opened as follows:

1. To access the keyhole: Carefully prize out the plastic cover in the handle by inserting the key blade in the hole on the bottom of the cover.
2. Unlock the door using the key blade.



Keyless drive*

NOTE

When the driver's door is unlocked using the key blade and is opened, the alarm is triggered. It is switched off by inserting the remote control key in the ignition switch, see page 136.

Antenna location

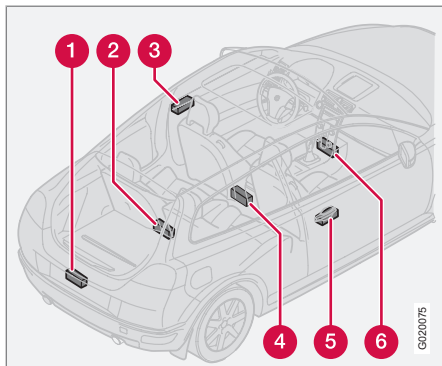

The keyless system has a number of integrated antennae located around the car:

- 1 Rear bumper, inside centre
- 2 Cargo area, central and furthest in under the floor
- 3 Door handle, left

- 4 Centre console, under the rear section
- 5 Door handle, right-hand rear
- 6 Centre console, under the front section

WARNING

People with pacemaker operations should not come closer than 22 cm to the keyless system's antennae with their pacemaker. This is to prevent interference between the pacemaker and the keyless system.

Personal preferences

The Keyless Drive system can have personal preferences applied, see page 81.



Battery in remote control key

Low battery in remote control key

When the battery runs down and full functionality cannot be guaranteed, the information symbol  and display show **KEY BATTERY LOW VOLTAGE** or **REMOTE BATTERY LOW VOLTAGE**.

Changing the remote control key battery

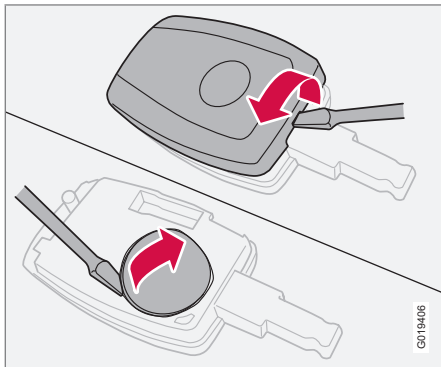

If the locks repeatedly fail to respond to signals from the remote control key at a normal distance, the battery should be replaced (type CR 2450, 3 V).

1. Place the remote control key with the keypad downward and prize up the cover using a small screwdriver.
2. Remove the cover.
3. Carefully examine how the battery's (+) and (-) sides are fitted (there is a diagram under the cover).
4. Prize out and change the battery. Avoid touching the battery and its terminals with your fingers.
5. Refit the cover and press it in.
 - > Dispose of the old battery in an environmentally-responsible manner.



Locking and unlocking

Locking/unlocking the car from outside

For cars with the Keyless system, see page 128.

Unlocking

Using the remote control key's unlock button the car can be unlocked in two different ways (select in personal settings, see page 81):

- One press unlocks the doors and the tailgate
- One press unlocks the driver's door and a second press unlocks the other doors and the tailgate.

Locking

The remote control key's lock button locks the doors and tailgate simultaneously.

NOTE

The car can be locked even if the tailgate is open - when the tailgate is then closed there is a risk that the keys will be locked in*.

WARNING

Be aware of the risk of being locked in the car when it is locked from the outside using the remote control key - it is then not possible to open any of the doors from the inside with the door controls. Read more about this in the section "Deadlocks" later on.

Rapid closing

Press and hold (at least 2 seconds) on the remote control key's lock button to close all windows and sunroof* at the same time.

Tailgate

Unlocking

Unlocking tailgate only:

- Press the remote control key's button to unlock the tailgate.

Locking

If the doors are locked when the tailgate is closed then it remains unlocked. Lock with the remote control key's lock button or from inside with the central locking button in order to lock both doors and the tailgate.

Automatic relocking

If none of the doors or the tailgate is opened within 2 minutes of unlocking, all are locked again automatically (does not apply to locking from inside). This function reduces the risk that the car is left unlocked unintentionally. (For cars with alarm, see page 136.)

Locking/unlocking the car from inside

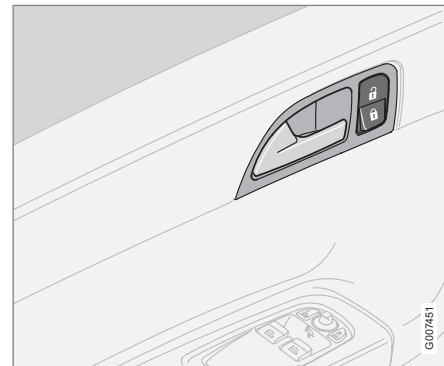

With the central locking button on the driver's door, the doors and tailgate can be locked or unlocked simultaneously.

Unlocking

- Press the upper section of the central locking button .



Locking and unlocking

Global opening

- Press the upper section of the central locking button .

A long press (at least 4 seconds) also opens all the side windows simultaneously - for example, to quickly ventilate the passenger compartment during hot weather.

Locking

- Press the lower section of the central locking button .

Press and hold (at least 2 seconds) to also close all windows and the sunroof* at the same time.

Opening the doors

When the doors are locked from the inside:

- Pull the handle twice to unlock and open the door.

Automatic locking

When the speed of the car exceeds 7 km/h the doors and tailgate are locked automatically.

When the function is activated and the doors have been locked they can be opened in two ways:

- Pull one of the door handles twice
- Press the upper section of the central locking button  and pull the door handle.

The function can be activated/deactivated by means of personal preferences, see page 81.

Deadlocks*¹

When deadlocked, the doors cannot be opened from the inside if they are locked with the remote control key.

The deadlocks are activated with the remote control key and are set after a 10-25 second delay after the doors have been locked.

The car can only be unlocked from a deadlock state with the remote control key. The driver's door can also be unlocked manually with the remote control key's detachable key blade - see page 125.



WARNING

Do not allow anyone to remain in the car without first deactivating the deadlocks in order to avoid the risk of anyone being locked in.

Temporary deactivation

If someone is going to stay in the car but the doors must be locked from the outside, then the deadlocks function can be temporarily switched off.

¹ Only in combination with alarm.



Locking and unlocking

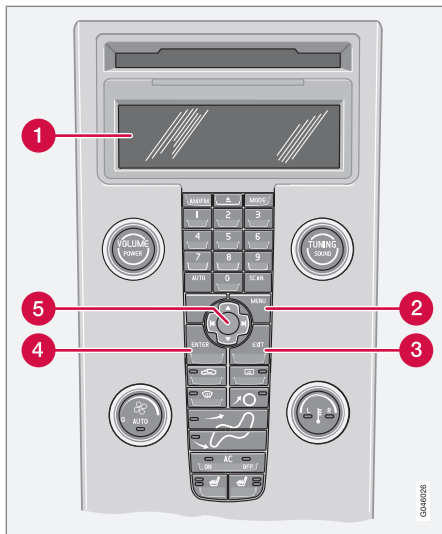

Active menu options are indicated with a cross.

- 1 Display
- 2 **MENU**
- 3 **EXIT**
- 4 **ENTER**
- 5 Navigation

Deactivation is carried out as follows:

1. Access the menu system under **CAR SETTINGS** (for a detailed description of the menu system, see page 81).
2. Select **REDUCED GUARD**.
3. Select **Activate once**: The instrument panel display shows the message **REDUCED GUARD SEE MANUAL** and the deadlocks function is switched off when the car is locked.

or

Select **Ask on exit**: Each time the key is turned to position **0** the audio system display shows the message **Reduced guard ask on exit Press ENTER to reduce guard until engine is started Press EXIT to cancel** - select one of the options:



NOTE

- Remember that the alarm is activated when the car is locked.
 - If any of the doors are opened from the inside then the alarm is triggered.
- If the deadlocks function shall be switched off: Press **ENTER** and lock the car. Note that the alarm's* movement and tilt detectors are switched off at the same time, see page 136.

The next time the remote control key is turned to key position **II** the system is reset to zero and the instrument panel display shows the message **FULL GUARD** at which the deadlocks function and the alarm's movement and tilt detectors* are re-engaged.

or

- If the locking system shall not be changed: Select no options at all and lock the car. Or press **EXIT** and lock the car.

**Alarm*****Alarm system**

When the alarm is armed, it continually monitors all alarm inputs.

The alarm is triggered if:

- a door, the bonnet or tailgate opens
- a non-approved key is used in the ignition or if an attempt is made to force the lock
- a movement is detected in the passenger compartment (if fitted with a movement detector)
- the car is raised or towed away (if fitted with a tilt detector)
- the battery's cable is disconnected
- anyone tries to disconnect the siren
- the rear window is broken.

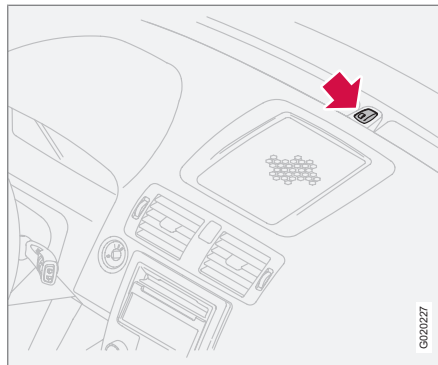
Alarm indicator

A red LED on the top of the instrument panel indicates the alarm system's status:

- LED not lit – the alarm is not armed.
- The LED flashes once every other second – Alarm is armed.
- The LED flashes rapidly after disarming the alarm and until key position II is activated – the alarm has been triggered.

If there is a fault in the alarm system, a message appears on the display. At which point you should contact a workshop - an authorised Volvo workshop is recommended.

NOTE

Do not attempt to repair or modify alarm system components. All such attempts could affect the terms of insurance.

Arming the alarm

- Press the remote control key lock button. A long flash from the car's direction indicators confirms that the alarm is armed and that the doors are locked.

IMPORTANT

The alarm is fully armed when the car's direction indicators have made one long flash and the LED on the instrument panel flashes once every other second.

Disarming the alarm

- Press the remote control key unlock button. Two short flashes from the car's direction indicators confirm that the alarm is disarmed and that the doors are unlocked.



Alarm*

Automatic re-arming of the alarm

This function prevents the car being left with the alarm disarmed unintentionally.

If the car is unlocked with the remote control key (and the alarm is disarmed) but none of the doors or the tailgate is opened within 2 minutes, then the alarm is automatically re-armed. The car is relocked at the same time.

Deactivating a triggered alarm

- Press the unlock button on the remote control key or insert the key in the ignition switch.

Confirmation is given by two short flashes from the direction indicators.

If the remote control key's batteries are discharged then the alarm can be deactivated by unlocking the driver's door manually, inserting the remote control key in the ignition switch and turning it to key position **II**.

Remote control key not working

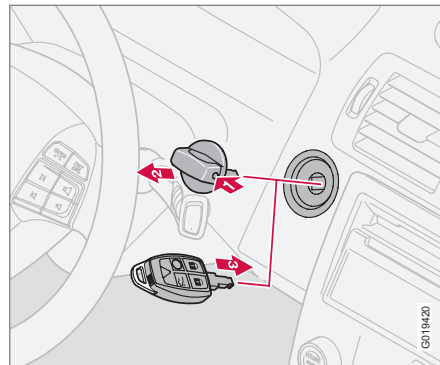

If the alarm cannot be deactivated with the remote control key, e.g. if the key's battery is discharged - the car can be unlocked, disarmed and the engine started as follows:

1. Open the driver's door with the detachable key blade. The alarm is triggered and the siren sounds.
2. On cars with the keyless drive system: First remove the knob by pressing in the catch (1) and pulling out (2).
3. Insert the remote control key in the ignition switch (3). The alarm is deactivated. The alarm light flashes rapidly until the remote control key is turned to key position **II**.

Alarm signals

When the alarm is triggered, the following happens:

- A siren sounds for 25 seconds or until the alarm is deactivated. The siren has its own battery and works independently of the car battery.
- The direction indicators flash for 5 minutes or until the alarm is switched off.

Reduced alarm level

To avoid accidental triggering of the alarm - e.g. if a dog is left in a locked car or during transport on a car train or car ferry - the movement and tilt detectors should be temporarily deactivated.

The procedure is the same as with the temporary disengaging of deadlocks - see page 133

Testing the alarm system

Testing the movement detector* in the passenger compartment

1. Open all the windows.
2. Engage the alarm function with the remote control key's lock button. Active alarm function is confirmed with a slowly flashing alarm indicator.
3. Please wait 30 seconds.

**Alarm***

4. Test the movement detector by lifting out a bag from a seat for example.
 - > A siren should sound and all direction indicators should flash.
 5. Deactivate the alarm by unlocking the car with the remote control key.
4. Open the bonnet with the handle under the dashboard.
 - > A siren should sound and all direction indicators should flash.
 5. Deactivate the alarm by unlocking the car with the remote control key.

Test of alarm for doors

1. Engage the alarm function with the remote control key's lock button.
2. Please wait 30 seconds.
3. Unlock the driver's door with the detachable key blade.
4. Open one of the doors.
 - > A siren should sound and all direction indicators should flash.
5. Deactivate the alarm by unlocking the car with the remote control key.

Test of alarm for bonnet

1. Sit in the car and deactivate the movement detector, see the previous section "Reduced alarm level".
2. Remain sitting in the car and engage the alarm function with the remote control key's lock button.
3. Please wait 30 seconds.

General.....	140
Refuelling.....	142
Alcolock*.....	146
Starting the engine.....	150
Starting the engine – Flexifuel.....	152
Keyless drive*.....	154
Manual gearbox.....	155
Automatic gearbox.....	156
DRIVE Start-Stop*.....	161
Brake system.....	165
DSTC – Stability and traction control system*.....	167
Park Assist*.....	169
BLIS*.....	171
Towing and recovery.....	174
Start assistance.....	178
Driving with a trailer.....	179
Towing equipment*.....	181
Detachable towbar*.....	183
Loading.....	187
Adjusting headlamp pattern.....	188



06

STARTING AND DRIVING





General

Economical driving

Driving economically means driving smoothly while thinking ahead and adjusting your driving style and speed to the prevailing conditions.

- Drive in the highest gear possible, adapted to the current traffic situation and road - lower engine speeds result in lower fuel consumption.
- Avoid driving with open windows.
- Avoid sudden unnecessary acceleration and heavy braking.
- Remove unnecessary items from the car - the greater the load the higher the fuel consumption.
- Use engine braking to slow down, when it can take place without risk to other road users.
- A roof load and ski box increase air resistance, leading to higher fuel consumption - remove the load carriers when not in use.
- Do not run the engine to operating temperature at idling speed, but rather drive with a light load as soon as possible - a cold engine consumes more fuel than a warm one.

For more information and further advice, see the pages 13 and 295.

WARNING

Never switch off the engine while moving, such as downhill, this deactivates important systems such as the power steering and brake servo.

Driving in water

The car can be driven through water at a maximum depth of 25 cm at a maximum speed of 10 km/h. Extra caution should be exercised when passing through flowing water.

IMPORTANT

Engine damage can occur if water enters the air filter.

In greater depths, water can enter the transmission. This reduces the lubricating ability of the oils and shortens the service life of the systems.

When driving in water, maintain a low speed and do not stop the car. When the water has been passed, depress the brake pedal lightly and check that full brake function is achieved. Water and mud for example can make the brake linings wet resulting in delayed brake function.

- Clean the electric contacts of the electric engine block heater and trailer coupling after driving in water and mud.

IMPORTANT

Do not let the car stand with water over the sills for any long period of time. This could cause electrical malfunctions.

In the event of stalling in water, do not try to restart. Tow the car from the water.

Engine, gearbox and cooling system

Under special conditions, for example hard driving in hilly terrain and hot climate, there is a risk that the engine and drive system may overheat - in particular with a heavy load.

For supplementary information about overheating when driving with a trailer - see page 179.

- Remove any auxiliary lamps from in front of the grille when driving in hot climates.
- In the event of a risk of overheating a built-in protection function in the gearbox is activated which, amongst other things, illuminates the instrument panel's yellow information lamp and there is a text message displayed there regarding appropriate action - follow the recommendation given.



General

- If the temperature gauge for the engine's cooling system goes into the red zone - stop and let the engine idle for a few minutes.
- If the car overheats, the air conditioning may be switched off temporarily.
- Do not turn the engine off immediately you stop after a hard drive.

NOTE

It is normal for the engine's cooling fan to operate for a while after the engine has been switched off.

IMPORTANT

The operating temperature of the gearbox is checked in order to prevent damage to any of the drive system's components. In the event of a risk of overheating a warning symbol illuminates on the instrument panel combined with a text message - In which case, follow the recommendation given.

Diesel engine

When driving under heavy load in a hot climate, the engine cooling fan can be replaced with one of a greater capacity than the standard

model¹. Check with your nearest Volvo dealer regarding the options for your car.

Open tailgate**WARNING**

Do not drive with the tailgate open. Toxic exhaust fumes can be drawn into the car through the cargo area.

Do not overload the battery

The electrical functions in the car load the battery to varying degrees. Avoid having the remote control key in key position II when the engine is switched off. Instead use the I mode - which uses less power.

Note that the 12 volt outlet in the cargo area supplies power even when the remote control key has been removed from the ignition switch.

Also, be aware of different accessories that load the electrical system. Do not use functions which use a lot of power when the engine is switched off. Examples of such functions are:

- ventilation fan
- windscreen wiper
- audio system (high volume)

- headlamps.

If the battery voltage is low the information display shows the text **LOW BATTERY POWER SAVE MODE**. The energy-saving function then shuts down certain functions or reduces certain functions such as the ventilation fan and/or audio system.

- In which case, charge the battery by starting the engine and then running it for at least 15 minutes - battery charging is more effective during driving than running the engine at idling speed while stationary.

Slippery driving conditions

Practise driving on slippery surfaces under controlled conditions to learn how the car reacts.

¹ For certain engines.

Refuelling

Opening the fuel filler flap

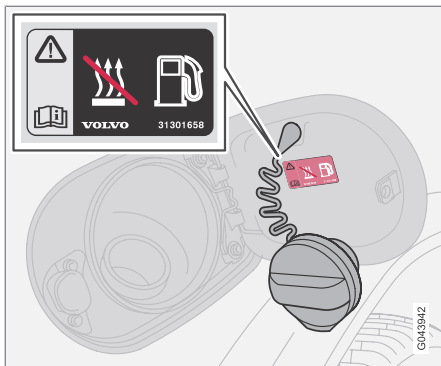

Don not forget to switch off the fuel-driven heater before refuelling!

Open the fuel filler flap with the button on the lighting panel, see page 57. The engine must be switched off before the flap can be opened. The fuel flap is located on the rear right wing.

Closing

Push in the flap until you hear a click.

Fuel cap

1. Turn the fuel cap until an obvious resistance is felt.
2. Turn past the resistance until it comes to a stop.

3. Take out the cap.
4. Hang up the cap on the inside of the fuel filler flap.

NOTE

Put the petrol cap back on after refuelling. Turn until one or more clear clicks are heard.

Filling up with fuel

Do not overfill the tank but fill until the pump nozzle cuts out.

NOTE

Excess fuel in the tank can overflow in hot weather.

Fuel of a lower quality than that specified should not be used as engine power and fuel consumption could be negatively affected, for more information see the following section Fuel.

General information on fuel

WARNING

Always avoid inhaling fuel vapour and getting fuel splashes in the eyes.

In the event of fuel in the eyes, remove any contact lenses and rinse the eyes in plenty of water for at least 15 minutes and seek medical attention.

Never swallow fuel. Fuels such as petrol, bioethanol and mixtures of them and diesel are highly toxic and could cause permanent injury or be fatal if swallowed. Seek medical attention immediately if fuel has been swallowed.

WARNING

Fuel which spills on to the ground can be ignited by the exhaust fumes.

Switch off the fuel-driven heater before starting to refuel.

Never carry an activated mobile phone when refuelling. The ring signal could cause spark build-up and ignite petrol fumes, leading to fire and injury.

**! IMPORTANT**

Mixing different types of fuel or the use of fuel not recommended invalidates Volvo's guarantees, and any associated service agreement. This applies to all engines.

NOTE: It does not apply to cars with engines that are adapted to run on ethanol fuel (E85).

For information on fuel consumption and tank volume - see page 295.

Catalytic converter

The purpose of the catalytic converter is to purify exhaust gases. It is located in the flow of exhaust gases close to the engine so that it quickly reaches operating temperature. The catalytic converter consists of a monolith (ceramic or metal) with channels. The channel walls are lined with a thin layer of platinum/rhodium/palladium. These metals act as catalysts, i.e. they participate in and accelerate a chemical reaction without being used up themselves.

Lambda-sond™ oxygen sensor

The Lambda-sond is part of a control system intended to reduce emissions and improve fuel economy.

An oxygen sensor monitors the oxygen content of the exhaust gases leaving the engine. This value is fed into an electronic system that con-

tinuously controls the injectors. The ratio of fuel to air directed to the engine is continuously adjusted. These adjustments create optimal conditions for efficient combustion of harmful emissions (hydrocarbons, carbon monoxide and nitrous oxides) using the three-way catalytic converter.

Petrol

Petrol must meet the EN 228 standard. Most engines can be run with octane ratings of 91, 95 and 98 RON.

- 91 RON must not be used for 4-cylinder engines and should only be used in exceptional cases with other engines.
- 95 RON can be used for normal driving.
- 98 RON is recommended for optimum performance and minimum fuel consumption.

When driving in temperatures above +38 °C, fuel with the highest possible octane rating is recommended for optimum performance and fuel economy.

! IMPORTANT

- Always refuel with unleaded petrol so as not to damage the catalytic converter.
- Do not use additives not recommended by Volvo.

Bioethanol E85

Do not modify the fuel system or its components, and do not replace components with parts that are not specifically designed for use with bioethanol.

! WARNING

Methanol must not be used. A decal on the inside of the fuel filler flap shows the correct alternative fuel.

The use of components not designed for bioethanol engines could cause fire, injury or engine damage.

Reserve fuel can

The reserve fuel can should be filled with petrol, see the NOTE box, page 152.

! IMPORTANT

Make sure the reserve fuel can is securely fastened and that its cap is sealed.

! WARNING

Ethanol is sensitive to sparks, and explosive gases could form in the reserve fuel can if it is refuelled with ethanol.



Refuelling

Diesel

Diesel must meet the EN 590 or JIS K2204 standards.

! IMPORTANT

Only ever use fuel that fulfils the European diesel standard.

! IMPORTANT

Diesel type fuels which must not be used: special additives, Marine Diesel Fuel, fuel oil, RME¹ (Rape Methyl Ester) and vegetable oil. These fuels do not fulfil the requirements in accordance with Volvo recommendations and generate increased wear and engine damage that is not covered by the Volvo warranty.

Diesel engines are sensitive to contaminants, such as excessively high volumes of sulphur particles for example. Only use diesel fuel from well-known producers. Never use diesel of dubious quality.

At low temperatures (-40 °C to -6 °C), a paraffin precipitate may form in the diesel fuel, which may lead to ignition problems. Special diesel fuel designed for low temperatures around freezing point is available from the major oil

companies. This fuel is less viscous at low temperatures and reduces the risk of paraffin precipitate.

! IMPORTANT

Use special winter grade fuel during cold months.

The risk of condensation in the fuel tank is reduced if the tank is kept well filled. When refuelling, check that the area around the fuel filler pipe is clean. Avoid spilling fuel onto the paintwork. Wash off any spillage with detergent and water.

! IMPORTANT

The sulphur content must be a maximum of 50 ppm.

Empty tank

The design of the fuel system in a diesel engine means that if the vehicle runs out of fuel, the tank may need to be vented in the workshop in order to restart the engine after fuelling.

Once the engine has stopped due to fuel starvation, the fuel system needs a few moments to carry out a check. Do this before starting the

engine, once the fuel tank has been filled with diesel:

1. Insert the remote control key in the ignition switch and turn to key position **II** (see page 150).
2. Wait approx. 1 minute.
3. To start the engine: Depress the brake and/or clutch pedal, and turn the remote control key to start position **III**.

Draining condensation from the fuel filter

The fuel filter separates condensation from the fuel. Condensation can disrupt engine operation.

The fuel filter must be drained at the intervals specified in the Service and Warranty Booklet or if you suspect that the car has been filled with contaminated fuel.

! IMPORTANT

Certain special additives remove the water separation in the fuel filter.

Diesel particle filter (DPF)

Diesel cars may be equipped with a particle filter, which results in more efficient emission control. The particles in the exhaust gases are collected in the filter during normal driving. So-

¹ Diesel fuel may contain a certain amount of RME, but further amounts must not be added.



called "regeneration" is started in order to burn away the particles and empty the filter. This requires the engine to have reached normal operating temperature.

Regeneration of the filter takes place automatically and normally takes 10-20 minutes. It may take a little longer at a low average speed. Fuel consumption may increase slightly during regeneration.

The rear window heating may be activated automatically to increase the load on the engine during regeneration without warning.

Regeneration in cold weather

If the car is frequently driven short distances in cold weather then the engine does not reach normal operating temperature. This means that regeneration of the diesel particle filter does not take place and the filter is not emptied.

When the filter has become approximately 80% full of particles, the yellow information symbol on the instrument panel illuminates, and the message **SOOT FILTER FULL SEE OWNER MANUAL** is shown on the instrument panel display.

Start regeneration of the filter by driving the car until the engine reaches normal operating temperature, preferably on a main road or motorway. The car should then be driven for approximately 20 minutes more.

NOTE

A smaller reduction of engine power may be noticed temporarily during regeneration.

When regeneration is complete the message is cleared automatically.

IMPORTANT

If the filter fills up it may be incapable of functioning. Then it can be difficult to start the engine and there is a risk that the filter will have to be replaced.

Use the parking heater* in cold weather so that the engine reaches normal operating temperature more quickly.



Alcolock*

General information on the Alcolock

The function of the Alcolock¹ is to prevent the car from being driven by individuals under the influence of alcohol. Before the engine can be started the driver must take a breath test that verifies that he/she is not under the influence of alcohol. Alcolock calibration takes place in accordance with each market's limit value in force for driving legally.

WARNING

The Alcolock is an aid and does not exempt the driver from responsibility. It is always the responsibility of the driver to be sober and to drive the car safely.

Functions

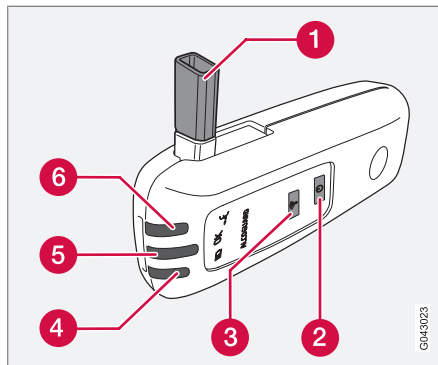

1. Nozzle for breath test.
2. Switch.
3. Transmission button.
4. Lamp for battery status.
5. Lamp for result of breath test.
6. Lamp indicates ready for breath test.

Operation

Battery

Alcolock indicator lamp (4) shows battery status:

Indicator lamp (4)	Battery status
Green flashing	Charging in progress
Green	Fully charged
Yellow	Semi-charged
Red	Discharged - fit the charger in the holder or connect the power supply cable from the glovebox.

NOTE

Store the Alcolock in its holder. This will keep the built-in battery fully charged and the Alcolock is activated automatically when the car is opened.

¹ Also called Alcoguard.

* Option/accessory, for more information, see Introduction.



Storage

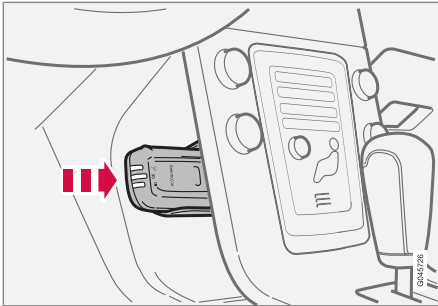

Handset storage and charging station.

- To detach the Alcolock handset, press it gently into its holder and then release - it then springs out and can be removed from the holder.
- Replace the handset in the holder by sliding it in until it "clicks" into place.
- Store the handset in the holder - this provides best protection and its batteries are kept fully charged.

Before starting the engine

The Alcolock is activated automatically and is then ready for use when the car is opened.

1. When the indicator lamp (6) is green the Alcolock is ready for use.
2. Withdraw the Alcolock from its holder. If the Alcolock is outside the car when it is

unlocked then it must first be activated with the switch (2).

3. Fold up the nozzle (1), take a deep breath and blow with an even pressure until a "click" is heard after approx. 5 seconds. The result will be one of the alternatives in the following table **Result after breath test**.
4. If no message is shown then the transmission to the car may have failed - in which case, press the button (3) to transmit the result to the car manually.
5. Fold down the nozzle and refit the Alcolock in its holder.
6. Start the engine following an approved breath test within 5 minutes - otherwise it must be repeated.

Result after breath test

Indicator lamp (5) + Display text	Specification
Green lamp + ALCOGUARD APPROVED TEST	Start the engine - no alcohol content measured.
Yellow lamp + ALCOGUARD APPROVED TEST	Engine starting possible - measured alcohol content is above 0.1 promille but below the limit value in force ^A .
Red lamp + DISAPPROVED TEST WAIT 1 MINUTE	Engine starting not possible - measured alcohol content is above the limit value in force ^A .

^A Limits vary between countries, so find out what limits apply. See also the section entitled General information on the Alcolock on page 146.

i NOTE

After a completed period of driving, the engine can be restarted within 30 minutes without a new breath test.



Alcolock*

To bear in mind

Before the breath test

In order to obtain correct function and as accurate a measurement result as possible:

- Avoid eating or drinking approx. 5 minutes before the breath test.
- Avoid excess windscreen washing - the alcohol in the washer fluid may result in an incorrect measurement result.

Change of driver

In order to ensure that a new breath test is carried out in the event of a change of driver - depress the switch (2) and the send button (3) simultaneously for approx. 3 seconds. At which point the car returns to start inhibition mode and a new approved breath test is required before starting the engine.

Calibration and service

The Alcolock must be checked and calibrated at a workshop² every 12 months.

30 days before recalibration is necessary the display shows **ALCOGUARD CALIBR. REQUIRED**. If calibration is not carried out within these 30 days then normal engine starting will be blocked - only starting with the

Bypass function will then be possible, see page 148 section Emergency situation.

The message can be cleared by pressing the send button (3) once. Otherwise it goes out on its own after approx. 2 minutes but then reappears each time the engine is started - only recalibration at a workshop² can clear the message permanently.

Cold or hot weather

The colder the weather the longer it takes before the Alcolock is ready for use:

Temperature (°C)	Maximum heating time (seconds)
+10 to +85	10
-5 to +10	60
-40 to -5	180

At temperatures below -20 °C or above +60 °C the Alcolock requires additional power supply. The display shows **ALCOGUARD INSERT POWER CABLE**. In which case, connect the power supply cable from the glovebox and wait until indicator lamp (6) is green.

In extremely cold weather the heating time can be reduced by taking the Alcolock indoors.

Emergency situation

In the event of an emergency situation or the Alcolock is out of order, it is possible to bypass the Alcolock in order to drive the car.



NOTE

All Bypass activation is logged and saved in memory, see page 10 in the section, Recording data.

After the Bypass function has been activated the display shows **ALCOGUARD BYPASS ENABLED** the whole time while driving and can only be reset by a workshop².

The Bypass function can be tested without the error message being logged - in which case, carry out all the steps without starting the car. The error message is cleared when the car is locked.

When the Alcolock is installed, either the Bypass or Emergency function is selected as the bypassing option. This setting can be changed afterwards at a workshop².

² An authorised Volvo workshop is recommended.

* Option/accessory, for more information, see Introduction.



Activating the Bypass function

- Depress and hold the left-hand stalk switch **READ** button and the button for hazard warning flashers simultaneously for approx. 5 seconds - the display first shows **BYPASS ACTIVATED WAIT 1 MINUTE** and then **ALCOGUARD BYPASS ENABLED** - after which the engine can be started.

This function can be activated several times. The error message shown during driving can only be cleared at a workshop².

Activating the Emergency function

- Depress and hold the left-hand stalk switch **READ** button and the button for hazard warning flashers simultaneously for approx. 5 seconds - the display shows **ALCOGUARD BYPASS ENABLED** and the engine can be started.

This function can be used once, after which a reset must be made at a workshop².

Symbols and display messages

In addition to the previously described messages, the combined instrument panel's display can also show the following:

Display text	Meaning/Action
ALCOGUARD RESTART POSSIBLE	The engine has been switched off for less than 30 minutes - engine starting possible without new test.
ALCOGUARD SERVICE REQUIRED	Contact a workshop ² .
ALCOGUARD NO SIGNAL	Transmission failed - send manually with button (3) or take a new breath test.
ALCOGUARD INVALID TEST	Test failed - take a new breath test.
ALCOGUARD BLOW LONGER	Blowing too short - blow for longer.
ALCOGUARD BLOW SOFTER	Blowing too hard - blow more gently.

Display text	Meaning/Action
ALCOGUARD BLOW HARDER	Blowing too weak - blow harder.
ALCOGUARD WAIT PREHEATING	Heating not finished - wait for text ALCOGUARD BLOW 5 SECONDS .

² An authorised Volvo workshop is recommended.



Starting the engine

Before starting the engine

- Apply the parking brake.

Note that if the car is equipped with an alcolock then a breath test must first be approved before the engine can be started, see page 146.

Automatic gearbox

- Move the gear selector in position **P** or **N**.

Manual gearbox

Put the gear lever in neutral and hold the clutch pedal fully depressed. This is particularly important in very cold conditions.

WARNING

Never remove the remote control key from the ignition switch while driving or when the car is being towed. The steering lock could otherwise be activated, making it impossible to steer the car.

The remote control key must be in key position **II** when the car is being towed.

NOTE

The idling speed can be noticeably higher than normal for certain engine types during cold starting. This is in order that the emissions system can reach normal operating temperature as quickly as possible, which minimises exhaust emissions and protects the environment.

Starting the engine

IMPORTANT

If the engine fails to start after 3 attempts - wait for 3 minutes before making a further attempt. Starting capacity increases if the battery is allowed to recover.

Petrol

- Turn the remote control key to key position **III**. If the engine does not start within 5–10 seconds, release the key and try again.

Diesel

1. Turn the remote control key to key position **II**.
 - > An indicator symbol in the combined instrument panel shows that engine preheating is underway, see page 49.

2. Turn the ignition key to position **III** when the indicator symbol goes out.

Autostart *

With the autostart function, there is no need to hold the remote control key (or ignition dial, on cars with Keyless Drive - see page 128) in key position **III** until the engine has started.

- Turn the key to key position **III** and release it - the starter motor then works automatically until the engine has started.

NOTE

If the diesel engine is started in extreme cold without waiting for engine preheating, then the automatic start sequence can be delayed for a couple of seconds.

Key positions

0 – Locked position

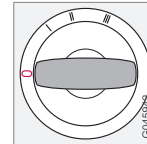

The steering lock is activated when the remote control key is removed from the ignition switch.



Starting the engine

I – Radio position

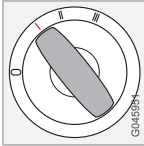

Steering lock deactivated. Certain functions can be used. The engine's electrical system is not activated.

II – Driving position

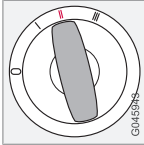

The remote control key's position when driving. The whole electrical system is engaged.

III – Start position

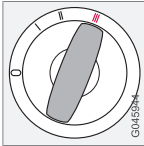

The starter motor is activated. The remote control key is released when the engine has started and then springs back to drive position.

A ticking sound can be heard if the key reaches an intermediate position - in which case, turn the key to position II and back to get rid of the sound.

When the steering lock is activated

If the front wheels are positioned so that there is tension in the steering lock then the information display may show a warning message

and the car cannot be started. In which case, proceed as follows:

1. Remove the remote control key from the ignition switch and turn the steering wheel so that the tension is released.
2. Hold the steering wheel in this position. Reinsert the key and make a new attempt to start the car.

WARNING

Never remove the remote control key from the ignition switch while driving or when the car is being towed. The steering lock would be activated, making it impossible to steer the car.

WARNING

Always remove the remote control key from the ignition switch when leaving the car, especially if there are children in the car.

Remote control keys and electronic immobiliser

The remote control key must not hang with other keys or metal objects on the same key ring. The electronic immobiliser could be activated accidentally.



Starting the engine – Flexifuel

General information about starting with Flexifuel

The engine is started in the same way as in a petrol-engined car, see page 150.

i NOTE

The immobiliser is activated in the event of repeated start attempts. Before a new start attempt is made the key/dial must first be turned back to position **I** or **0**.

In the event of starting difficulties

If the engine does not start at the first start attempt, proceed as follows:

1. Depress the accelerator pedal 1/3 to 1/2.
2. Turn the remote control key/ignition dial to key position **III**.
3. When the engine has started, ease the accelerator pedal gradually as the engine speed increases.

If the engine has not started after 10 seconds, second attempt

- Turn the remote control key/ignition dial to key position **III** until the engine starts, but not longer than 60 seconds.

If the engine still does not start

- Please wait for one minute, fully depress the accelerator pedal and repeat the previous procedure.

! IMPORTANT

If the engine does not start despite repeated start attempts, contact a workshop - an authorised Volvo workshop is recommended.

Engine block heater*

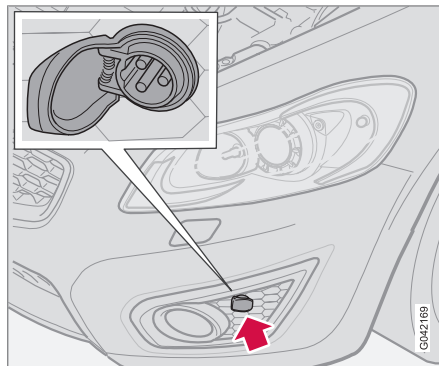

Electrical input to the engine block heater.

When the temperature is expected to be lower than -10°C and the car has been refuelled with

bioethanol E85, an engine block heater should be used for about 2 hours to facilitate the quick starting of the engine.

The lower the temperature, the longer the time required with the engine block heater. At -20°C the heater should be used for approx. 3 hours.

Cars intended for E85 have an electric engine block heater*. Starting and driving with a pre-heated engine involves significantly lower emissions and reduced fuel consumption. For this reason you should aim to use the engine block heater throughout the winter months.

! WARNING

The engine block heater is powered by high voltage. Fault tracing and repair of an electric engine block heater and its electrical connections must only be carried out by a workshop - an authorised Volvo workshop is recommended.

**Starting the engine – Flexifuel****NOTE**

Points to remember for carrying reserve fuel:

- In the event of stalling due to an empty fuel tank, bioethanol E85 from a reserve fuel can may make the engine difficult to start in extreme cold. This is avoided by filling the reserve fuel can with 95 octane petrol.

For more information on Flexifuel's bioethanol E85 fuel, see page 143.

Fuel adaptation

If the fuel tank is filled with petrol after the car has been driven on bioethanol E85 (or vice versa) then the engine may run slightly unevenly for a time. For this reason it is important to allow the engine to accustom itself (adapt) to the new fuel mixture.

Adaptation takes place automatically when the car is driven for a short period at an even speed.

**IMPORTANT**

After the fuel mixture in the tank has been changed an adaptation should be made by driving at an even speed for about 15 minutes.

If the battery has been discharged or disconnected then a slightly longer period of driving is required for the adaptation as the memory for the electronics has been cleared.



Keyless drive*

General

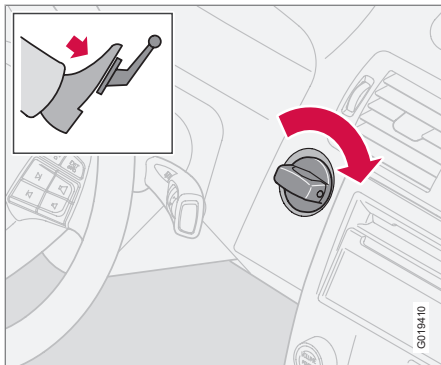

The keyless drive system allows the car to be unlocked, driven and locked without the need for a key, see page 128.

The ignition switch ignition dial is used in the same way as the remote control key. One precondition for starting the car is that the car's remote control key is located inside the passenger compartment or the cargo area.

Starting the car

- Depress the clutch pedal (cars with manual gearbox) or brake pedal (cars with automatic gearbox).

Petrol engine

- Press in and turn the ignition dial to key position III.

Diesel engine

1. First turn the ignition dial to key position II and wait until the diesel indicator symbol in the combined instrument panel goes out, see page 49.
2. Following which, turn the ignition dial to position III.

Starting with the remote control key

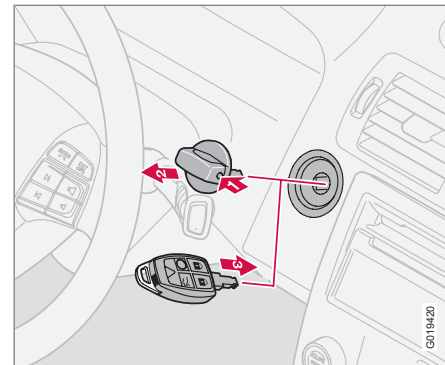

If the remote control key's battery is discharged then the Keyless Drive function does not work. In which case, start the car by using the remote control key as ignition dial.

1. Press in the catch in the ignition dial.
2. Pull the ignition dial out from the ignition switch.
3. Insert the remote control key into the ignition switch and start in the same way as with the ignition dial.



Manual gearbox

Gear positions

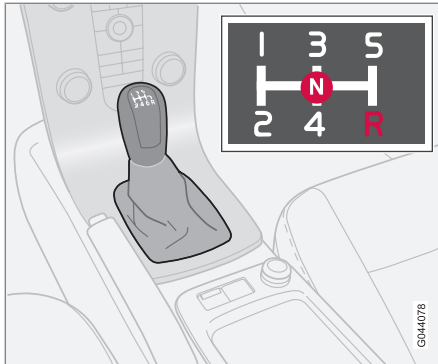

Gearshift pattern 5-speed gearbox.

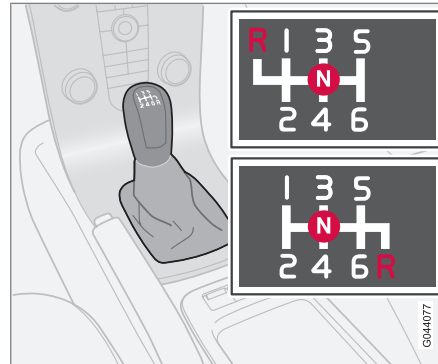

Gearshift pattern 6-speed gearbox.

The 6-speed box is available in two versions - reverse gear position differs between them. Look at the actual gearshift pattern imprinted on the gear lever.

- Depress the clutch pedal fully during each gear change.
- Take your foot off the clutch pedal between gear changes.

**WARNING**

Always apply the parking brake when parking on a slope - leaving the car in gear is not sufficient to hold the car in all situation.

Gear shift indicator - GSI*

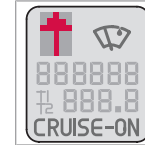

GSI - Gear Shift Indicator - advises the driver of the optimum time to change gear. The indication is given with an arrow for up and down shifting respectively in the lower information display of the combined instrument panel, see page 47.

Reverse gear inhibitor

The reverse gear inhibitor hinders the possibility of mistakenly attempting to engage reverse gear during normal forward travel.

- Start from neutral position **N** and only engage reverse gear **R** when the car is stationary.

**NOTE**

With the upper variant of the shifting pattern for 6-speed gearbox (see previous illustration) - **first press down** the gear lever in the **N** position in order to engage reverse gear.



Automatic gearbox

Geartronic automatic gear positions

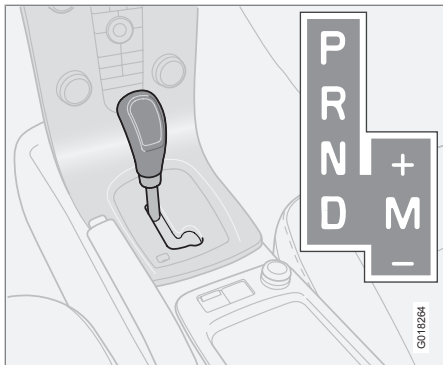

D: Automatic gear positions. **M (+/-):** Manual gear positions.

The information display shows the position of the gear selector using the following indications: **P, R, N, D, 1, 2, 3, 4, 5** or **6**, see page 47.

P – Parking position

Select position **P** when you wish to start the engine or park the car.

! IMPORTANT

The car must be stationary when position **P** is selected.

i NOTE

The brake pedal must be depressed in order to be able to disengage the gear lever from the **P** position.

The gearbox is mechanically blocked when the **P** position is engaged. Always apply the parking brake when parking the car.

! WARNING

Always apply the parking brake when parking on a slope - the automatic transmission's **P** position is not sufficient to hold the car in all situation.

R – Reverse

The car must be stationary when position **R** is selected.

N – Neutral

No gear is engaged and the engine can be started. Apply the parking brake when the car is stationary with the gear selector in position **N**.

i NOTE

The brake pedal must be depressed in order to be able to disengage the gear lever from the **N** position if the car has been stationary for more than 3 seconds.

D – Drive

D is the normal driving position. The car automatically shifts up and down depending on the level of acceleration and speed. The car must be stationary when the gear selector is moved to position **D** from position **R**.

Geartronic manual gear positions (+/-)

The driver can also change gear manually using the Geartronic automatic gearbox. The car engine-brakes when the accelerator pedal is released.

Manual gearshift mode is obtained by moving the lever to the side from position **D** to the end position at **+/-**. The information display shifts the indication from **D** to one of the figures **1 – 6**, which is equivalent to the gear that is engaged just then, see page 47.

- Move the lever forwards towards **+** (plus) to change up a gear and release it, the lever returns to its rest position between **+** and **-**.

or

- Pull the lever back towards **-** (minus) to change down a gear and release it.

The manual gearshift mode (+/-) can be selected at any time while driving.

Geartronic automatically shifts down if the driver allows the speed to decrease lower than



Automatic gearbox

a level suitable for the selected gear, in order to avoid jerking and stalling.

To return to automatic driving mode:

- Move the lever to the side to the end position at **D**.

Kick-down

When the accelerator pedal is pressed all the way to the floor (beyond the position normally regarded as full acceleration) a lower gear is immediately engaged. This is known as kick-down.

If the accelerator is released from the kick-down position, the gearbox automatically changes up.

Kick-down is used when maximum acceleration is needed, such as for overtaking.

Safety function

To prevent overrevving the engine, the gearbox control program has a protective downshift inhibitor which prevents the kick-down function.

Geartronic does not permit downshifting/kick-down which would result in an engine speed high enough to damage the engine. Nothing happens if the driver still tries to shift down in this way at high engine speed – the original gear remains engaged.

When kick-down is activated the car can change one or more gears at a time depending on engine speed. The car changes up when the engine reaches its maximum speed in order to prevent damage to the engine.

Mechanical gear selector inhibitor

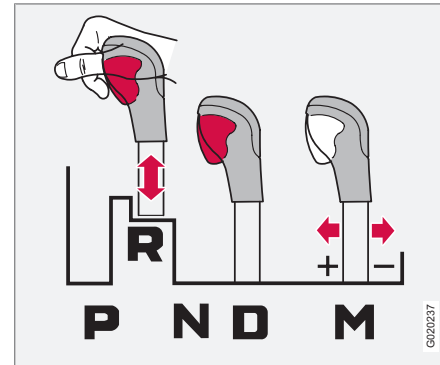

The gear selector can be moved forward and back freely between **N** and **D**. Other positions are locked with a latch that is released with the inhibitor button on the gear selector.

With the inhibitor button depressed the lever can be moved forwards or backwards between **P**, **R**, **N** and **D**.

Automatic gear selector inhibitor

Cars with an automatic gearbox have special safety systems:

Keylock

To remove the remote control key, the gear selector must be in the **P** position. The key is locked in all other positions.

Parking position (P)

Stationary car with engine running:

- Hold your foot on the brake pedal when moving the gear selector to another position.

Electric gear inhibitor – Shiftlock Parking position (P position)

To be able to move the gear selector from the **P** position to other gear positions, the remote control key must be in position **II** and the brake pedal must be depressed.

Shiftlock – Neutral (N position)

If the gear selector is in the **N** position and the car has been stationary for at least three seconds (irrespective of whether the engine is running) then the gear selector is locked in the **N** position.

To be able to move the gear selector from the **N** position to another gear position, the brake pedal must be depressed and the remote control key must be in position **II**.



Automatic gearbox

Disengaging the gear selector inhibitor

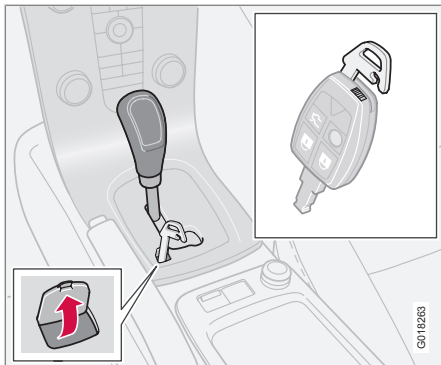

In certain cases, it may be necessary to move the car when it is not driveable, for example if the battery is flat. Proceed as follows to move the car:

1. There is a small cover behind **P-R-N-D** on the gear selector panel. Open it at the rear edge.
2. Fully insert the key blade from the remote control key.
3. Hold the key blade down and at the same time move the gear lever out of the **P** position.

Cold start

When starting in low temperatures, the gear changes can sometimes feel hard. This is due to the gearbox oil's viscosity at low temperatures. To reduce engine emissions, the gearbox shifts up later than normal when the engine is started at low temperatures.

NOTE

Depending on the engine temperature when the engine is started, the idle speed after a cold start may be higher than normal for certain engine types.

Automatic gearbox Powershift*

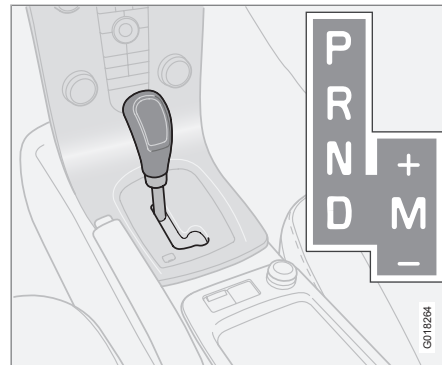

D: Automatic gear positions. **M (+/-):** Manual gear positions.

Powershift is a six-stage automatic gearbox that has double mechanical clutch discs in contrast to a conventional automatic gearbox. A conventional automatic gearbox has a hydraulic torque converter instead that transfers power from engine to gearbox.

Powershift transmission operates in the same way and has similar controls and functions as the Geartronic automatic transmission, described in the previous section.

In the event of uncertainty as to whether or not the car is equipped with Powershift transmission, this can be verified by checking the des-



Automatic gearbox

ignation on the decal number (5) under the bonnet - see page 284. The designation "MPS6" means that it is Powershift transmission - otherwise it is Geartronic automatic transmission.

To bear in mind

The transmission's double clutch has overload protection that is activated if it becomes too hot, e.g. if the car is held stationary with the accelerator pedal on an uphill gradient for a long time.

Overheated transmission causes the car to shake and vibrate, and the warning symbol illuminates and the information display shows a message. The transmission can also overheat during slow driving in queues (10 km/h or

slower) on an uphill gradient, or with a trailer hitched. The transmission cools down when the car is stationary, with foot brake depressed and the engine running at idling speed.

Overheating during slow driving in queues can be avoided by driving in stages: Stop the car and wait with your foot on the brake pedal until there is a moderate distance to the traffic ahead, drive forward a short distance, and then wait another moment with your foot on the brake pedal.



IMPORTANT

Use the foot brake to hold the car stationary on an uphill gradient - do not hold the car with the accelerator pedal. The gearbox could then overheat.

For important information regarding Powershift transmission and towing - see page 174.

Text message and action

In some situations the display can show a message at the same time as a symbol is illuminated.

The table shows three steps with an increased degree of seriousness should the gearbox become too hot. In parallel with the display text the driver is also advised that the car's electronics are temporarily changing the driving characteristics. Follow the instructions on the information display where appropriate.



Automatic gearbox

Symbol	Display	Driving characteristics	Action
	TRANSM. OVERHEAT BRAKE TO HOLD	Difficulty in maintaining even speed at constant engine speed.	Gearbox overheated. Keep the car stationary using the foot brake ^A .
	TRANSM. OVERHEAT PARK SAFELY	Significant pulling in the car's traction.	Gearbox overheated. Park the car immediately in a safe manner.
	TRANSM. COOLING LET ENGINE RUN	No drive due to overheated gearbox.	Gearbox overheated. For fastest cooling: Run the engine at idling speed with the gear lever in the N or P position until the message clears.

^A For fastest cooling: run the engine at idling speed with the gear lever in the **N** or **P** position, until the message clears.

NOTE

The table's examples are no indication that the car is defective but instead show that a safety function has been activated intentionally to prevent damage to one of the car's components.

WARNING

If a warning symbol combined with the text **TRANSM. OVERHEAT PARK SAFELY** is ignored then the heat in the gearbox may become so high that the power transmission between engine and gearbox is temporarily halted in order to prevent the clutch from malfunctioning - the car then loses drive and is stationary until gearbox temperature has cooled to an acceptable level.

For more possible display messages with their respective proposals for solutions concerning automatic transmission, see page 52.

A display text clears automatically after the action has been carried out or after one press on the indicator stalk **READ** button.



DRIVE Start-Stop*

General

Quieter and cleaner



Environmental care is one of Volvo Car Corporation's core values which guides all our activities. This target orientation has resulted in the vehicle series DRIVe, the concept of which involves the interaction of several separate energy-saving functions, with the collective task of reducing fuel consumption, which in turn helps to reduce exhaust emissions.

Start/Stop



In addition to being equipped with a reliable and fuel-efficient diesel engine, this car's engine is equipped with a Start and Stop function which comes into action in the event of e.g. stationary traffic queues or waiting at traffic lights - see the detailed description on the next page.

The engine's automatic restart sequence runs so smoothly that it is hardly noticeable that the engine has actually been switched off. The experience is that the engine has been running the whole time but with an extremely quiet and low idling speed.

The Start/Stop function gives the driver the opportunity for a more active environmentally conscious driving style by means of being able to disengage gear and letting the engine auto-stop, whenever appropriate.

Smart charging

The car's kinetic energy is used during engine braking by means of it being converted into electricity and stored in the car's battery.

Adapted power steering

Another DRIVe function is that the power steering's energy take-off is adapted according to requirements. By means of optimisation and the introduction of an energy saving function the energy take-off can be minimised on occasions where power assistance (help in turning the steering wheel) is not necessary.

Aerodynamics

The DRIVe concept also includes a lowered chassis, front and rear spoilers with low wind resistance, as well as specially developed wheel rims¹.

¹ The range varies depending on the market.



DRIVE Start-Stop*

Function and operation

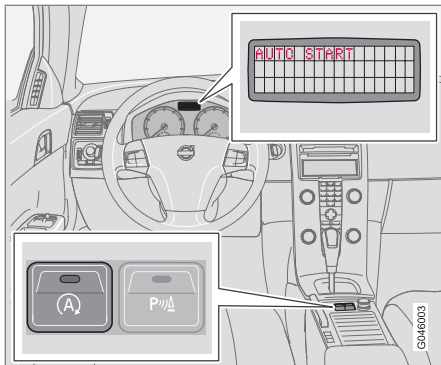

On/Off button and display text **AUTO START-STOP ON**.

The Start/Stop system is activated automatically when the engine is started with the key. The driver is made aware of this function by means of the On/Off button's green lamp being illuminated.

NOTE

After starting with the key and each auto-stop the car must first reach 5 km/h before the automatic Start/Stop function is re-activated - following which certain conditions must also be fulfilled, refer to these under the heading "The engine does not auto-stop".

All the car's normal systems such as lighting, radio etc. work normally even when the engine has been stopped automatically, except that some equipment may have its function temporarily reduced, e.g. climate control fan speed or extremely high audio system volume.

Engine auto-stop

In order for the engine to stop automatically the car must be stationary - however, the Start/Stop function does accept slow rolling, the equivalent to normal walking pace:

- Set the gear lever in neutral position and release the clutch pedal - the engine stops automatically.



The display text **ENGINE IN AUTO START**, and the button's illuminated green lamp, reminds - and indicates - that the engine has been auto-stopped.

Engine auto-start

With the gear lever in neutral position:

- Depress the clutch pedal - the engine starts automatically.
- or
- Depress the accelerator pedal - the engine starts automatically.

On a downhill gradient there is also the option to start the engine automatically as follows:

- Release the foot brake and allow the car to move off - the engine starts automatically when the speed exceeds normal walking pace.

After starting the engine:

- Engage a suitable gear and continue the journey.

Gear indicator

An essential detail in connection with environmental driving is to drive in the right gear and to change gear in time.

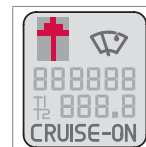

The driver is assisted by an indicator which notifies the driver when it is most advantageous to engage the next higher or lower gear - GSI (Gear Shift Indicator).



DRIVE Start-Stop*

Indication is made with an up or down arrow in the combined instrument panel's lower display.

Deactivate the Start/Stop function

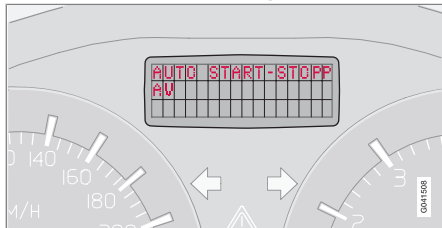

The information display shows here that the Start/Stop function has been disengaged.



In certain situations, it may be advisable to temporarily switch off the automatic Start/Stop function - this is carried out by pressing this button once, at which point the button's lamp goes out.

Disengaged Start/Stop function is indicated by a message appearing on the information display for about 5 seconds.

The Start/Stop function is disengaged until it is reactivated with the button or until the next time the engine is started with the key.

Limitations

The engine does not auto-stop

Although the Start/Stop function is activated, the engine does not stop automatically if:

- the driver has unbuckled the seatbelt.
- the car has not stopped completely.
- the car has been reversed and reverse gear is disengaged.
- the engine does not have normal operating temperature.
- outside temperature is below freezing point or above approx. 30 °C.
- the environment in the passenger compartment differs from the preset values - indicated by the ventilation fan running at a high speed.
- battery capacity is below the minimum permitted level.
- battery temperature is below freezing point or above approx. 55 °C.

The engine auto-starts without driver intervention

An auto-stopped engine may restart in some cases without the driver having decided that the journey should continue. In the following cases the engine auto-starts even if the driver has not depressed the clutch pedal in order to engage a gear:

- The driver's seatbelt buckle is opened.
- Misting forms on the windows.
- The outside temperature is below freezing point or above approx. 30 °C.
- There is a temporarily high current take-off or battery capacity drops below the minimum permitted level.
- The car starts to roll - faster than the equivalent normal walking pace.
- Repeated pumping of the brake pedal.



WARNING

Do not open the bonnet when the engine has stopped automatically - the engine may suddenly start automatically. In order to avoid starting automatically with raised bonnet:

- Engage a gear and apply the parking brake.

The engine does not auto-start

In the following cases the engine does not auto-start after having auto-stopped:

- The driver's seatbelt buckle has been opened - a display text prompts the driver to start the engine normally.
- A gear is engaged without declutching - a display text prompts the driver to set the



DRIVE Start-Stop*

gear lever in neutral position in order to enable auto-start.

Involuntary engine stop

In the event that a start-up fails and the engine stops, proceed as follows:

1. Depress the clutch pedal again - the engine starts automatically after the gear lever has been set in neutral position. Prior to this the information display showed the text **PUT GEAR IN NEUTRAL TO START**.

Text message



In combination with this indicator lamp the Start/Stop function may display text messages on the information display for certain situations. A recommended action

should be performed for some of them. The following table shows some examples.

Message	
AUTO START-STOP ON	Illuminates for about 5 seconds after Start/Stop has been activated.
AUTO START-STOP OFF	Illuminates for about 5 seconds after Start/Stop has been switched off.

Message	
TURN KEY TO START	The engine will not auto-start ^A - perform a normal start using the key.
PUT GEAR IN NEUTRAL TO START	Set the gear lever in neutral position ^B .
DEPRESS CLUTCH PEDAL TO START	The engine is ready to auto-start - waiting for declutching.
AUTO START-STOP SERVICE REQUIRED	Start/Stop function disengaged. A workshop should be contacted.

^A Occurs if the seatbelt is unbuckled after the engine has auto-stopped, for example.

^B Occurs if a gear is engaged without declutching after the engine has auto-stopped.

If a message does not go out after performing an action a workshop should be contacted - an authorised Volvo workshop is recommended, which also applies in the event of the need for any other form of technical assistance.

* Option/accessory, for more information, see Introduction.

**Brake system****Brake servo**

If the car is rolling or is being towed with the engine turned off, the brake pedal must be depressed about 5 times harder than when the engine is running. If the brake pedal is depressed when the engine is started, you will feel the pedal drop. This is normal and due to the brake servo becoming active. This may be more noticeable if the car has Emergency Brake Assistance (EBA).

WARNING

The brake servo only works when the engine is running.

NOTE

If braking with the engine switched off, press the brake pedal sharply once, not repeatedly.

Brake circuits

This symbol illuminates if a brake circuit is not working.

If a fault should occur in one of the circuits, it is still possible to brake the car. The brake pedal will travel further and may feel softer than normal. Harder pressure on the pedal is needed to produce the normal braking effect.

Dampness can affect braking characteristics

Brake components become wet when the car is driven in heavy rain, through pools of water or when the car is washed. This may alter brake pad friction characteristics so that there is a delay before braking effect is noticed.

Press the brake pedal lightly from time to time if driving for long stretches in rain or slushy snow, as well as after setting off in very damp or cold weather. This warms up the brake pads and dries off any water. This precaution is also recommended before parking the car for a long period in such weather conditions.

Maintenance

To keep the car as safe and reliable as possible, follow the Volvo service intervals as specified in the Service and Warranty Booklet, see page 218.

IMPORTANT

The wear on the brake system's components must be checked regularly.

Contact a workshop for information about the procedure or engage a workshop to carry out the inspection - an authorised Volvo workshop is recommended.

If the brakes are used heavily

When driving in the Alps or other roads with similar characteristics, the car's brakes are heavily loaded even if the brake pedal is not being depressed especially hard.

Because speed is often low, the brakes are not cooled as effectively as when driving on flat roads at higher speed.

So as not to overload the brakes, shift down when driving downhill instead of using the foot brake. Use the same gear driving downhill as you would use driving uphill. This uses engine braking more efficiently so the foot brake is only required for brief periods.

Bear in mind that driving with a trailer puts an additional load on the car's brakes.

Brake system

Anti-lock braking system - ABS



The anti-lock braking system (ABS) prevents the wheels from locking up during braking.

This means the ability to steer is maintained and it is easier to swerve to avoid a hazard for example.

After the engine has been started, the ABS will perform a brief self-test at a speed of about 20 km/h. This can be felt and heard as pulses in the brake pedal.

To get the most out of the ABS:

1. Depress the brake pedal with full force. Pulses will be felt.
2. Steer the car in the direction of travel. Do not release the pressure on the pedal.

Practice braking with the ABS system in a traffic-free area and in different weather conditions.

Emergency Brake Assistance – EBA

For sudden braking, EBA (Emergency Brake Assist) provides full-strength braking instantaneously. The EBA function senses when heavy braking is underway by registering how quickly the brake pedal is depressed.

Continue braking without easing off on the brake pedal. The function disengages when the pressure on the brake pedal eases.

This function is always active. It cannot be disengaged.

WARNING

If the BRAKE and ABS warning symbols illuminate at the same time, there may be a fault in the brake system. If the level in the brake fluid reservoir is normal at this stage, drive carefully to the nearest workshop and have the brake system checked - an authorised Volvo workshop is recommended.

If the brake fluid is under the **MIN** level in the brake fluid reservoir, do not drive further before topping up the brake fluid.

The reason for the loss of brake fluid must be investigated.

NOTE

When EBA is activated the brake pedal lowers slightly more than usual, depress (hold) the brake pedal as long as necessary. If the brake pedal is released then all braking ceases.

Emergency brake lights and automatic hazard warning flashers

Emergency brake lights are activated to alert vehicles behind about sudden braking. The function means that the brake light flashes instead of - as in normal braking - shining with a constant glow.

Emergency brake lights are activated at speeds above 50 km/h if the ABS system is working and/or in the event of sudden braking. After the car's speed has been slowed below 10 km/h the brake light returns from flashing to the normal constant glow - while at the same time the hazard warning flashers are activated, and they flash until the driver changes engine speed with the accelerator pedal or they are deactivated with their button, see page 70.



DSTC – Stability and traction control system*

General

The stability and traction control system, DSTC (Dynamic Stability and Traction Control) helps the driver to avoid skidding and improves the car's traction.

A pulsing sound may be noticed during braking or acceleration when the system is in action. The car may accelerate slower than expected when the accelerator pedal is depressed.

Active Yaw Control

The function limits the driving and brake force of the wheels individually in order to stabilise the car.

Spin Control

The function prevents the driving wheels from spinning against the road surface during acceleration.

Traction control system

The function is active at low speed and transfers power from the driving wheel that is spinning to the one that is not.

Reduced operation

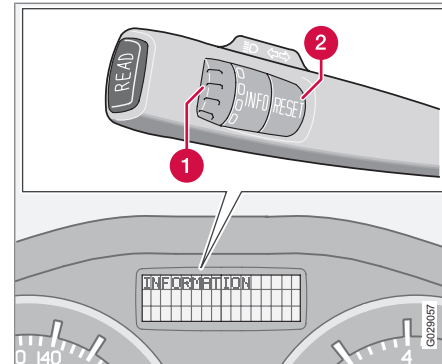

Controls and information display.

- 1 Thumbwheel¹
- 2 **RESET** button¹

The stability system is activated automatically each time the car is started.

System operation during skidding and acceleration can be partially deactivated. Operation during skidding is then delayed and so allows more skidding which provides greater freedom for dynamic driving. Traction in deep snow or sand is improved at the same time as acceleration is no longer limited.

Operation

1. Turn the thumbwheel until the DSTC menu appears.

DSTC ON means that the system function is unchanged.

DSTC SPIN CONTROL OFF means that system operation is reduced.

2. Press and hold the **RESET** button until the DSTC menu is changed.

The system remains reduced until the driver reactivates it or until the engine is switched off - after the engine is started the next time DSTC is back in its normal mode again.

WARNING

Suppressing system function may alter the driving characteristics of the car.

NOTE

DSTC ON is shown for several seconds on the display each time the engine is started.

¹ No function in cars without trip computer, fuel-driven parking heater as well as stability and traction control system.



DSTC – Stability and traction control system*

Messages on the information display

TRACTION CONTROL TEMPORARILY

OFF means that the system has been temporarily reduced due to excessive brake temperature.

- The function is reactivated automatically when the brakes have cooled.

ANTI-SKID SERVICE REQUIRED system disabled due to a fault.

- Stop the car in a safe place and turn off the engine.
 - > If the message remains when the engine is restarted, drive to a workshop. An authorised Volvo workshop is recommended.

If the symbols  and  are displayed at the same time:

- Read the message on the information display.

If the symbol  appears alone then it may appear as follows:

- Flashing light means that the DSTC system is now being activated.
- Constant glow for 2 seconds means system check when the engine is started.
- Constant glow after starting the engine or while driving means that there is a fault in the DSTC system.

Symbols in the combined instrument panel



DSTC system



Information



Park Assist*

General information on parking assistance

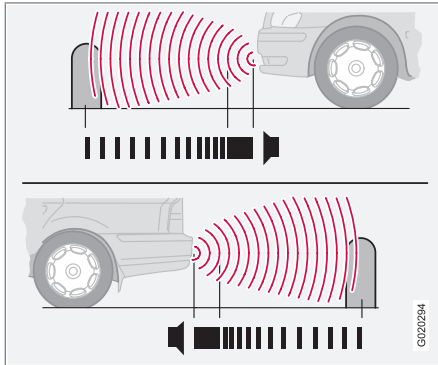

Parking assistance front and rear.

Parking assistance is used as an aid to parking. A signal indicates the distance to a detected obstacle.

! WARNING

Parking assistance does not relinquish the driver's own responsibility during parking. The sensors have blind spots where obstacles cannot be detected. Be aware of children or animals near the car.

Variants

Parking assistance is available in two variants:

- Rear only.
- Both front and rear.

Function

The frequency of the signal increases the shorter the distance to an obstacle, in front of or behind the car. If the volume of another audio source from the audio system is high, then this is automatically lowered.

The tone becomes constant at a distance of about 30 cm. If there are obstacles within this distance both behind and in front of the car, the signal alternates between left and right-hand speakers.

Rear parking assistance only

The system is automatically engaged when the car is started.

Rear parking assistance is activated when reverse gear is engaged and the message **Park Assist active EXIT to deactivate** is shown on the audio system's display.

If the system is switched off, the display shows **Park Assist deactivated ENTER to activate** as soon as reverse gear is engaged. To change the settings, see page 81.

The distance covered behind the car is about 1.5 metres. The signal comes from the rear loudspeakers.

Limitations

The system must be deactivated when reversing with a trailer, or bike carrier on the towbar or similar. Otherwise the trailer or bike carrier would trigger the sensors.

i NOTE

Rear parking assistance is deactivated automatically when towing a trailer if a Volvo genuine trailer cable is used.

Parking assistance both front and rear

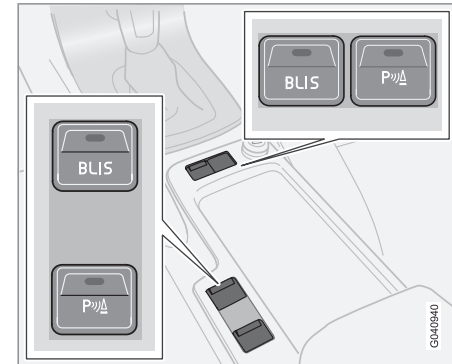

Button for Off/On (button location depends on other selected equipment).



Park Assist*

The system is automatically engaged when the car is started and the switch's On/Off lamp is illuminated. If parking assistance is switched off with the button, the lamp goes out.

Front

Front parking assistance is active at speeds below 15 km/h. The system is deactivated at higher speeds. When the speed is below 10 km/h the system is reactivated.

The distance covered to the front of the car is about 0.8 metres. The signal for obstacles in front comes from the front loudspeakers.

Limitations

Front parking assistance cannot be combined with extra lights because the sensors are affected by the extra lights.

Rear

Rear parking assistance is activated when reverse gear is engaged.

The distance covered to the rear of the car is about 1.5 metres. The signal for obstacles behind comes from the rear loudspeakers.

Limitations

See the previous section Rear parking assistance only.

Fault indicator



If the information symbol illuminates with constant glow and the display shows **PARK ASSIST SERVICE REQUIRED** then parking assistance is disengaged. For attention, contact a workshop - an authorised Volvo workshop is recommended.



IMPORTANT

In certain conditions the parking assistance system may produce incorrect warning signals that are caused by external sound sources that emit the same ultrasonic frequencies that the system works with.

Examples of such sources include horns, wet tyres on asphalt, pneumatic brakes and exhaust noises from motorcycles etc.

Cleaning the sensors

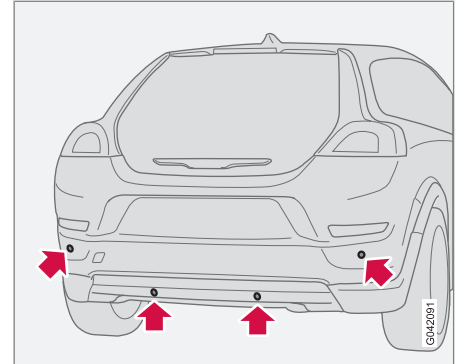

Parking assistance sensors.

The sensors must be cleaned regularly to ensure that they work properly. Clean them with water and car shampoo.



NOTE

Dirt, ice and snow covering the sensors may cause incorrect warning signals.



General

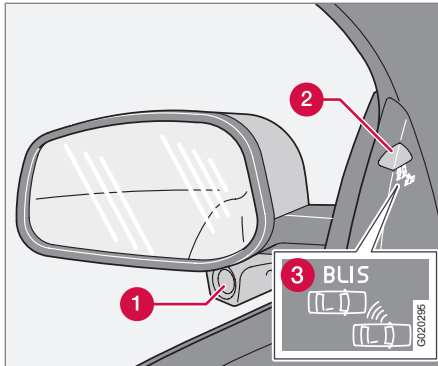

Rearview mirror with BLIS system.

- 1 BLIS camera
- 2 Indicator lamp
- 3 BLIS symbol

WARNING

The system is a supplement to, not a replacement for, a safe driving style and use of the rearview mirrors. It can never replace the driver's attention and responsibility. The responsibility for changing lanes safely always rests with the driver.

BLIS (Blind Spot Information System) is an information system that under certain conditions can help to draw the driver's attention to vehicles moving in the same direction in the so-called "blind spot".

The system is designed to work most effectively when driving in dense traffic on multi-lane highways.

BLIS is based on camera technology. The cameras (1) are located under the door mirrors.

When a camera has detected a vehicle inside the blind spot zone the indicator lamp (2) illuminates with a constant glow.

NOTE

The lamp illuminates on the side of the car where the system has detected the vehicle. If the car is overtaken on both sides at the same time then both lamps illuminate.

BLIS advises the driver with a message if a fault arises in the system. If for example the system's cameras are obscured then the BLIS indicator lamp flashes and a message is shown in the information display. In such cases, check and clean the lenses. If necessary, the system can be switched off temporarily by pressing the **BLIS** button see page 172.

Blind spots

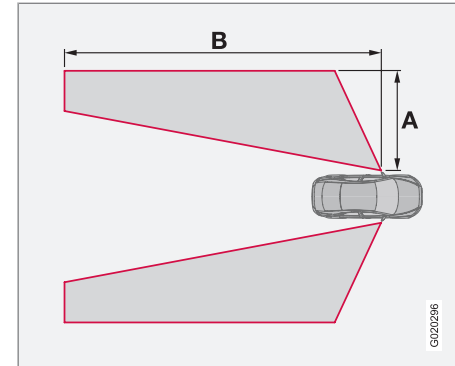

A = approx. 3.0 m, B = approx. 9.5 m.

When BLIS operates

The system operates when the car is driven at a speed above 10 km/h.

Overtaking

The system is designed to react if you overtake another vehicle at a speed of up to 10 km/h faster than the other vehicle.

The system is designed to react if you are overtaken by a vehicle travelling up to 70 km/h faster than your vehicle.



BLIS*

WARNING

BLIS does not work in sharp bends.

BLIS does not work when the car is reversing.

A wide trailer coupled to the car can conceal other vehicles in adjacent lanes. It can prevent the vehicle in the screened area from being detected by BLIS.

Daylight and darkness

In daylight the system reacts to the shape of the surrounding vehicles. The system is designed to detect motor vehicles such as cars, trucks, buses and motorcycles.

In darkness the system reacts to the headlamps of surrounding vehicles. Vehicles with headlamps that are switched off are not detected by the system. This means for example that the system does not react to a trailer without headlamps which is towed behind a car or truck.

WARNING

The system does not react to cyclists or moped riders.

The BLIS cameras have limitations similar to those of the human eye, i.e. they do not see as well in e.g. heavy snowfall, strong oncoming light or thick fog.

Activate/deactivate

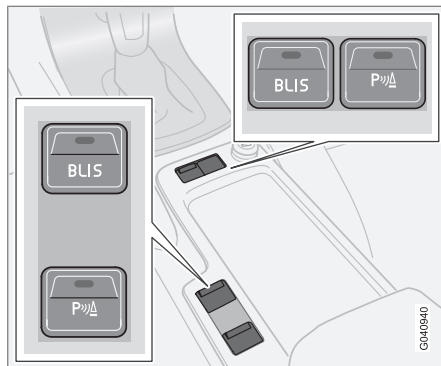

Button for Off/On (button location depends on other selected equipment).

BLIS is activated when the engine is started. The indicator lamps in the door panels flash three times when BLIS is activated.

The system can be deactivated/activated by pressing the **BLIS** button.

When BLIS is deactivated the light in the button goes out and a text message is shown on the instrument panel display.

When BLIS is activated the light in the button illuminates, a new text message is shown on the display and the indicator lamps in the door panels flash three times. Press the **READ** but-

ton to clear the text message. For more information on messages, see page 52.

BLIS system message

Text on the display	Specification
BLIS ON	The BLIS system is activated.
BLIS REDUCED FUNCTION	Reduced function in data transmission between the BLIS system's camera and the car's electrical system. The camera resets itself when the data transmission between the BLIS system's camera and the car's electrical system returns to normal.
BLIS CAMERA BLOCKED	One or both cameras blocked - clean the lenses.



BLIS*

Text on the display	Specification
BLIS SERVICE REQUIRED	Blind spot syst. disengaged - contact a workshop.
BLIS OFF	The BLIS system is deactivated.

! **IMPORTANT**

Repair of the BLIS system components must only be performed by a workshop - an authorised Volvo workshop is recommended.

Cleaning

In order to work most effectively the BLIS camera lenses must be clean. The lenses can be cleaned with a soft cloth or damp sponge. Clean the lenses carefully so that they are not scratched.

! **IMPORTANT**

The lenses are electrically heated to melt ice or snow. If necessary, brush snow away from the lenses.

Limitations

In some situations the BLIS indicator lamp may illuminate despite there being no other vehicle within the blind spot.

i **NOTE**

If the BLIS indicator lamp illuminates on isolated occasions despite there being no other vehicle within the blind spot then this does not mean that a fault has arisen in the system.

In the event of a fault in the BLIS system the display shows the text **BLIS SERVICE REQUIRED**.

Here are several examples of situations where the BLIS indicator lamp may illuminate even if there is no other vehicle within the blind spot.

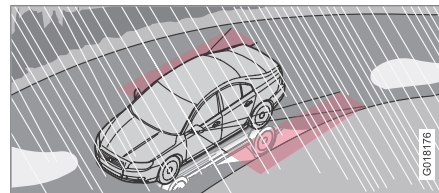

Reflection from shiny wet road surface.

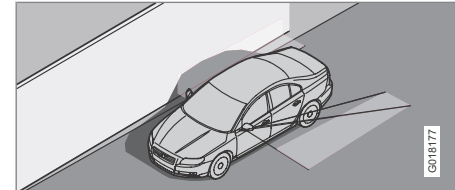

Own shadow on large, light, smooth surface, e.g. noise barrier or concrete road surface.

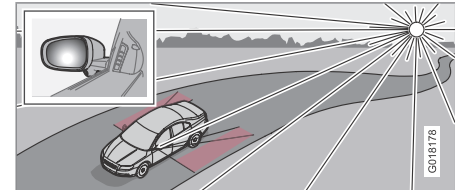

Low sun in the camera.



Towing and recovery

Start assistance

Use a donor battery if the battery is discharged and the engine does not start. Do not tow the car to bump start the engine, see page 178.

IMPORTANT

Bump starting the car can damage the catalytic converter.

Towing

Find out the statutory maximum speed limit for towing before towing begins.

1. Turn the remote control key to position II and unlock the steering lock so that the car can be steered, see page 151.
2. The key must remain in the ignition switch while the car is being towed.
3. Keep the towline taut when the towing vehicle reduces speed by holding your foot gently pressed on the brake pedal - thereby avoiding unnecessary jerking.
4. Be prepared to brake to stop.

WARNING

- The steering lock must be unlocked before towing - the lock stays in the position it was in when the voltage was disconnected.
- The remote control key must be in key position II - in position I all airbags are deactivated.
- Never remove the key from the ignition switch when the car is being towed.

NOTE

If the car is de-energised then the steering lock must be unlocked using a donor battery before towing can be started.

WARNING

The brake servo and power steering do not work when the engine is switched off. The brake pedal must be pressed about five times harder than normal, and the steering will be considerably heavier than normal.

Manual gearbox

Prior to towing:

- Move gear lever into neutral and release the parking brake.

Automatic gearbox Geartronic

Prior to towing:

- Move the gear selector to position N and release the parking brake.

IMPORTANT

Note that the car must always be towed with the wheels rolling forward.

- Cars with automatic gearbox must not be towed at speeds above 80 km/h or further than 80 km.

Automatic gearbox Powershift

The model with Powershift transmission should not be towed as it is dependent on the engine running in order to receive sufficient lubrication. If towing still has to take place, the route must be as short as possible and then with very low speed.

In the event of uncertainty as to whether or not the car is equipped with Powershift transmission, this can be verified by checking the designation on the decal number (5) under the bonnet - see page 284. The designation "MPS6" means that it is Powershift transmission - otherwise it is Geartronic transmission.

**Towing and recovery** **IMPORTANT**

Avoid towing.

- However, the car can be towed for a short distance at low speed to move it from a dangerous position - not further than 10 km and not faster than 10 km/h. Note that the car must always be towed with the wheels rolling forward.
- In the event of moving a longer distance than 10 km, the car must be transported with the drive wheels raised from the road - professional recovery is recommended.

Prior to towing:

- Move the gear selector to position **N** and release the parking brake.



Towing and recovery

Towing eye

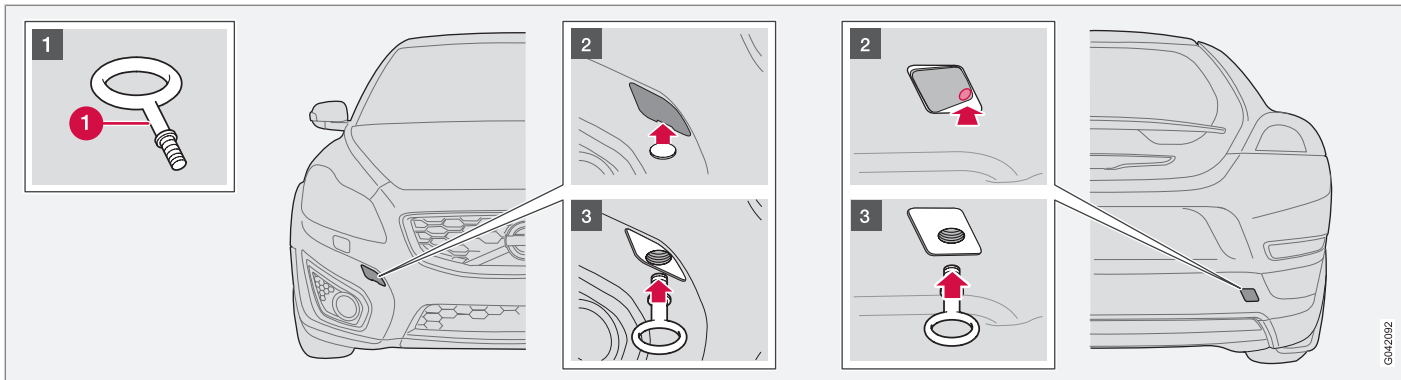

GA-2002

The towing eye is screwed into a threaded socket behind a cover on the right-hand side of the bumper, front or rear.

Fitting the towing eye

- 1 Take out the towing eye (1) that is located under the floor hatch in the cargo area.
- 2 The cover for the towing eye's attachment point is available in two variants which must be opened in different ways:
 - Open the variant with a recess using a coin or similar inserted in the recess,

turning it outwards. Then turn out the cover completely and remove it.

- The second variant has a marking along one side or in a corner: Press the marking with a finger and fold out the opposite side/corner at the same time using a coin or similar - the cover turns around its axis and can then be removed.
- 3 Screw the towing eye right in up to its flange. Turn in the towing eye firmly e.g. using the wheel wrench.

After use, unscrew the towing eye and return it to its place.

Finish by refitting the cover onto the bumper.

IMPORTANT

The towing eye is only designed for towing on roads - **not** for pulling the car unstuck or out of a ditch. Call a recovery service for recovery assistance.

**Towing and recovery**** NOTE**

On certain cars with fitted towbar the towing eye cannot be secured in the rear mounting. In which case, secure the tow rope in the towbar.

For this reason it is advisable to store the towbar's towball in the car, see page 181.

Recovery

Call a recovery service for recovery assistance.

The car must always be towed with the wheels rolling forward.

 IMPORTANT

Cars with automatic gearbox must only be towed with drive wheels raised from the road.



Start assistance

Starting with a donor battery

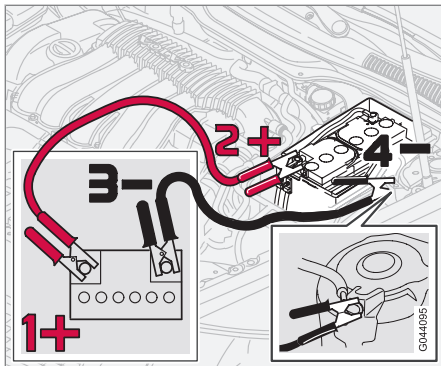

If the battery is flat then the car can be started with current from another battery.

When jump starting the car, the following steps are recommended to avoid short circuits or other damage:

1. Turn the remote control key to key position 0.
2. Check that the donor battery has a voltage of 12 V.
3. If the donor battery is installed in another car - switch off the donor car's engine and make sure that the two cars do not touch each other.

4. Connect one of the red jump lead's clamps to the donor battery's positive terminal (1).

! IMPORTANT

Connect the start cable carefully to avoid short circuits with other components in the engine compartment.

5. Connect the red jump lead's other clamp onto the car's positive terminal (2).
6. Connect one of the black jump lead's clamps to the donor battery's negative terminal (3).
7. Fit the other clamp to a grounding point, such as by the left-hand spring strut (4).
8. Check that the jump lead clamps are affixed securely so that there are no sparks during the starting procedure.
9. Start the engine of the "donor car" and allow it to run a few minutes at a speed slightly higher than idle approx. 1500 rpm.
10. Start the engine in the car with the discharged battery.

! IMPORTANT

Do not touch the crocodile clips during the start procedure. There is a risk of sparks forming.

11. Remove the jump leads in reverse order - first the black and then the red.
 - > Make sure that none of the black jump lead's clamps comes into contact with the battery's positive terminal or the clamp connected to the red jump lead.

! WARNING

- The battery can generate oxyhydrogen gas, which is highly explosive. A spark can be formed if a jump lead is connected incorrectly, and this can be enough for the battery to explode.
- The battery contains sulphuric acid, which can cause serious burns.
- If sulphuric acid comes into contact with eyes, skin or clothing, flush with large quantities of water. If acid splashes into the eyes - seek medical attention immediately.

For more information on the car's battery - see page 230.



Driving with a trailer

General

Payload depends on the car's kerb weight. The total of the weight of the passengers and all accessories, e.g. towbar, reduces the car's payload by a corresponding weight. For more detailed information on weights, see page 287.

If the towing bracket is fitted by an authorised Volvo workshop, then the car is delivered with the necessary equipment for driving with a trailer.

- The car's towing bracket must be of an approved type.
- If the towbar is retrofitted, check with a Volvo dealer that the car is fully equipped for driving with a trailer.
- Distribute the load on the trailer so that the weight on the towing bracket follows the specified maximum towball load.
- Increase the tyre pressure to the recommended pressure for a full load. For tyre pressure decal location, see page 196.
- Clean the towing bracket regularly and grease the towball¹.
- The engine is loaded more heavily than usual when driving with a trailer.

- Do not tow a heavy trailer when the car is brand new. Please wait until it has been driven at least 1000 km.
- The brakes are loaded much more than usual on long and steep downhill slopes. Downshift to a lower gear and adjust your speed.
- Avoid driving with a trailer on inclines of more than 12%.
- For safety reasons, the maximum permitted speed for the car when coupled with a trailer should not be exceeded. Follow the regulations in force for the permitted speeds and weights.
- Maintain a low speed when driving with a trailer up long, steep ascents.

Trailer weights

For information on Volvo's permitted trailer weights, see page 287.

NOTE

The stated maximum permitted trailer weights are those permitted by Volvo. National vehicle regulations can further limit trailer weights and speeds. Towbars can be certified for higher towing weights than the car can actually tow.

WARNING

Follow the stated recommendations for trailer weights. Otherwise, the car and trailer may be difficult to control in the event of sudden movement and braking.

Manual gearbox**Overheating**

When driving with a trailer in hilly terrain in a hot climate there may be a risk of overheating.

- Do not run the engine at higher revolutions than 4500 rpm (diesel engines: 3500 rpm) - otherwise the oil temperature may become too high.

Diesel engine 5-cyl

- If an engine starts to run too hot, the instrument panel will display a text message which recommends switching to a lower gear - follow the recommendation given.
- In the event of a risk of overheating the optimal speed for the engine is 2300-3000 rpm for optimum circulation of the coolant.

¹ Do **not** lubricate the towball if using a stabiliser hitch.



Driving with a trailer

Automatic gearbox

Overheating

When driving with a trailer in hilly terrain in a hot climate there may be a risk of overheating.

- An automatic gearbox selects the optimum gear related to load and engine speed.

Steep inclines

- Do not lock the automatic transmission in a higher gear than the engine "can cope with" - it is not always a good idea to drive at a high gear with low engine revolutions.



IMPORTANT

See also the specific information on slow driving with trailer for cars with the Powershift automatic transmission on page 159.

hitched trailer. Always use the parking brake.

- Block the wheels with chocks when parking a car with hitched trailer on a hill.

Starting on a hill

1. Depress the foot brake.
2. Move the gear selector to driving position **D**.
3. Release the parking brake.
4. Release the foot brake and start driving off.

Parking on a hill

1. Depress the foot brake.
 2. Apply the parking brake.
 3. Move the gear selector to parking position **P**.
 4. Release the foot brake.
- Move the gear selector to park position **P** when parking an automatic car with a



Towing equipment*

Towbar

If the car is equipped with a detachable towbar, the installation instructions for the loose section must be followed carefully, see page 183.

! WARNING

If the car is fitted with a Volvo detachable towbar:

- Follow the installation instructions carefully.
- The detachable section must be locked with the key before setting off.
- Check that the indicator window shows green.

Important checks

- The towbar's towball must be cleaned and greased regularly.

i NOTE

If a towball hitch with vibration damper is used, it is not necessary to grease the towball.

Storing the towbar

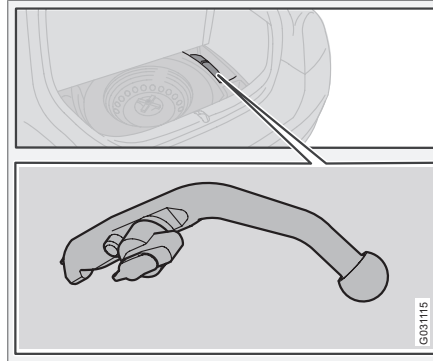

Towbar storage space.

! IMPORTANT

Always remove the towbar after use and store it in the appointed location in the car, firmly fastened with its strap.

Trailer cable

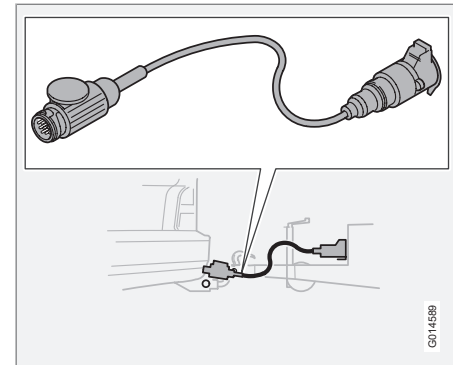

An adapter is required if the car's towing bracket has 13 pin electrics and the trailer has 7 pin electrics. Use an adapter cable approved by Volvo. Make sure the cable does not drag on the ground.



Towing equipment*

Specifications

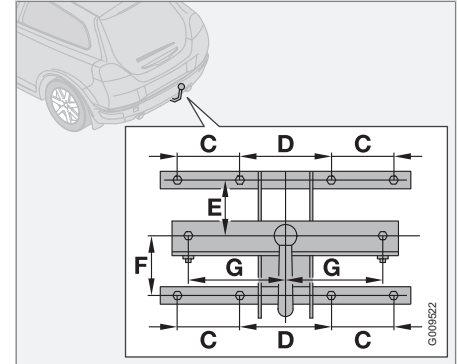
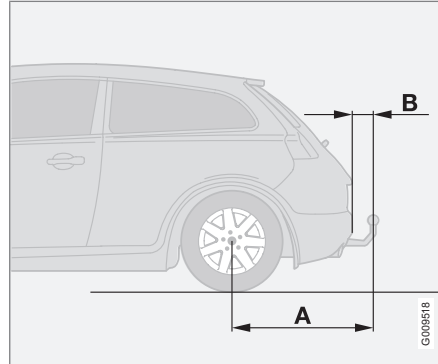
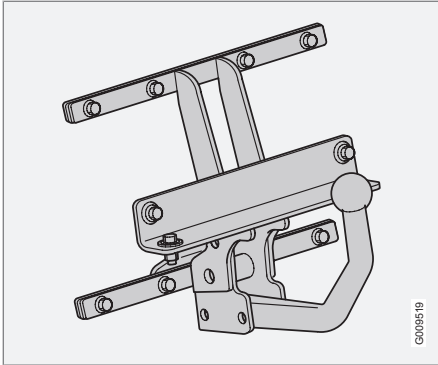

Dimensions for mounting points (mm)

A	B	C	D	E	F	G
854	98	100	140	130	113	150



Detachable towbar*

Fitting the towbar

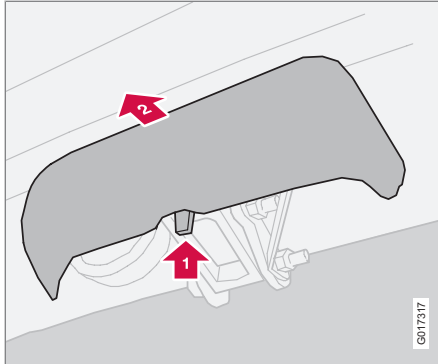

G017317

1. Remove the protective cover by first pressing in the catch **1** and then pulling the cover straight back **2**.

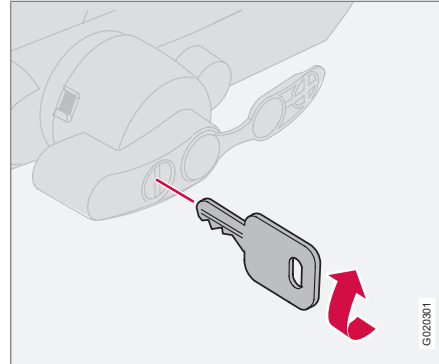

G020301

2. Ensure that the mechanism is in the unlocked position by turning the key clockwise.

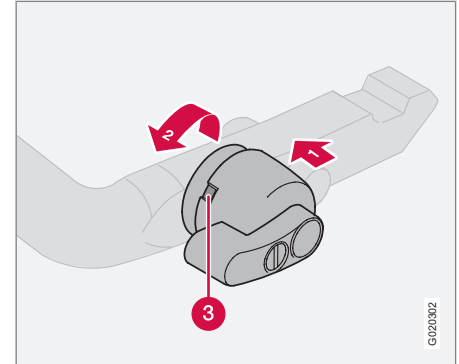

G020302

3. Check that the indicator window (3) shows red. If the window does not show red, press in **1** and turn the locking wheel anti-clockwise **2** until you hear a click.



Detachable towbar*

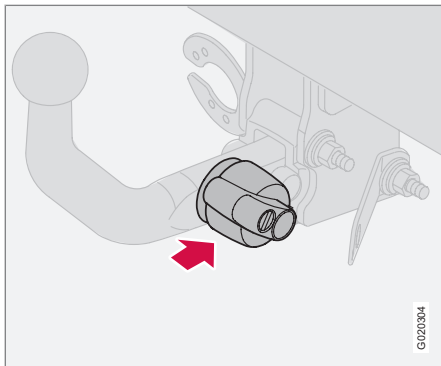

4. Insert the towbar until you hear a click.

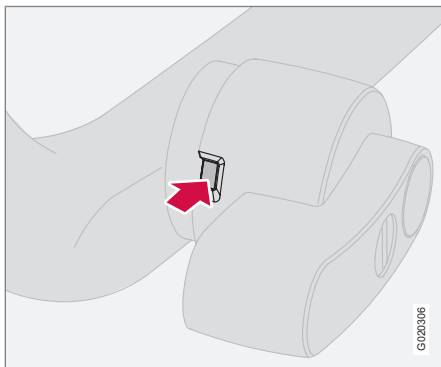

5. Check that the indicator window shows green.

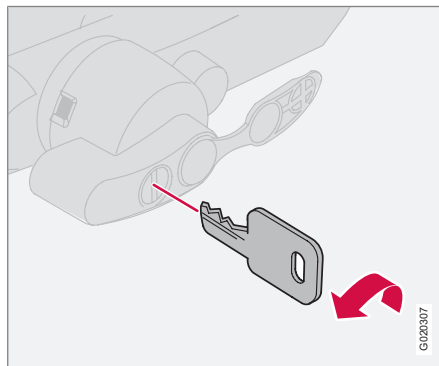

6. Turn the key anticlockwise to locked position. Remove the key from the lock.

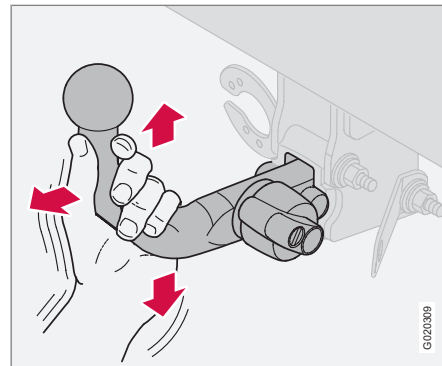

7. Check that the towbar is secure by pulling it up, down and back.

⚠ WARNING

If the towbar is not fitted correctly then it must be detached and reattached in accordance with the previous instructions.

! IMPORTANT

Only grease in the ball for the towing hitch, the remainder of the towbar should be clean and dry.

06



Detachable towbar*

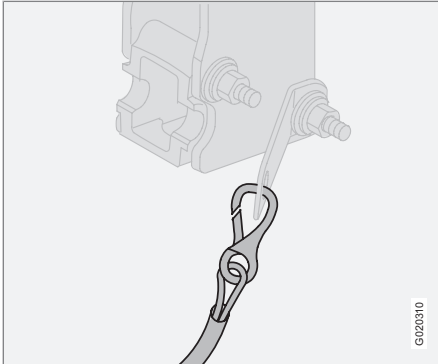

GJ20310

8. Safety cable.

! WARNING

Be sure to attach the trailer's safety cable to the correct place.

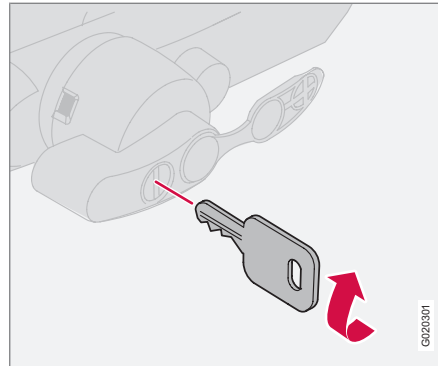
Removing the towbar

GJ20301

1. Insert the key and turn it clockwise to the unlocked position.

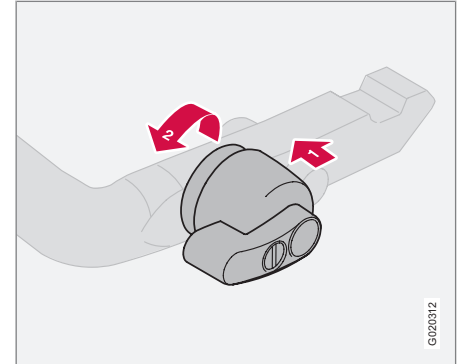

GJ20312

2. Push in the locking wheel **1** and turn it anticlockwise **2** until you hear a click.



Detachable towbar*

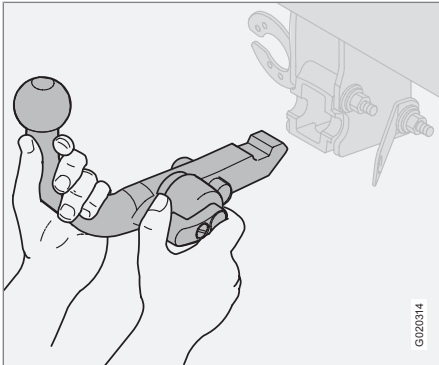

3. Turn the locking wheel down fully, until it comes to a stop. Hold it in this position while pulling the towbar rearward and upward.

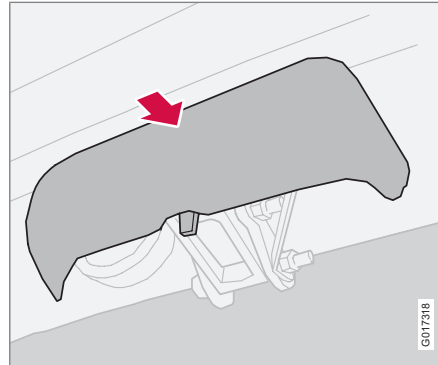

4. Push on the protective cover.

WARNING

Secure the towbar safely if it is stored in the car, see page 181.



Loading

General

Payload depends on the car's kerb weight. The total of the weight of the passengers and all accessories reduces the car's payload by a corresponding weight. For more detailed information on weights, see page 287.

WARNING

The car's driving characteristics change depending on how heavily it is loaded and how the load is distributed.

Loading the cargo area

Stop the engine and apply the parking brake when loading or unloading long objects. The gear lever or gear selector can be knocked out of position by long loads, which could set the car in motion.

To increase the size of the cargo area, the head restraints can be removed and the seats folded down, see page 116.

Place the load firmly against the backrest in front.

- The head rests can be removed so that they are not damaged.
- Put wide loads in the centre.

- Heavy objects should be placed as low as possible. Avoid placing heavy loads on a lowered backrest.
- Cover sharp edges with something soft to avoid damaging the upholstery or the glass surface of the tailgate.
- Secure all loads to the load retaining eye-lets with straps or web lashings.

WARNING

A loose object weighing 20 kg can, in a frontal collision at a speed of 50 km/h, carry the impact of an item weighing 1000 kg.

WARNING

Never load cargo above the backrest.

The protection provided by the inflatable curtain in the headlining may be compromised or eliminated by high loads.

Always secure the load. During heavy braking the load may otherwise shift, causing injury to the car's occupants.

Load carriers*

To avoid damaging the car and for maximum possible safety while driving, it is recommended to use load carriers specially designed for your car by Volvo.

Carefully follow the mounting instructions supplied with the carriers.

- Check periodically that the load carriers and load are properly secured. Lash the load securely with retaining straps.
- Distribute the load evenly over the load carriers. Put the heaviest objects at the bottom.
- The size of the area exposed to the wind, and therefore fuel consumption, increase with the load's size.
- Drive gently. Avoid quick acceleration, heavy braking and hard cornering.

WARNING

The car's centre of gravity and driving characteristics are altered by roof loads.



Adjusting headlamp pattern

Correct light pattern for left or right-hand traffic

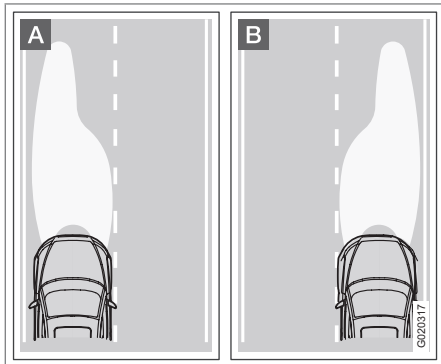

- A** Headlamp pattern for left-hand traffic.
- B** Headlamp pattern for right-hand traffic.

The headlamp pattern can be adjusted using a control in each headlamp housing to avoid dazzling oncoming motorists.

The correct pattern will also better illuminate the verge.

Halogen headlamps

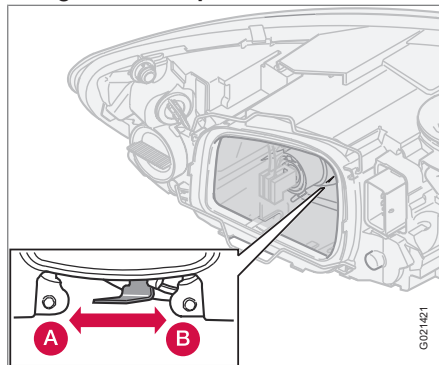

- A** Left-hand traffic.
- B** Right-hand traffic.

Headlamps with Active Bending Lights

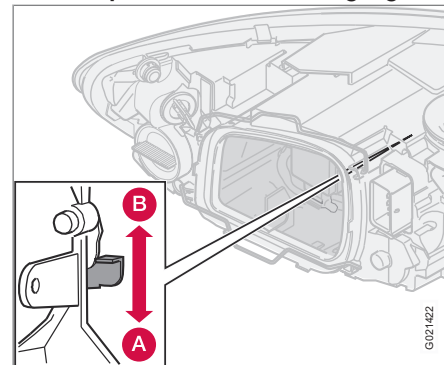

- A** Left-hand traffic.
- B** Right-hand traffic.

⚠ WARNING

On cars with Xenon headlamps, the replacement of Xenon lamps must be carried out at a workshop - an authorised Volvo workshop is recommended. Working with Xenon lamps demands extreme caution because the headlamp is equipped with a high voltage unit.



General.....	192
Tyre pressure.....	196
Warning triangle* and spare wheel *	197
Changing wheels.....	199
Emergency puncture repair*	201

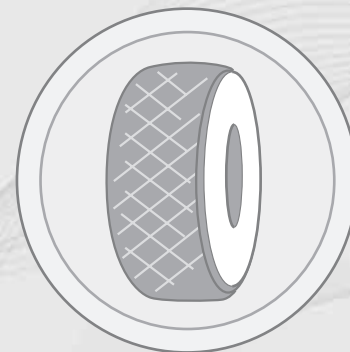

07

WHEELS AND TYRES

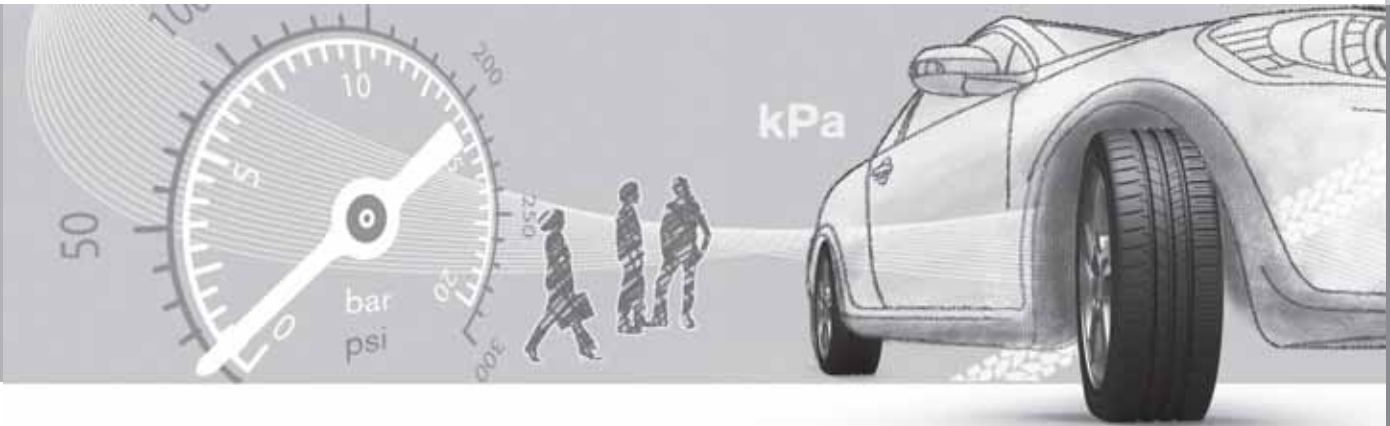



General

Driving characteristics and tyres

The tyres greatly affect the car's driving characteristics. The type of tyre, dimensions, tyre pressure and speed rating are important for how the car performs.

When changing tyres, ensure that tyres of the same type and dimensions, and preferably also the same make, are fitted to all four wheels. Follow the recommended tyre pressures specified on the tyre pressure label, see page 196.

Designation of dimensions

The dimensions are stated on all car tyres. Example: 205/55R16 91 W.

205	Tyre width (mm)
55	Ratio between tyre wall height and tyre width (%)
R	Radial ply
16	Rim diameter in inches (")
91	Tyre load index (in this case 615 kg)
W	Speed rating for maximum permitted speed (in this case 270 km/h)

Speed ratings

The car is approved as a whole, which means that dimensions and speed ratings must not differ from those specified on the vehicle registration document. The only exception to these conditions is winter tyres (both those with metal studs and those without). If such a tyre is chosen, the car must not be driven faster than the speed rating of the tyre (for example, class Q can be driven at a maximum of 160 km/h).

Remember that traffic regulations determine how fast a car can be driven, not the speed class of the tyres.

Note! Maximum permitted speeds indicated.

Q	160 km/h (used only on winter tyres)
T	190 km/h
H	210 km/h
V	240 km/h
W	270 km/h
Y	300 km/h

New tyres

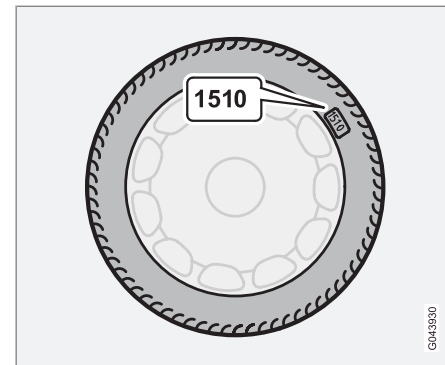

Tyres are perishable. After a few years they begin to harden at the same time as the friction capacity/characteristics gradually deteriorate. For this reason, aim to get as fresh tyres as possible when you replace them. This is especially important with regard to winter tyres. The last four digits in the sequence mean the week and year of manufacture. This is the tyre's DOT marking (Department of Transportation), and this is stated with four digits, for example 1510. The tyre in the illustration was manufactured in week 15 of 2010.

Tyre age

All tyres older than six years should be checked by an expert even if they seem undamaged.

GP43830



General

The reason for this is that tyres age and decompose, even if they are hardly ever or never used. The function can therefore be affected due to the tyre's constituent materials being broken down. In such a case the tyre should then not be used. This also applies to spare tyres, winter tyres and tyres saved for future use. Examples of external signs which indicate that the tyre is unsuitable for use are cracks or discoloration.

The age of the tyre can be determined by the DOT marking, see previous illustration.

More even wear and maintenance

The correct tyre pressure results in more even wear, see page 196. Driving style, tyre pressure, climate and road condition affect how quickly your tyres age and wear. To avoid differences in tread depth and to prevent wear patterns arising, the front and rear wheels can be switched with each other. A suitable distance for the first change is approx. 5000 km and then at 10 000 km intervals. Volvo recommends that you contact an authorised Volvo workshop for checking if you are uncertain about tread depth. If significant differences in wear (>1 mm difference in tread depth) between tyres have already occurred, the least worn tyres must always be placed on the rear. Understeer is normally easier to correct than oversteer, and leads to the car continuing for-

wards in a straight line rather than having the rear end skidding to one side, resulting in possible complete loss of control over the car. This is why it is important for the rear wheels never to lose grip before the front wheels.

Wheels should be stored lying down or hanging up, and not standing up.

Tyres with tread wear indicators

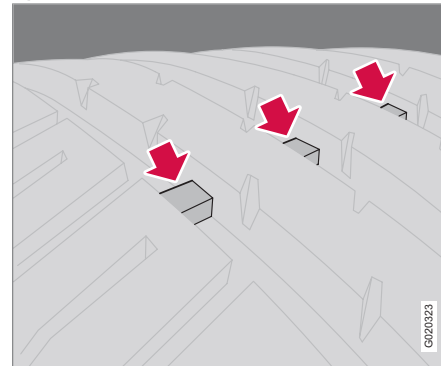

Tread wear indicators.

Tread wear indicators are narrow treadless bands across the width of the tread. On the side of the tyre are the letters TWI (Tread Wear Indicator). When the tyre's tread depth is down to 1.6 mm, the tread depth will be level in height with the tread wear indicators. Change to new tyres as soon as possible. Remember that

tyres with little tread depth provide very poor grip in rain and snow.

Winter tyres

Volvo recommends winter tyres with specific winter tyre dimensions. Tyre dimensions are dependent on engine variant. When driving on winter tyres, they must be fitted to all four wheels.

i NOTE

Volvo recommends that you consult a Volvo dealer about which wheel rim and tyre types are most suitable.

Studded tyres

Studded winter tyres should be run in gently for 500-1000 km, so that the studs settle properly into the tyres. This gives the tyre, and especially the studs, a longer service life.

i NOTE

The legal provisions for the use of studded tyres vary from country to country.

Tread depth

Road conditions with ice, slush and low temperatures place considerably higher demands on tyres than summer conditions. It is therefore



General

recommended not to drive on winter tyres that have a tread depth of less than 4 mm.

Snow chains

Snow chains may only be used on the front wheels. This also applies to all-wheel-drive cars.

Never drive faster than 50 km/h with snow chains. Avoid driving on bare ground as this wears out both the snow chains and tyres.

WARNING

Use Volvo genuine snow chains or equivalent chains designed for the car model, and tyre and rim dimensions. In the event of uncertainty Volvo recommends that you consult an authorised Volvo workshop. The wrong snow chains may cause serious damage to your car and lead to an accident.

Rims and wheel nuts

Only use wheel rims that are tested and approved by Volvo and which are included in the Volvo genuine accessories range.

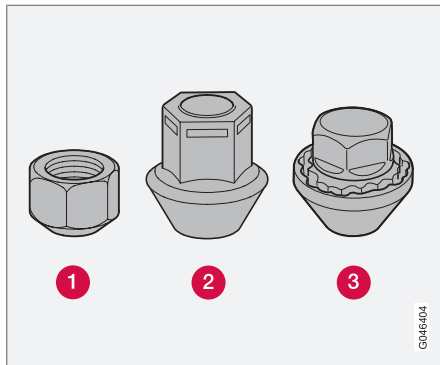

- 1** Standard wheel nuts - tightening torque: 110 Nm
- 2** Bulge acorn wheel nuts - tightening torque: 130 Nm
- 3** Locking wheel nuts - tightening torque: 110 Nm

There are three different models of wheel nut.

1. Tighten the wheel nuts.
2. Check the torque with a torque wrench.

IMPORTANT

Overtightening can damage the nuts and the bolts.

Steel rims – standard wheel nuts (1)

Steel rims are normally mounted with the standard wheel nuts, but the bulge acorn variety may also be used.

WARNING

Never use standard nuts for aluminium rims. The wheel could come loose.

Aluminium rims – bulge acorn wheel nuts (2)

Only use the bulge acorn variety of nuts with aluminium rims.

NOTE

These nuts may also be used with steel rims.

Locking wheel nuts (3)

Locking wheel nuts can be used on both aluminium and steel rims. If steel rims with locking wheel nuts are used in combination with wheel covers, the locking wheel nut should be mounted on the bolt nearest the air valve. Otherwise the wheel cover cannot be fitted to the rim.



General

Spare wheel Temporary Spare*

The spare wheel (Temporary spare) is only intended for use temporarily and must be replaced by an ordinary wheel as soon as possible. The car's handling may be altered by the use of the spare wheel. The spare wheel is smaller than the normal wheel. The car's ground clearance is affected accordingly. Pay attention to high kerbs and do not machine wash the car. If the spare wheel is fitted on the front axle, you cannot use snow chains at the same time. On all-wheel drive cars the drive on the rear axle can be disconnected. The spare wheel must not be repaired. The correct tyre pressure for the spare wheel is stated in the tyre pressure table, see page 296.

! IMPORTANT

Never drive faster than 80 km/h with a spare wheel on the car.

! IMPORTANT

The car must never be driven fitted with more than one "Temporary Spare" wheel.

Summer and winter wheels

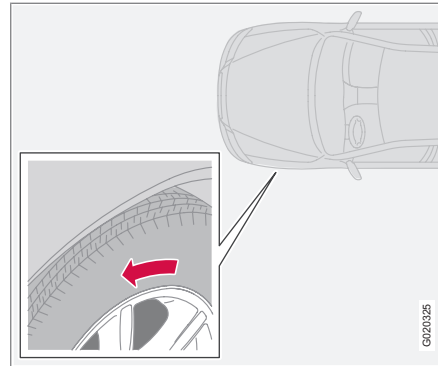

The arrow shows the tyre's direction of rotation.

When summer and winter wheels are changed, see page 199, the wheels should be marked with which side of the car they were mounted on, for example **L** for left and **R** for right. Tyres with a tread pattern which are designed to only turn in one direction have the direction of rotation marked with an arrow.

The tyre must always rotate in the same direction throughout its lifespan. Tyres should only be switched between front and rear positions, never between left and right-hand sides, or vice versa.

If the tyre is mounted incorrectly, the car's braking characteristics and capacity to force

rain, snow and slush out of the way are adversely affected.

Tyres with the greatest tread depth should always be fitted to the rear of the car (to decrease the risk of skidding).

Volvo recommends that you contact an authorised Volvo workshop for checking if you are uncertain about tread depth.



Tyre pressure

Recommended tyre pressure

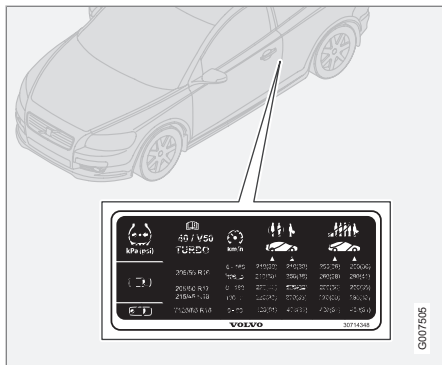

The tyre pressure label on the driver's side door pillar shows which pressures the tyres should have at different load and speed conditions.

- Tyre pressure for the car's recommended tyre size
- ECO pressure¹
- Spare tyre pressure (Temporary Spare).

Checking the tyre pressure

Check the tyre pressure regularly.

NOTE

Tyre pressure decreases over time, this is a natural phenomenon. Tyre pressure also varies depending on ambient temperature.

Even after several kilometres of driving, the tyres warm up and the pressure increases. So air must not be released if the pressure is checked when the tyres are warm. While the pressure must be increased if it is too low.

Inadequately inflated tyres increase fuel consumption, shorten tyre lifespan and impair the car's roadholding. Driving on tyres with tyre pressure that is too low can also result in the tyres overheating and disintegrating.

For information on the correct tyre pressure, refer to the tyre pressure table. The specified tyre pressures refer to "cold tyres". ("Cold tyres" means the tyres are the same temperature as the ambient temperature.)

Fuel economy, ECO pressure

At speeds under 160 km/h the general tyre pressure for maximum load is recommended in order to obtain optimum fuel economy.

Tyre pressure affects travelling comfort, road noise and steering characteristics.

DRIVE*

An important detail in connection with environmentally-conscious driving is to use the right type of tyres and to drive with the correct air pressure inside them.

Dimensions

When fitting new tyres, the same type and brand as the car was equipped with from the factory are recommended - they are designed for low fuel consumption.

The 195/65 R15 and 205/55 R16 dimensions generally provide a slightly lower consumption than wider variants.

Pressure

Inadequately inflated tyres increase fuel consumption. For this reason, check the pressure in the tyres regularly.

By using so-called ECO pressure² fuel consumption is minimised. A certain impact on ride comfort, road noise and steering characteristics may be experienced, but this does not affect safety.

See the decal with the recommended tyre pressure adjacent to the driver's door pillar.

¹ ECO pressure results in improved fuel economy.

² The pressure that is recommended for maximum load.



Warning triangle* and spare wheel *

Warning triangle

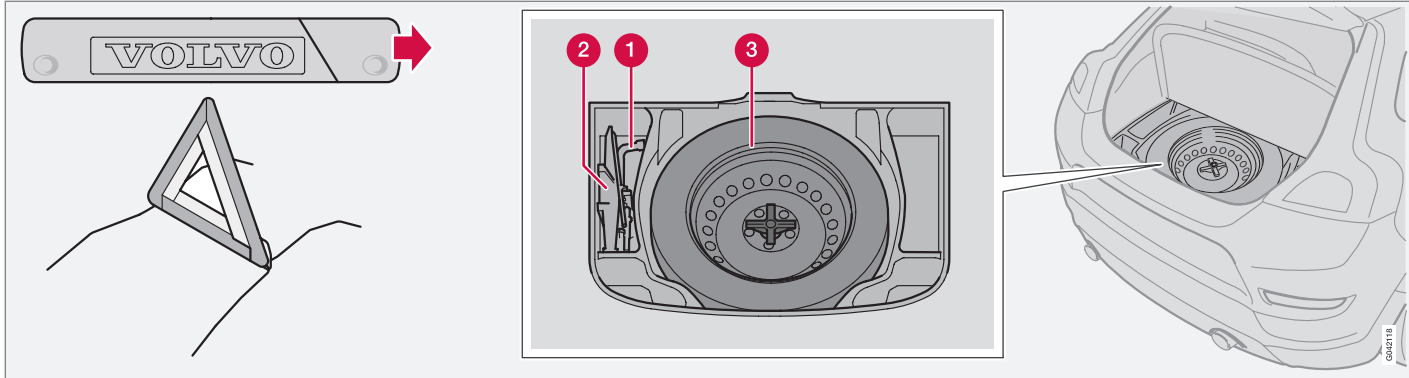

Follow the regulations for the use of a warning triangle*. Place the warning triangle in a suitable place with regard to the traffic.

1. Undo the case containing the warning triangle, it is secured with Velcro straps. Take the warning triangle from the case.
2. Lower the warning triangle's support legs.

Ensure the warning triangle and its case are firmly secured in the cargo area after use.

Spare wheel* and jack *

The car's original jack*

The original jack* must only be used for changing wheels. The jack's thread should always be well greased. The spare wheel* plus jack* and wheel wrench* are stored under the floor in the cargo area.

i NOTE

Volvo recommends only using the jack* that belongs to the car model in question, which is indicated on the jack's label.

The label also indicates the jack's maximum lift capacity at a specified minimum lifting height.

Taking out the spare wheel

A bolt runs through to secure the spare wheel.

1. Fold up the cargo area floor.
2. Unscrew the retaining bolt and lift out the wheel.



Warning triangle* and spare wheel *

Putting the spare wheel* and jack* into the cargo area

- 1 Wheel wrench*.
- 2 Jack* and handle, secured with a tensioning strap.
- 3 The spare wheel is bolted down with the rim side down using the through-bolt.

Tools - returning into place

Tools and jack* must be returned into place in the correct manner after use.

- For cars equipped with spare wheel, the jack must be cranked so that it fits into the spare wheel.
- For cars equipped with emergency puncture repair kit, the jack must be fully cranked together and returned into the foam block.

IMPORTANT

The tools and jack* must be stored in the intended location in the car's cargo area when not in use.

First aid*

A case with first aid equipment is located in the cargo area.



Changing wheels

Removing wheels

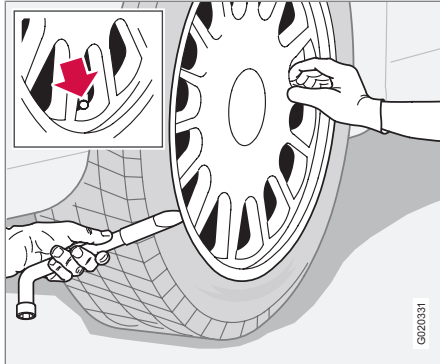

Set up the warning triangle if a wheel must be changed at a busy location. Make sure that the car and jack are on a firm horizontal surface.

WARNING

Check that the jack is not damaged, that the threads are thoroughly lubricated and that it is free from dirt.

NOTE

Volvo recommends only using the jack* that belongs to the car model in question, which is indicated on the jack's label.

The label also indicates the jack's maximum lift capacity at a specified minimum lifting height.

1. Take out the spare wheel*, the jack* and the wheel wrench* that are located under the carpet in the cargo area. If another jack is selected, see page 219.
2. Apply the parking brake and engage reverse gear, or position **P** if the car has an automatic gearbox.
3. Place chocks in front of and behind the wheels which will remain on the ground. Use heavy wooden blocks or large stones.
4. Cars with steel rims have removable wheel covers. Prize off the wheel cover with the end of the wheel wrench, or pull it off by hand.
5. Loosen the wheel nuts $\frac{1}{2}$ -1 turn anticlockwise with the wheel wrench.

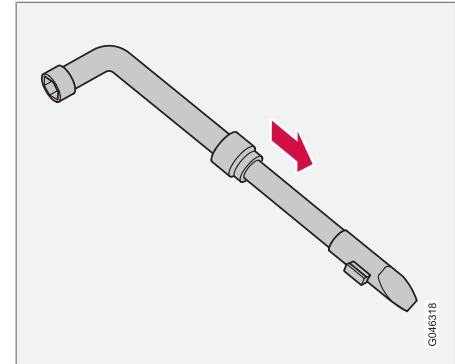

Telescopic wheel wrench.

6. There are two jacking points on each side of the car.



Changing wheels

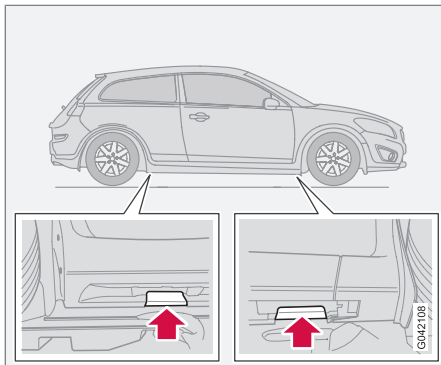

Jacking points

There is a recess in the plastic cover at each point. Crank the foot of the jack down so it is pressed squarely on the ground. Check that the jack is seated correctly in the intended jacking point, as illustrated, and that the base is located directly under it.

WARNING

Never position anything between the ground and the jack, nor between the jack and the car's jacking point.

IMPORTANT

The ground must be firm, smooth and level.

7. Lift the car so that the wheel is free. Remove the wheel nuts and lift off the wheel.

Fitting the wheel

1. Clean the contact surfaces between wheel and hub.
2. Put on the wheel. Tighten the wheel nuts.
3. Lower the car so that the wheel cannot rotate.
4. Tighten the wheel nuts crosswise. It is important that the wheel nuts are tightened properly. See page 194 for tightening torques. Check the torque with a torque wrench.
5. Put on the wheel cover (steel rim).

WARNING

Never crawl under the car when it is raised on the jack.

Passengers must leave the car when it is raised on the jack.

Ensure that passengers wait with the car - or preferably a crash barrier - between them and the road.

NOTE

The car's regular jack is designed only for use occasionally and for a short time, such as when changing a wheel with a punctured tyre, switching between summer tyres and winter tyres, etc. Only the jack belonging to the specific model is to be used to jack up the car. If the car is to be jacked up more often, or for a longer time than is required just to change a wheel, use of a garage jack is recommended. In this instance, follow the instructions for use that come with the equipment.



Emergency puncture repair*

Emergency puncture repair, general information

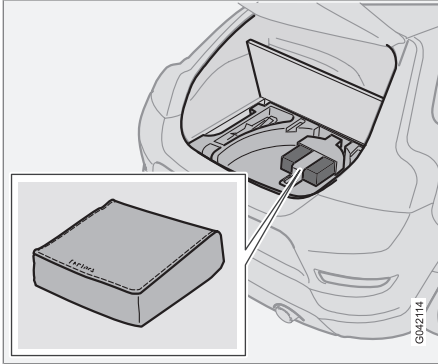

The emergency puncture repair kit is used to seal a puncture as well as to check and adjust the tyre pressure. It consists of a compressor and a bottle with sealing fluid. The kit works as a temporary repair. The sealing fluid bottle must be replaced before its expiration date and after use.

The sealing fluid effectively seals tyres punctured in the tread.

i NOTE

The emergency puncture repair kit is only intended for sealing tyres with a puncture in the tread.

The emergency puncture repair kit has limited capacity to seal tyres which have punctures in the wall. Do not seal tyres with the emergency puncture repair kit if they have larger slits, cracks or similar damage.

There are two 12 V sockets for connecting the compressor in the tunnel console, see page 54. Choose the electrical socket that is nearest the punctured tyre.

i IMPORTANT

If the compressor for emergency puncture repair is connected to one of the two sockets in the tunnel console, see page 54, no other current consumer must be connected to the other one.

i NOTE

The compressor for temporary emergency puncture repair has been tested and approved by Volvo.

⚠ WARNING

You should not drive faster than 80 km/h after the emergency tyre repair kit has been used. Volvo recommends that you visit an authorised Volvo workshop for inspection of the sealed tyre (maximum driving distance is 200 km). The staff there can determine whether or not the tyre can be repaired or if it needs to be replaced.

Taking out the emergency puncture repair kit

The emergency puncture repair kit with compressor and tools are stored under the floor in the cargo area.

1. Fold up the cargo area floor.
2. Unscrew the bolt and remove the holder.
3. Lift up the emergency puncture repair kit.



Emergency puncture repair*

Fitting the emergency puncture repair kit

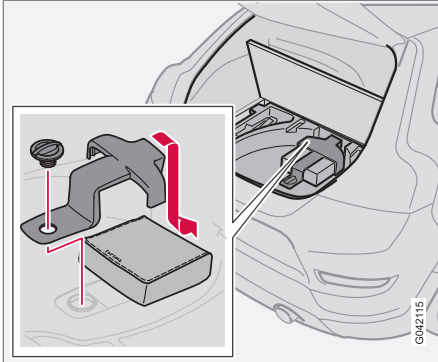

1. Insert the emergency puncture repair kit.
2. Align the holder in the inner and lower grooves of the spare wheel well
3. Screw in the bolt.

i NOTE

Incorrect installation of the holder may cause the emergency puncture repair kit to rattle.

Overview

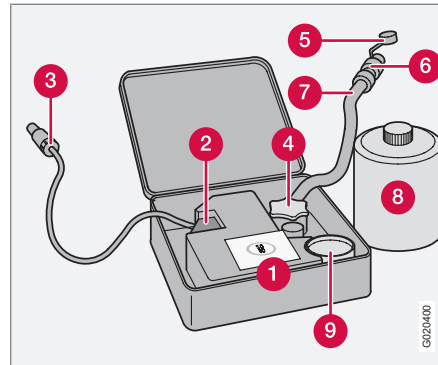

- 1 Decal, maximum permitted speed
- 2 Switch
- 3 Cable
- 4 Bottle holder (orange cap)
- 5 Protective cap
- 6 Pressure reducing valve
- 7 Air hose
- 8 Sealing fluid bottle
- 9 Pressure gauge

Sealing punctured tyres

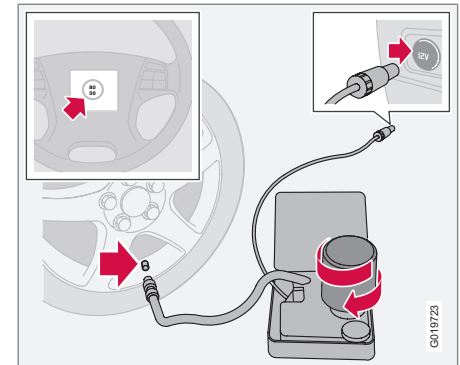

For information on the function of the parts, see preceding illustration.

1. Open the lid of the emergency puncture repair kit.
2. Detach the decal for maximum permitted speed and affix it to the steering wheel.

! WARNING

The sealing fluid can irritate the skin. In the case of contact with skin, wash away the fluid with soap and water.



Emergency puncture repair*

- Check that the switch is in position **0** and locate the cable and the air hose.

NOTE

Do not break the bottle's seal before use. The seal is broken automatically when the bottle is screwed in.

- Unscrew the orange cap and unscrew the bottle's stopper.
- Screw the bottle into its holder.

WARNING

Do not unscrew the bottle, it is equipped with a reverse catch to prevent leakage.

- Unscrew the wheel's dust cap and screw in the air hose valve connection to the bottom of the thread on the tyre's air valve.

WARNING

Do not leave children in the car without supervision when the engine is running.

- Plug the cable into the 12 V socket and start the car.

NOTE

If the compressor is connected to one of the two 12 V sockets, in the tunnel console, no other current consumer must be connected to the other one.

NOTE

When the compressor starts, the pressure can increase up to 6 bar but the pressure drops after approximately 30 seconds.

- Flick the switch to position **I**.

WARNING

Never stand next to the tyre when the compressor is running. If cracks or unevenness arise then the compressor must be switched off immediately. The journey should not be continued. Contacting an authorised tyre centre is recommended.

- Inflate the tyre for 7 minutes.

IMPORTANT

Risk of overheating. The compressor must not run for more than 10 minutes.

- Switch off the compressor to check the pressure on the pressure gauge. Minimum pressure is 1.8 bar and maximum is 3.5 bar.

WARNING

If the pressure is below 1.8 bar then the hole in the tyre is too big. The journey should not be continued. Contacting an authorised tyre centre is recommended.

- Switch off the compressor and unplug the cable from the 12 V socket.
- Detach the hose from the tyre valve and fit the valve cap.
- As soon as possible, drive approximately 3 km at a maximum speed of 80 km/h so that the sealing fluid can seal the tyre.

Rechecking the repair and pressure

- Reconnect the equipment.
- Read the tyre pressure on the pressure gauge.
- If it is below 1.3 bar then the tyre is insufficiently sealed. The journey should not be continued. Contact a tyre centre.
- If the tyre pressure is higher than 1.3 bar, the tyre must be inflated to the pressure



Emergency puncture repair*

specified on the tyre pressure decal. Release air using the pressure reducing valve if the tyre pressure is too high.

WARNING

Do not unscrew the bottle, it is equipped with a reverse catch to prevent leakage.

- Switch off the compressor. Detach the air hose and cable. Refit the dust cap.

NOTE

The sealing fluid bottle and the hose must be replaced after use. Volvo recommends that this replacement is performed by an authorised Volvo workshop.

WARNING

Check the tyre pressure regularly.

- Return the emergency puncture repair kit to the cargo area.
- Volvo recommends that you drive to the nearest authorised Volvo workshop for the replacement/repair of the damaged tyre. Advise the workshop that the tyre contains sealing fluid.

WARNING

You should not drive faster than 80 km/h after the emergency tyre repair kit has been used. Volvo recommends that you visit an authorised Volvo workshop for inspection of the sealed tyre (maximum driving distance is 200 km). The staff there can determine whether or not the tyre can be repaired or if it needs to be replaced.

Inflating the tyres

The car's original tyres can be inflated by the compressor.

- The compressor must be switched off. Make sure that the switch is in position **0** and locate the cable and air hose.
- Unscrew the wheel's dust cap and screw in the air hose valve connection to the bottom of the thread on the tyre's air valve.

WARNING

Inhaling car exhaust fumes could result in danger to life. Never leave the engine running in sealed areas or areas that lack sufficient ventilation.

WARNING

Do not leave children in the car without supervision when the engine is running.

- Connect the cable to one of the car's 12 V sockets and start the car.
- Start the compressor by flicking the switch to position **I**.

IMPORTANT

Risk of overheating. The compressor must not run for more than 10 minutes.

- Inflate the tyre to the pressure specified on the tyre pressure decal. (Release air using the pressure reducing valve if the tyre pressure is too high.)
- Switch off the compressor. Detach the air hose and cable.
- Refit the dust cap.

**Emergency puncture repair*****Changing the sealing fluid canister**

Replace the bottle before the expiration date has passed. Treat the old bottle as environmentally hazardous waste.

**WARNING**

The bottle contains 1,2-Ethanol and natural rubber-latex.

Harmful if ingested. Could result in allergic reaction in the event of skin contact.

Avoid contact with the skin and eyes.

Store out of the reach of children.

**NOTE**

Leave the container at a collection point for storing dangerous waste.

Cleaning.....	208
Touching up paintwork.....	212
Rustproofing.....	214



08

CAR CARE

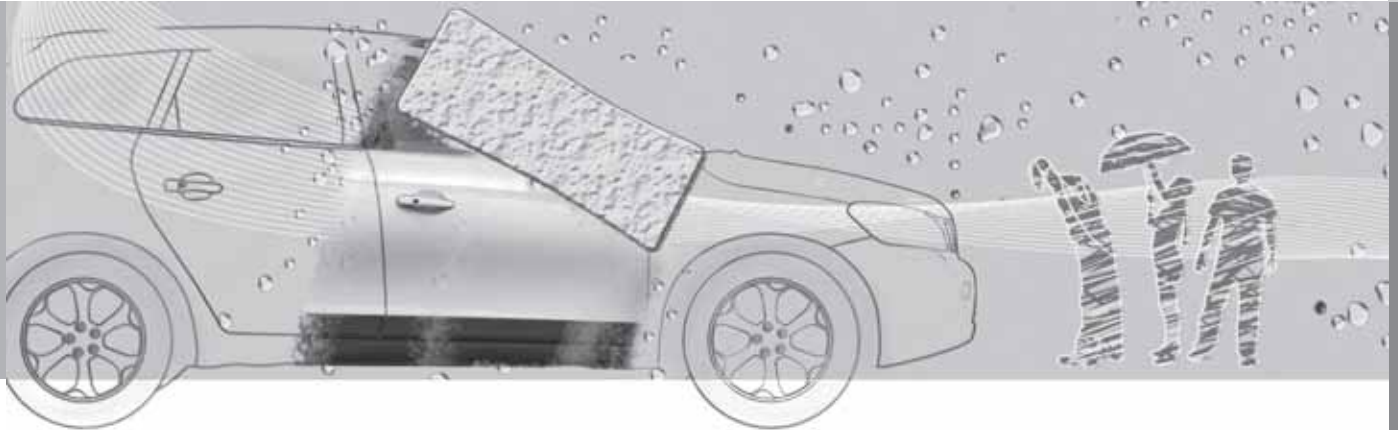



Cleaning

Washing the car

Wash the car as soon as it becomes dirty. Wash the car in a car wash with oil separator. Use car shampoo.

- Remove bird droppings from the paintwork as soon as possible. Bird droppings contain chemicals that affect and discolour paintwork very quickly. An authorised Volvo workshop is recommended for the removal of any discoloration.
- Hose down the underbody.
- Rinse the whole car until the loose dirt has been removed in order to reduce the risk of scratches from washing. Do not spray directly onto the locks.
- If necessary, use cold degreasing agent on very dirty surfaces. Note that the surfaces must not then be warmed up by the sun!
- Wash using a sponge, car shampoo and plenty of lukewarm water.
- Clean the wiper blades with a lukewarm soap solution or car shampoo.
- Use cold degreasing agent on very dirty surfaces.
- Dry the car using a clean, soft chamois or a water scraper. If you avoid allowing water droplets to dry in strong sunlight then the risk of water stains that may need to be polished away is reduced.

WARNING

Always have the engine cleaned by a workshop. There is a risk of fire if the engine is hot.

IMPORTANT

Dirty headlamps have impaired functionality. Clean them regularly, when refuelling for example.

Do not use any corrosive cleaning agents but use water and a non-scratching sponge instead.

NOTE

Outside lighting such as headlamps, fog lamps and rear lamps may temporarily have condensation on the inside of the lens. This is a natural phenomenon, all outside lighting is designed to withstand this. Condensation is normally vented out of the lamp when it has been switched on for a time.

Cleaning the wiper blades

Asphalt, dust and salt residue on wiper blades, as well as insects, ice etc. on the windscreen, impair the service life of wiper blades.

NOTE

Wash the wiper blades and windscreen regularly with lukewarm soap solution or car shampoo.

Do not use any strong solvents.

Removing bird droppings

Wash away bird droppings from the paintwork as soon as possible. Bird droppings contain chemicals that affect and discolour paintwork very quickly. This discoloration can only be removed by a specialist.

Chromed wheels

IMPORTANT

Rim cleaning agents can cause stains on chrome-plated wheels. Wash using a sponge, car shampoo and plenty of lukewarm water.

High-pressure washing

When using high-pressure washing, use sweeping movements and make sure that the nozzle does not come closer than 30 cm to the surface of the car (the distance applies to all exterior parts).



Cleaning

IMPORTANT

Rinse the entire car to remove loose dirt. When using a pressure washer: Make sure that the nozzle of the pressure washer is not closer than 30 cm to the bodywork. Do not spray directly onto the locks.

Testing the brakes

WARNING

Always test the brakes after washing the car, including the parking brake, to ensure that moisture and corrosion do not attack the brake linings and reduce braking performance.

Lightly depress the brake pedal now and then when driving long distances in rain or slush. This heats and dries the brake pads. Do the same thing after starting in very damp or cold weather.

Exterior plastic, rubber and trim components

A special cleaning agent available from Volvo dealers is recommended for the cleaning and care of coloured plastic parts, rubber and trim components (such as glossy trim mouldings). When using such a cleaning agent the instructions must be followed carefully.

IMPORTANT

Avoid waxing and polishing on plastic and rubber.

When using degreasant on plastic and rubber, only rub with light pressure if it is necessary. Use a soft washing sponge.

Polishing glossy trim mouldings could wear away or damage the glossy surface.

Polishing agent that contains abrasive must not be used.

Polishing and waxing

Polish and wax the car if the paintwork is dull or to give the paintwork extra protection.

The car does not need to be polished until it is at least one year old. However, the car can be waxed before this time. Do not polish or wax the car in direct sunlight.

Wash and dry the car thoroughly before you begin polishing or waxing. Clean off asphalt and tar stains using tar remover or white spirit. More stubborn stains can be removed using fine rubbing paste designed for car paintwork.

Polish first with a polish and then wax with liquid or solid wax. Follow the instructions on the packaging carefully. Many preparations contain both polish and wax.

IMPORTANT

Only paint treatment recommended by Volvo should be used. Other treatment such as preserving, sealing, protection, lustre sealing or similar could damage the paintwork. Paintwork damage caused by such treatments is not covered by Volvo warranty.

Cleaning the interior

Only use cleaning agents and car care products recommended by Volvo. Clean regularly and follow the instructions included with the car care product.

Vacuuming is important prior to using cleaning agents.

Carpets and cargo area

Remove inlaid carpets for separate cleaning of the floor carpet and the inlaid carpets. Use a vacuum cleaner to remove dust and dirt.

Each inlay mat is secured with pins.

- Take hold of the inlay mat at each pin and lift the mat straight up.

Fit the inlay mat in place by pressing it in at each pin.



Cleaning

WARNING

Before setting off check that the inlaid mat in the driver area is firmly affixed and secured in the pins in order to avoid getting caught adjacent to and under the pedals.

A special textile cleaner is recommended for stains on the floor mat after vacuuming. Floor mats should be cleaned with agents recommended by your Volvo dealer!

Treatment of stains on textile upholstery and headliner

A special fabric cleaning agent, available from authorised Volvo dealers, is recommended to avoid impairing the fire retardant qualities of the upholstery.

IMPORTANT

Sharp objects and Velcro may damage the fabric upholstery.

Treating stains on leather upholstery

Volvo's leather upholstery is chromium-free and is treated to preserve its original appearance.

Leather upholstery ages and acquires a beautiful patina over time. The leather is refined and processed so that it retains its natural characteristics. It is given a protective coating, but

regular cleaning is required in order to maintain both characteristics and appearance. Volvo offers a comprehensive product for the cleaning and treatment of leather upholstery which, when used in accordance with the instructions, preserves the leather's protective coating.

After a period of use the natural appearance of the leather will nevertheless emerge, depending more or less on the surface texture of the leather. This is a natural maturing of the leather and shows that it is a natural product.

To achieve best results Volvo recommends cleaning and the application of protective cream once to four times per year (or more if necessary). The Volvo Leather Care kit is available from your Volvo dealer.

IMPORTANT

- Certain items of coloured clothing (for example, jeans and suede garments) may stain the upholstery.
- Never use strong solvents. Such products may damage fabric, vinyl and leather upholstery.

Washing instructions for leather upholstery

1. Pour the leather cleaner on the dampened sponge and squeeze out a strong foam.

2. Work the dirt away with gentle circular movements.
3. Dab accurately with the sponge on the stains. Allow the sponge to absorb the stain. Do not rub.
4. Wipe off with soft paper or a cloth and allow the leather to dry completely.

Protective treatment of leather upholstery

Vacuuming is important prior to using leather care agents.

1. Pour a small amount of the protective cream on the felted cloth and massage in a thin layer of cream with gentle circular movements on the leather.
2. Allow the leather to dry for 20 minutes before use.

The leather has now been given improved protection against stains and improved UV protection.

IMPORTANT

Sharp objects may damage the leather, (e.g. rings).



Washing instructions for the leather steering wheel

- Remove dirt and dust with a soft pre-moistened sponge and neutral soap.
- Leather needs to breathe. Never cover the leather steering wheel with protective plastic.
- Use natural oils. Volvo's leather care agents are recommended for best results.

If the steering wheel has stains:

Group 1 (ink, wine, coffee, milk, sweat and blood)

- Use a soft cloth or sponge. Mix a 5% ammonia solution. (For blood stains, use a solution of 2 dl water and 25g salt.)

Group 2 (fats, oils, sauces and chocolate)

1. Same procedure as for group 1.
2. Polish with an absorbent paper or cloth.

Group 3 (dry dirt, dust)

1. Use a soft brush to remove the dirt.
2. Same procedure as for group 1.

Treating stains on interior plastic, metal and wood parts

A special cleaning agent, available from Volvo dealers, is recommended for cleaning interior parts and surfaces. Do not scrape or rub stains. Never use strong stain removers.

Cleaning seatbelts

Use water and a synthetic detergent. A special textile cleaning agent is available from your Volvo dealer. Make sure the seatbelt is dry before allowing it to retract.



Touching up paintwork

Paintwork

Paint is an important part of the car's rust-proofing and should therefore be checked regularly. To avoid the onset of rust, damaged paintwork should be rectified immediately. The most common types of paintwork damage are stone chips, scratches, and marks on the edges of wings, doors and bumpers.

Colour code (Paint code)

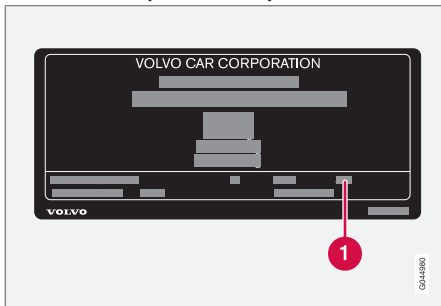

Data plate.

1 Code for car's colour

It is important that the correct colour is used. For product decal location, see page 284.

¹ If required.

² Follow the instructions that are included with the package for the touch-up pen/stick.

Stone chips and scratches

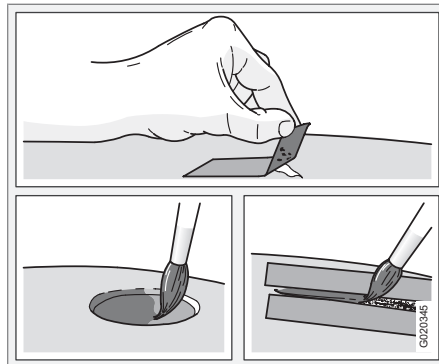

Before work is started, the car must be clean and dry as well as at a temperature above 15 °C.

Materials

- primer¹ - for e.g. plastic-clad bumpers there are special adhesive primers available in spray cans
- base coat and clear coat - are available in spray cans or as touch-up pens/sticks²
- masking tape
- fine sand paper¹.

Repairing minor paint damage such as stone chips and scratches

1. Apply a piece of masking tape over the damaged surface. Then remove the tape to remove any loose paint.

If the damage has reached down to a metal surface (sheet steel), it is preferable to use a primer. In the event of damage to a plastic surface, an adhesive primer should be used for better results - spray into the spray can's cap and brush thinly.

2. A light sanding with very fine abrasive material can be performed locally before painting if necessary (e.g. if there are rough edges). Clean the surface thoroughly and allow to dry.
3. Stir the primer well and apply using a fine brush, matchstick or similar. Finish with base coat and clear coat once the primer has dried.
4. For scratches, proceed as above, but mask around the damaged area to protect the undamaged paintwork.



Touching up paintwork



NOTE

If the stone chip has not penetrated down to the metal and an undamaged layer of paint remains in place, fill in with base coat and clear coat as soon as the surface has been cleaned.



Rustproofing

Inspection and maintenance

Your car has already received a thorough and complete rustproofing at the factory. Parts of the body are made of galvanised sheet metal. The underbody is protected by a wear-resistant anti-corrosion compound. A thin, penetrating rustproofing fluid was sprayed into the members, cavities and closed sections.

Maintain the car's rustproofing.

- Keep the car clean. Hose down the underbody. If using a pressure washer, keep the nozzle at least 30 cm from the painted surfaces.
- Regularly check and touch-up the rustproofing treatment as necessary.

The car's rustproofing does not normally require treatment for approximately 12 years. After this period, it should be treated at three-year intervals. If the car needs further treatment, Volvo recommends that you engage an authorised Volvo workshop for assistance.



Volvo service.....	218
Self-maintenance.....	219
Bonnet and engine compartment.....	220
Oils and fluids.....	222
Wiper blades.....	228
Battery.....	230
Replacing bulbs.....	234
Fuses.....	240



09

MAINTENANCE AND SERVICE

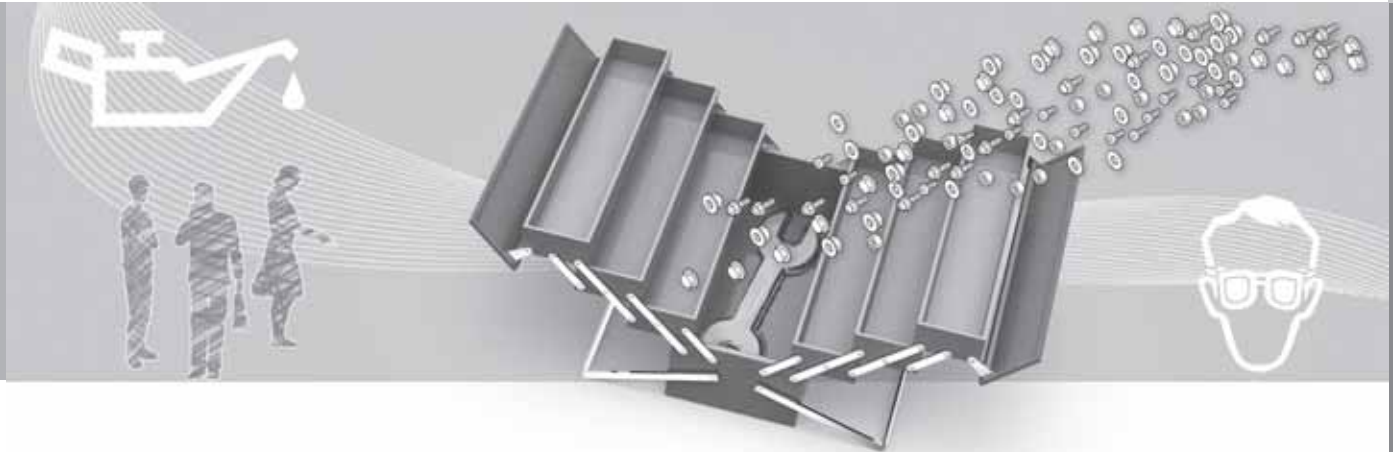



Volvo service

Volvo service programme

Before the car left the factory, it was thoroughly test driven. It was checked again in accordance with Volvo Car Corporation regulations before it was handed over to you.

To keep your Volvo as safe and reliable as possible, follow the Volvo service programme specified in the Service and Warranty Booklet. Volvo also recommends that you engage an authorised Volvo workshop to perform the service and maintenance work. Volvo workshops have the personnel, special tools and service literature to guarantee the highest quality of service.



IMPORTANT

For the Volvo warranty to apply, check and follow the instructions in the Service and Warranty Booklet.

Special service measures

Certain service measures which affect the car's electrical system can only be performed using electronic equipment specially developed for your car. For this reason, Volvo recommends that you always contact an authorised Volvo workshop before beginning or performing service work that affects the electrical system.



Self-maintenance

Before starting work on the car

Battery

Check that the battery cables are correctly connected and tightened.

Never disconnect the battery when the engine is running (e.g. if replacing the battery).

Never use a quick charger to charge the battery. The battery cables must be disconnected when charging the battery.

The battery contains acid that is both corrosive and toxic. It is therefore important to handle the battery in an environmentally correct manner. Let your Volvo dealer assist you.

WARNING

The ignition system has very high voltage and output. The voltage in the ignition system is highly dangerous. The ignition must therefore always be switched off for work in the engine compartment.

Do not touch the spark plugs or ignition coils when the ignition is on or the engine is hot.

Raising the car

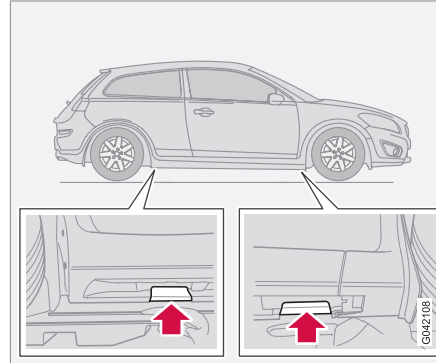

NOTE

Volvo recommends only using the jack that belongs to the car model in question. If a jack is selected other than the one recommended by Volvo, follow the instructions for use supplied with the equipment.

If the car is raised with a workshop jack; position the jack against the front edge on the subframe.

Do not damage the splashguard under the engine. Ensure that the jack is positioned so that the car cannot slide off the jack. Always use axle stands or similar.

If you raise the car using a two-pillar workshop lift, ensure that the front and rear lift arms are fixed under the lifting points. See preceding illustration.

Check regularly

Check the following at regular intervals, for example, when refuelling:

- Coolant – The level must be between the **MIN** and **MAX** marks on the expansion tank.
- Engine oil – The level must be between the **MIN** and **MAX** marks.
- Power steering fluid – The level must be between the **MIN** and **MAX** marks.
- Washer fluid – The reservoir should be well filled. Fill washer fluid with antifreeze at temperatures around freezing point.
- Brake and clutch fluid – The level must be between the **MIN** and **MAX** marks.

WARNING

Remember that the radiator fan (located at the front of the engine compartment, behind the radiator) may start automatically some after the engine has been switched off.

Always have the engine cleaned by a workshop. There is a risk of fire if the engine is hot.



Bonnet and engine compartment

Opening the bonnet

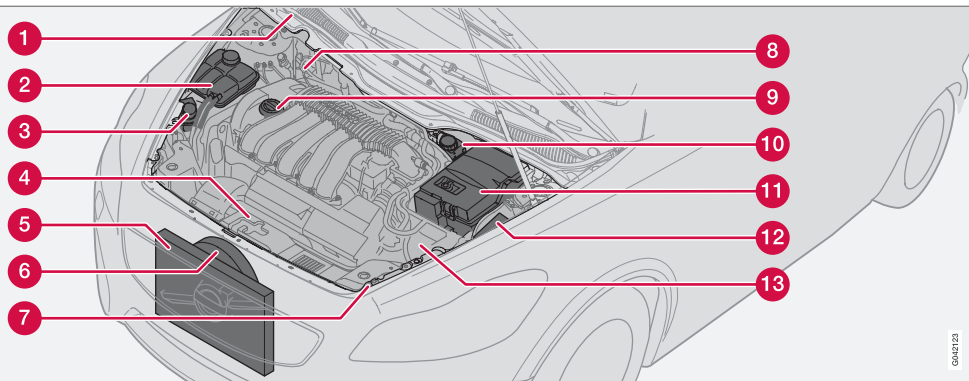
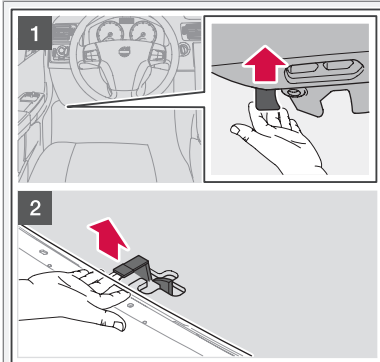

The illustration shows a left-hand drive car.

1. Pull the handle on the far left under the instrument panel. (In right-hand drive cars the handle is on the far right.) You will hear when the catch releases.
2. Insert your hand under the centre of the front edge of the bonnet and press the safety catch to the right.
3. Open the bonnet.

WARNING
Check that the bonnet locks properly when closed.

Engine compartment

- | | |
|---|---|
| <ul style="list-style-type: none"> 1 Washer fluid reservoir (4-cyl.) 2 Coolant expansion tank 3 Reservoir for the power steering fluid (concealed behind the headlamp) | <ul style="list-style-type: none"> 4 Dipstick¹ for engine oil² 5 Radiator 6 Radiator fan 7 Washer fluid reservoir (5-cyl.) 8 Brake and clutch fluid reservoir (right-hand drive) 9 Filling the engine oil² |
|---|---|

¹ Engines with electronic oil level sensor have no dipstick (5-cyl. diesel).

² The location varies depending on engine alternative.

0641123

**Bonnet and engine compartment**

- 10 Brake and clutch fluid reservoir (left-hand drive)
- 11 Battery
- 12 Relay and fuse box
- 13 Air filter²

Climate control system**Fault tracing and repair**

The air conditioning system contains a fluorescent tracing agent. Use ultraviolet light during leakage detection.

Volvo recommends that you contact an authorised Volvo workshop.

**WARNING**

The air conditioning system contains pressurised refrigerant R134a. This system must only be serviced and repaired by an authorised workshop.

² The location varies depending on engine alternative.



Oils and fluids

Checking the engine oil

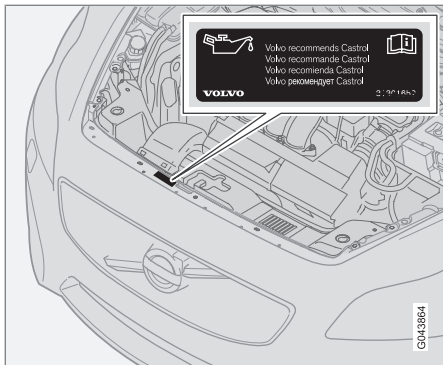

Volvo recommends Castrol oil products.

! IMPORTANT

Always use oil of the prescribed grade. Check the oil level frequently and change the oil regularly. The engine will be damaged if lower grade oil is used or if the car is driven with the oil level too low.

When driving under adverse conditions, see page 290.

! IMPORTANT

In order to fulfil the requirements for the engine's service intervals all engines are filled with a specially adapted synthetic engine oil at the factory. The choice of oil has been made very carefully with regard to service life, starting characteristics, fuel consumption and environmental impact.

An approved engine oil must be used in order that the recommended service intervals can be applied. Only use a prescribed grade of oil for both filling and oil change, otherwise you will risk affecting service life, starting characteristics, fuel consumption and environmental impact.

Volvo Car Corporation disclaims all warranty liability if engine oil of the prescribed grade and viscosity is not used.

Volvo recommends that oil changes are carried out at an authorised Volvo workshop.

Volvo uses different systems for warning of low/high oil level or low/high oil pressure. Certain variants have an oil pressure sensor, and then the lamp for oil pressure is used. Other variants have an oil level sensor, and then the driver is informed via the warning symbol in the centre of the instrument unit as well as by display texts. Certain models have both variants. Contact a Volvo dealer for more information.

Change the engine oil and oil filter in accordance with the intervals specified in the Service and Warranty Booklet.

Using oil of a higher than specified grade is permitted. If the car is driven in adverse conditions, Volvo recommends using an oil of a higher grade, see page 290.

For capacities, see page 291 and onwards.

Engine with oil dipstick¹

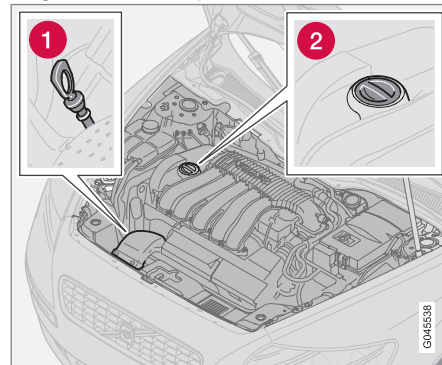

Petrol engine.

- 1 Dipstick, petrol engines.
- 2 Filler pipe, engine oil.

¹ Only applies to petrol and 4-cyl. diesel.



Oils and fluids

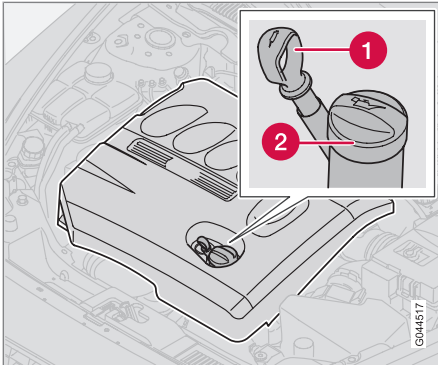

Diesel engine.

- 1 Dipstick, 4-cyl diesel engines.
- 2 Filler pipe, engine oil.

Checking the oil level in a new car is especially important before the first scheduled oil change.

Volvo recommends checking the oil level every 2 500 km. The most accurate measurements are made on a cold engine before starting. The measurement will be inaccurate if taken immediately after the engine is switched off. The dipstick will indicate that the level is too low because the oil has not had time to flow down into the oil sump.

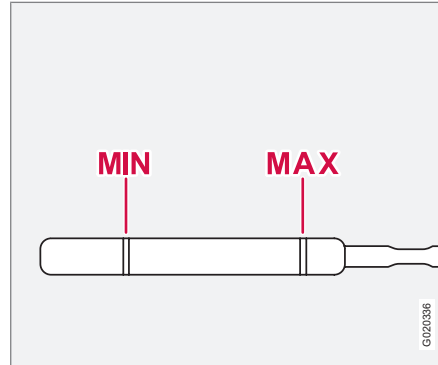

The oil level must be within the area marked on the dipstick.

Measurement and filling if required

1. Ensure that the car is level. After switching off the engine it is important to wait 5 minutes to allow the oil time to run back to the sump.
2. Pull up and wipe the dipstick.
3. Re-insert the dipstick.
4. Pull it out and check the level.
5. If the level is close to **MIN** then 0.5 litres should be added. If the level is significantly

below, then an additional amount is required.

6. If required, check the level again, do it after driving a short distance. Then repeat steps 1 - 4.

WARNING

Never fill above the **MAX** mark. The level should never be above **MAX** or below **MIN** as this could lead to engine damage.

WARNING

Do not spill oil onto the hot exhaust manifold due to the risk of fire.



Oils and fluids

For engines with electronic oil level sensor²

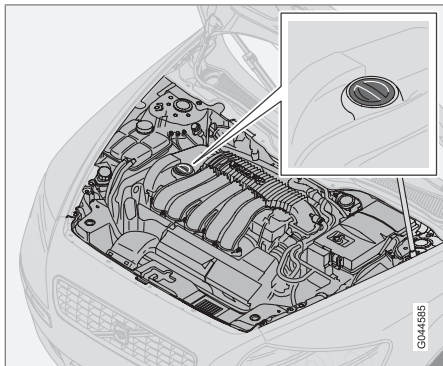

Filler pipe.³

You do not need to take action with respect to the engine oil level before a message is shown in the display, see the illustration below.

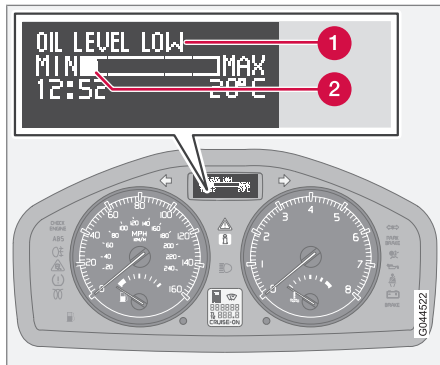

Message and graph in the display.

- 1 Message
- 2 Engine oil level

The oil level is checked using the electronic oil level gauge with the thumbwheel when the engine is switched off, see page 62.

WARNING

If the message **Oil service required** is shown, visit a workshop. The oil level may be too high.

IMPORTANT

In the event of the message **Oil level low**, Fill oil, only fill with 0.5 litres.

NOTE

The oil level is only detected by the system during driving. The system cannot directly detect changes when the oil is filled or drained. The car must be driven about 30 km before the oil level display is correct.

WARNING

Do not fill more oil if filling level (3) or (4) appears as shown in the illustration below. The level must never be above **MAX** or below **MIN**, as this could lead to engine damage.

WARNING

Do not spill oil onto the hot exhaust manifold due to the risk of fire.

² Only applies to 5-cyl. diesel.

³ Engines with electronic oil level sensor have no dipstick (5-cyl. diesel).



Oils and fluids

Measuring the oil level

If the oil level needs to be checked then it should be carried out in accordance with the sequence below.

1. Activate key position II, see page 150.
2. Rotate the thumbwheel on the left-hand stalk switch to position **Engine oil level**
Please wait....
 - > You will then see information displayed about the engine oil level.

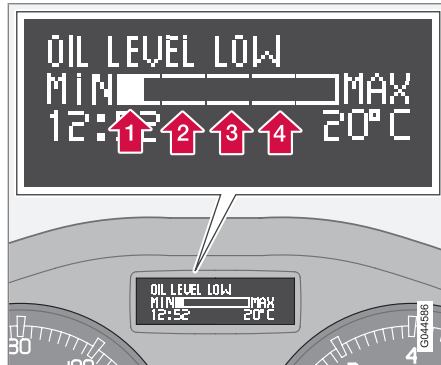

The figures 1-4 represent filling level. Do not fill more oil if filling level (3) or (4) is shown. Recommended filling level is 4.

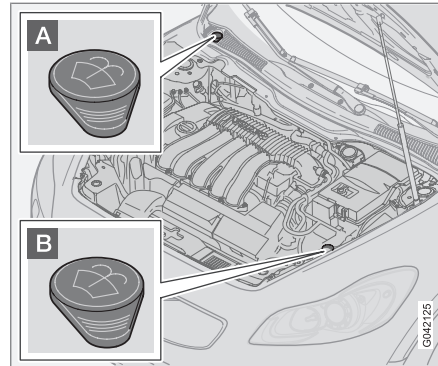
Washer fluid, topping up

The windscreen and headlamp washers share a common reservoir.

For capacities, see the table Fluids on page 293.

- A** Filling in cars with diesel engine.
- B** Filling in cars with petrol engine.

Add washer fluid with antifreeze in the winter so that the fluid does not freeze in the pump, reservoir and hoses.

NOTE

Mix concentrated washer fluid with water **before** filling.

TIP! Clean the wiper blades when topping up washer fluid.

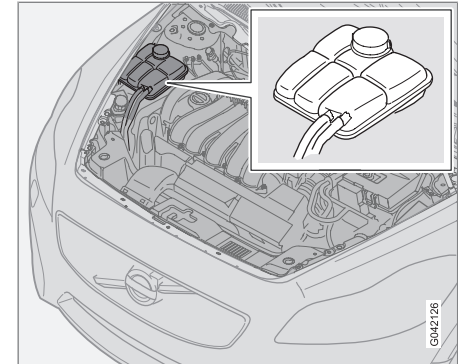
Checking and topping up the coolant

When topping up the coolant, follow the instructions on the packaging. It is important that the mixture of coolant concentrate and water is correct for the prevailing weather conditions. Never top up with water only. The risk of freezing increases with both too little and too much coolant concentrate.



Oils and fluids

! IMPORTANT

- A high content of chlorine, chlorides and other salts may cause corrosion in the cooling system.
- Always use coolant with anti-corrosion agent as recommended by Volvo.
- Ensure that the coolant mixture is 50% water and 50% coolant.
- Mix the coolant with approved quality tap water. In the event of any doubt about water quality, used ready-mixed coolant in accordance with Volvo recommendations.
- When changing coolant/replacing cooling system components, flush the cooling system clean with approved quality tap water or flush with ready-mixed coolant.
- The engine must only be run with a well-filled cooling system. Otherwise, temperatures that are too high may occur resulting in the risk of damage (cracks) in the cylinder head.

For capacities and for standards regarding water quality, see page 293.

Check the coolant regularly

The level must lie between the **MIN** and **MAX** marks on the expansion tank. If the system is not filled sufficiently, high local temperatures could occur, causing a risk of damage (cracks) to the cylinder head. Top up the coolant when the level falls to the **MIN** mark.

! WARNING

Coolant can be very hot. If the coolant requires topping up when the engine is at operating temperature, unscrew the expansion tank cap slowly to gently release the overpressure.

i NOTE

The engine must only be run with a well-filled cooling system. Otherwise, temperatures that are too high may occur resulting in the risk of damage (cracks) in the cylinder head.

Checking and topping up the brake and clutch fluid

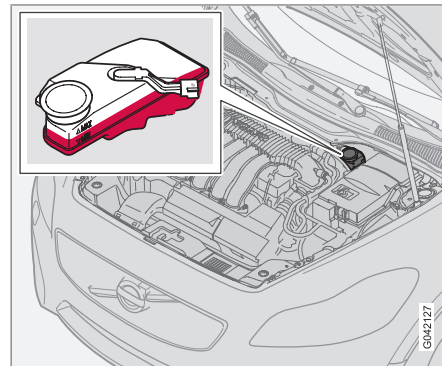

Brake and clutch fluid have a common reservoir⁴. The fluid level must be between the **MIN** and **MAX** marks. Check the level regularly. Change the brake fluid every other year or at every other regular service.

For capacities and recommended fluid grade, see the table Fluids on page 293.

The fluid should be changed annually on cars driven in conditions requiring hard, frequent braking, such as driving in mountains or tropical climates with high humidity.

⁴ Location dependent on whether car is left or right-hand drive.

**⚠ WARNING**

If the brake fluid is under the **MIN** level in the brake fluid reservoir, do not drive further before topping up the brake fluid.

The reason for the loss of brake fluid must be investigated.

Checking and topping up the power steering fluid**i NOTE**

Check the level frequently.

The fluid does not require changing. For capacities and recommended fluid grade, see page 293.

If a fault should arise in the power steering system or if the car is without power and must be towed, it can still be steered. However, the steering will be much heavier than normal and it will require more effort to turn the steering wheel.



Wiper blades

Wiper blades

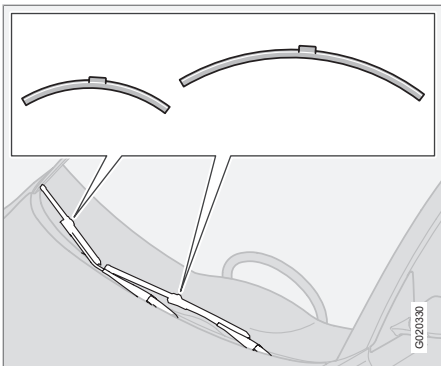

G020333

i NOTE

The wiper blades are different lengths. The blade on the driver's side is longer than on the other side.

Cleaning

For cleaning wiper blades and windscreen, see page 208.

! IMPORTANT

Check the wiper blades regularly. Neglected maintenance shortens the service life of the wiper blades.

Replacing the wiper blades, windscreen

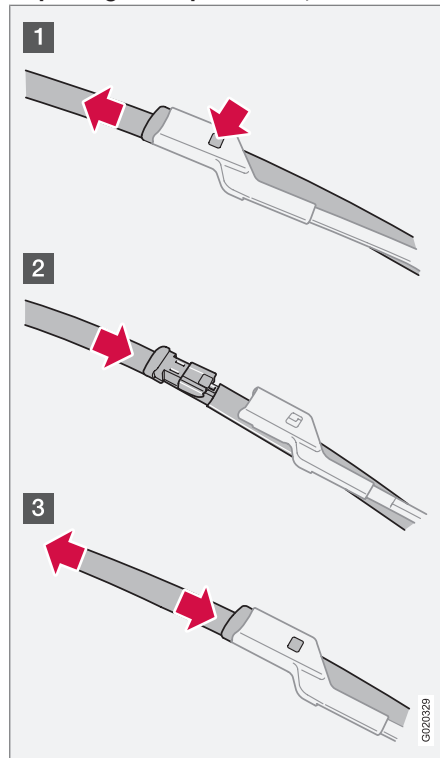

G020329

- 1 Lift up the wiper arm.
- 2 Press the button located on the wiper blade mounting and pull straight out (1), parallel with the wiper arm.
- 3 Slide in (2) the new wiper blade until a "click" is heard.
 - > Check (3) that the blade is firmly installed and fold down the wiper arm.

Changing the rear window wiper blade

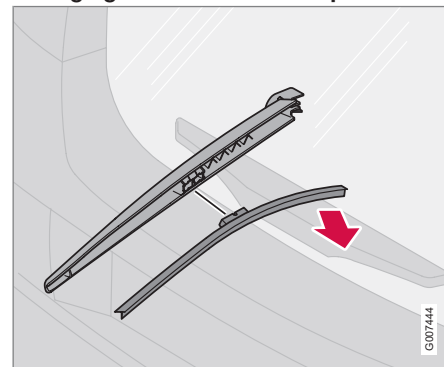

G007444

1. Fold out the wiper arm.
2. Detach the wiper blade by pulling it towards the rear window.
3. Press the new wiper blade into position.



Wiper blades

09

- > Check that it is firmly installed and fold back the wiper arm.



Battery

Operation

The service life and function of the battery is influenced by factors such as the number of starts, discharging, driving style, driving conditions and climatic conditions.

- Never disconnect the battery when the engine is running.
- Check that the cables to the battery are correctly connected and properly tightened.



WARNING

- The battery can generate oxyhydrogen gas, which is highly explosive. A spark can be formed if a jump lead is connected incorrectly, and this can be enough for the battery to explode.
- The battery contains sulphuric acid, which can cause serious burns.
- If sulphuric acid comes into contact with eyes, skin or clothing, flush with large quantities of water. If acid splashes into the eyes - seek medical attention immediately.



NOTE

The life of the battery is shortened if it becomes discharged repeatedly.

The life of the battery is affected by several factors, including driving conditions and climate. Battery starting capacity decreases gradually with time and therefore needs to be recharged if the car is not used for a longer time or when it is only driven short distances. Extreme cold further limits starting capacity.

To maintain the battery in good condition, at least 15 minutes of driving/week is recommended or that the battery is connected to a battery charger with automatic trickle charging.

A battery that is kept fully charged has a maximum service life.

Symbols on the battery

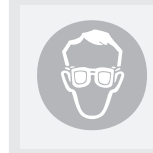

Use protective goggles.

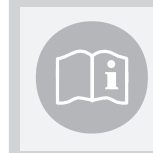

Further information in the owner's manual.



Store the battery out of the reach of children.



The battery contains corrosive acid.

**Battery**

Avoid sparks and naked flames.



Risk of explosion.



Must be taken for recycling.

GG44513

i NOTE

An expended battery must be recycled in an environmentally correct manner as it contains lead.

Changing the battery**Removal**

1. Remove the remote control key from the ignition switch.
2. Wait at least 5 minutes before touching any electrical terminals.
 - > The car's electrical system needs to store the necessary information to the control modules.
3. Remove the cover.
4. Detach the black negative cable.

**WARNING**

Connect and remove the positive and negative cables in the correct order.

5. Detach the red positive cable.
6. Undo the front wall of the battery box using a screwdriver.
7. Detach the ventilation hose from the battery.
8. Release the clamp securing the battery.
9. Remove the battery.

Fitting

1. Fit the battery into position.

2. Tighten the clamp that holds the battery.
3. Connect the ventilation hose.
 - > Check that it is correctly connected to both battery and outlet in the body.
4. Reinstall the front wall of the battery box.
5. Connect the red positive cable.
6. Connect the black negative cable.
7. Attach the cover to the battery.

For more information on the car's battery - see pages 178 and 298.

DRIVE Start/Stop*

Cars with the Start/Stop function are equipped with two 12 V batteries - one extra powerful battery for starting and one standby battery that helps during the Start/Stop function's starting sequence.

For more information on Start/Stop - see page 161.



Battery

Battery	Start	Standby
Cold start capacity ^A , CCA (A)	760	120
Dimensions ^B , LxWxH (mm)	278x175x190	150x90x106
Capacity (Ah)	70	8

A In accordance with the SAE standard.

B Largest possible size.

i NOTE

- The higher the current take-off in the car (extra cooling/heating, etc.) the more the batteries must be charged = increased fuel consumption.
- When the capacity of the battery has fallen below the lowest permissible level then the Start/Stop function is disengaged.

Temporarily reduced Start/Stop function due to high current take-off means:

¹ Auto-start can only take place if the gear lever is in neutral position.

² The battery is described in detail on page 230.

- The engine auto-starts¹ without the driver depressing the clutch pedal.

Location of the batteries

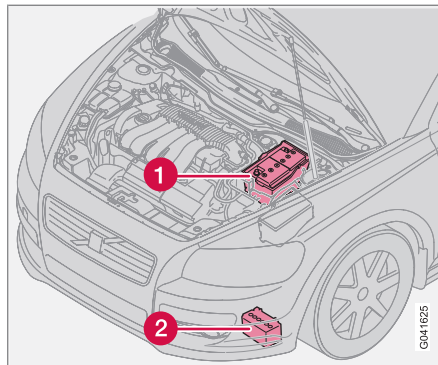

1. Battery² 2. Standby battery.

The standby battery normally requires no more service than the normal battery that is used for starting. A workshop should be contacted in the event of questions or problems - an authorised Volvo workshop is recommended.

i IMPORTANT

If the following instruction is not observed then the Start/Stop function may temporarily cease to work after the connection of an external battery or battery charger:

- The negative battery terminal on the car's main battery must **never** be used for connecting an external battery or battery charger - only the **car chassis** may be used as the grounding point.

See the section "Start assistance" - for a description of how the cable clamps must be attached.

**NOTE**

If the battery has become so discharged that everything is "black" and in principle the car does not have all the normal electrical functions and the engine is subsequently started using an external battery or battery charger, then the Start/Stop function will be activated. It will then be possible for the engine to be auto-stopped but in the event of an auto-stop the Start/Stop function may fail to auto-start the engine due to inadequate capacity in the battery.

The battery must first be charged in order to ensure a successful auto-start after an auto-stop. At an outside temperature of +15 °C the battery needs to be charged for at least 1 hour. At a lower outside temperature a charging time of 3-4 hours is recommended. The recommendation is that the battery is charged using an external battery charger.

If this is not possible then the recommendation is to temporarily deactivate the Start/Stop function until the battery has been adequately recharged.

For more information about recharging the battery, see the section "Battery" in the chapter "Maintenance and service".



Replacing bulbs

General

All bulb specifications are given on page 298.

The following list contains locations of bulbs and other light sources that are specialised or unsuitable for changing except at a workshop:

- Active Xenon headlamps - ABL (Xenon lamps)
- Daytime running lights (DRL) in the spoiler
- Direction indicators, door mirror and approach lighting
- Reading lamps, courtesy lighting and glovebox lighting
- General interior lighting in the roof
- Brake light

WARNING

On cars with Xenon headlamps, the replacement of Xenon lamps must be carried out at a workshop - an authorised Volvo workshop is recommended. Working with Xenon lamps demands extreme caution because the headlamp is equipped with a high voltage unit.

IMPORTANT

Never touch the glass part of the bulbs with your fingers. Grease and oil from your fingers are vaporised by the heat, coating the reflector and then causing damage.

Changing front bulbs

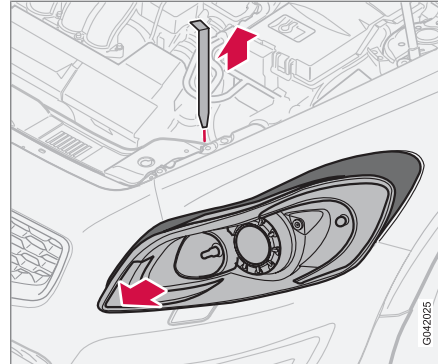

All front bulbs (except for fog lamps) are changed by first removing the lamp housing from the engine compartment.

Removing the lamp housing

1. Remove the remote control key and turn the light switch to position 0.
2. Withdraw the lamp housing's locking pin.

IMPORTANT

Do not pull the electrical cable, only the connector.

3. Pull the lamp housing to the side and then forward.
4. Unplug the connector by pressing down the clip with a thumb while moving out the connector with the other hand.

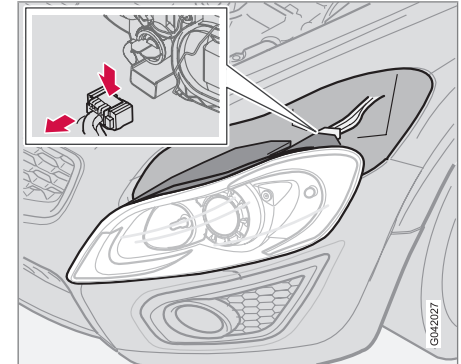

5. Lift out the lamp housing and place it on a soft surface to avoid scratching the lens.

Fitting the lamp housing

1. Plug in the connector and refit the lamp housing and locking pin. Check that the pin is correctly inserted.
2. Check the lighting.

The lamp housing must be plugged in and secured in place before the lighting is switched



Replacing bulbs

on or the remote control key inserted into the ignition switch.

Dipped beam

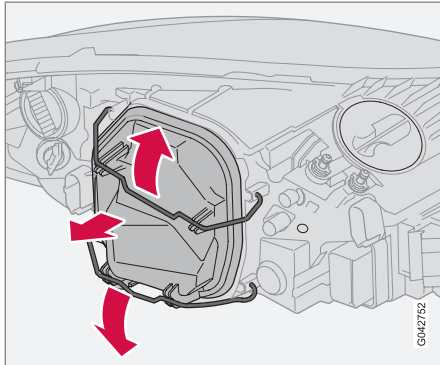

Removing the cover and bulb

1. Remove the entire lamp housing.
2. Bend aside the catches and remove the cover.
3. Release the spring clip securing the bulb. First, press it to the left to release it, then out and down.
4. Pull out the bulb.

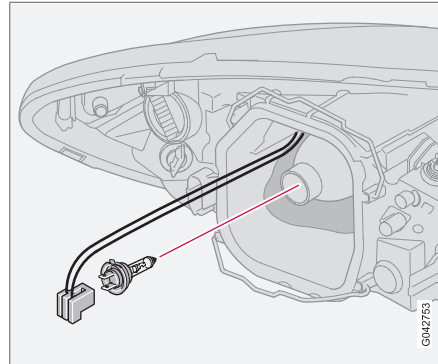

Fitting a new bulb

1. Fit the new bulb. It can only fit in one position.
2. Press the spring clip in/up and then slightly to the right in order to snap it into position.
3. Press the connector back on.
4. Refit the plastic cover.
5. Refit the lamp housing, see page 234.

Main beam

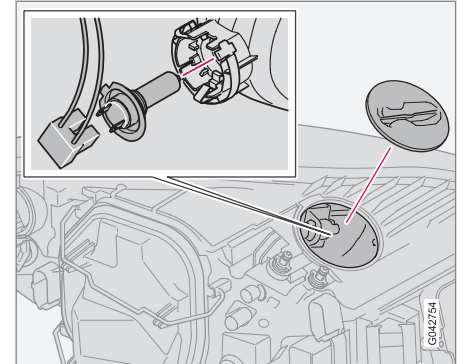

1. Remove the entire lamp housing.
2. Left-hand headlamp:
turn the bulb holder anticlockwise.
Right-hand headlamp:
turn the bulb holder clockwise.
3. Withdraw the bulb holder and change the bulb.
4. Refit the bulb holder. It can only be refitted in one position.
5. Refit the lamp housing.



Replacing bulbs

Position/parking lamps

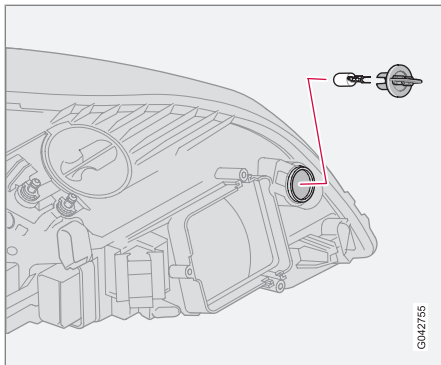

1. Twist the bulb holder anticlockwise and withdraw it. Replace the bulb.
2. Refit the bulb holder. It can only be refitted in one position.

Direction indicators

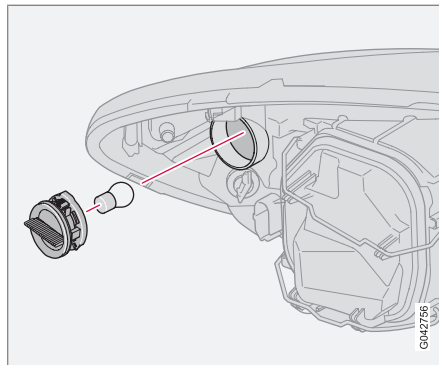

1. Twist the bulb holder anticlockwise and remove it.
2. To remove the bulb from the bulb holder, press the bulb in and turn it anticlockwise.
3. Fit a new bulb and refit the bulb holder into the lamp housing.

Side marker lamps

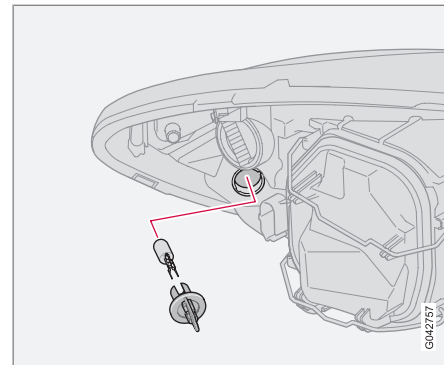

1. Twist the bulb holder anticlockwise and withdraw it. Replace the bulb.
2. Refit the bulb holder. It can only fit in one position.



Replacing bulbs

Front fog lamps

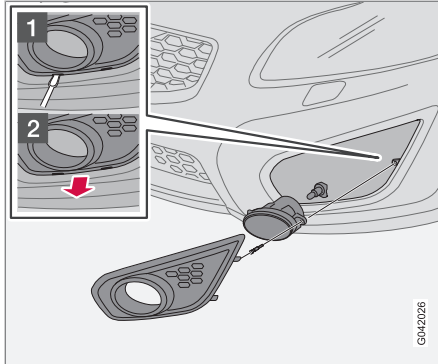

1. Switch off all lights and turn the remote control key to position **0**.
2. Pull the cover straight out in the direction of the centre of the car using a tool, see the illustration above.
 - > Loosen the clips (1) and pull straight out (2).
3. Remove the screw securing the lamp housing and take out the lamp housing.
4. Unplug the connector from the bulb.
5. Turn the bulb anticlockwise and pull it out.
6. Fit the new bulb and turn it clockwise.

7. Refit the bulb holder. The **TOP** mark on the bulb holder must always be upward.
8. Secure the lamp housing with the screw and press the panel back into place.

Removing the bulb holder

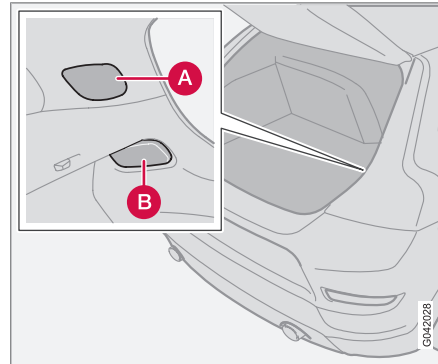

All bulbs in the rear lamp cluster are replaced from inside the cargo area.

1. Switch off all lights and turn the remote control key to position **0**.
2. Remove the cover (A or B) in the left/right-hand panel to access the bulbs.

3. The bulbs are located in separate bulb holders.
4. Unplug the connector from the bulb holder.
5. Press the catches together and pull out the bulb holder.
6. Replace the bulb.
7. Plug in the connector.
8. Press the bulb holder into place and refit the cover (A or B).

i NOTE

If an error message remains after the broken bulb has been replaced then we recommend that you visit an authorised Volvo workshop.



Replacing bulbs

Location of bulbs in the rear bulb holder

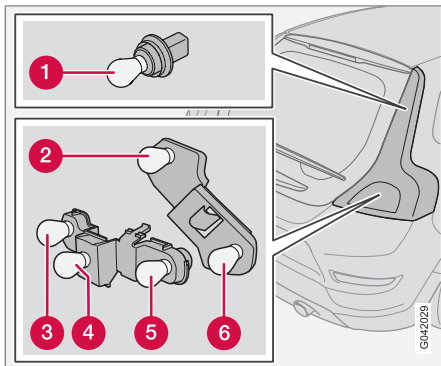

- 1 Brake light
- 2 Position/parking and rear fog lamps
- 3 Position/parking lamps
- 4 Reversing lamp
- 5 Direction indicators
- 6 Position/parking lamps

i NOTE

The rear fog lamp only illuminates in the left rear light cluster on a left-hand drive car and in the right on a right-hand drive.

Number plate lighting

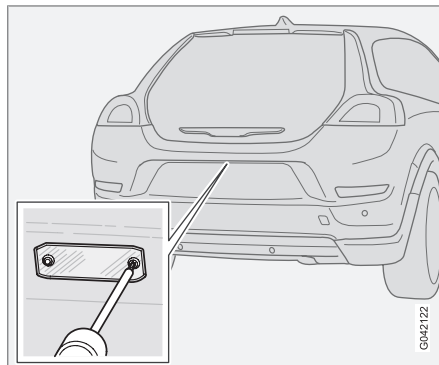

1. Switch off all lights and turn the remote control key to position 0.
2. Remove the screws with a screwdriver.
3. Detach the lens carefully.
4. Replace the bulb.
5. Refit and screw in the lens.

Cargo area

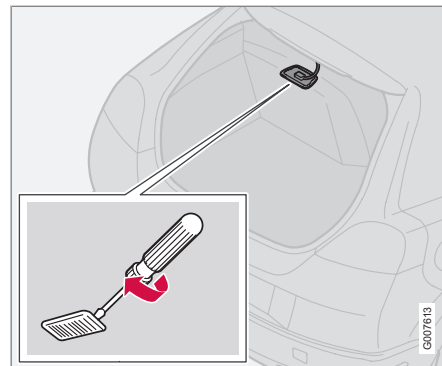

1. Insert a screwdriver and gently turn so that the lamp housing comes loose.
2. Remove the blown bulb.
3. Fit a new bulb.



Replacing bulbs

Passenger compartment lighting in cargo area

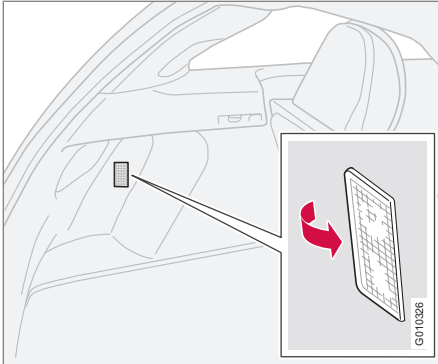

Cargo area lighting also includes a further lamp on the left-hand side of the cargo area.

1. Insert a screwdriver and gently turn so that the lens detaches.
2. Unplug the connector from the bulb holder.

Vanity mirror lighting*

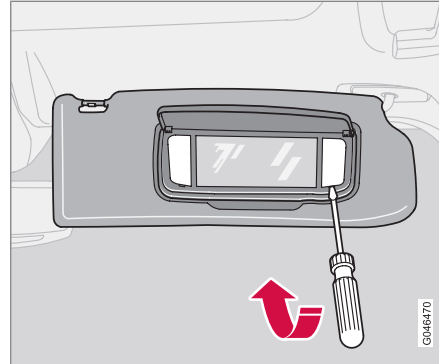

Removal of lamp lens

1. Insert a screwdriver under the lamp lens and gently prize up the lock lugs on the edge.
2. Snap off the lamp lens.
3. Use needle-nose pliers to pull the bulb straight out to the side and replace with a new one. Note! - Do not pinch hard with the pliers. Otherwise the lamp lens could then be crushed.

Attaching the lamp lens

1. Refit the lamp lens.
2. Press it into place.



Fuses

General

All electrical functions and components are fused to protect the car's electrical system from damage by short circuiting and overloading.

The fuses are in two different locations in the car:

- Relay/Fuse box in the engine compartment.
- Relay/Fuse box in the passenger compartment.

Changing

If an electrical component or function does not work, it may be because the component's fuse was temporarily overloaded and blew.

1. Look in the fuse diagram to locate the fuse.
2. Pull out the fuse and check from the side to see whether the curved wire has blown.
3. If this is the case, replace it with a new fuse of the same colour and amperage.

Each fuse box has space for several spare fuses. If the same fuse fails repeatedly then there is a fault in the component. In which case, Volvo recommends that you visit an authorised Volvo workshop for this to be checked.



WARNING

Never use a foreign object, or a fuse with an amperage higher than that specified when replacing a fuse. This could cause significant damage to the electrical system and possibly lead to fire.



Relay/fuse box in the engine compartment

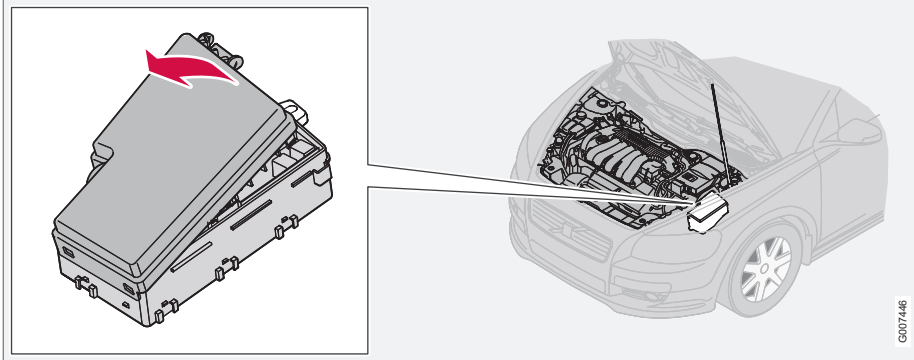

The fuse box has 36 fuse positions. Be sure to replace a blown fuse with a new fuse of the same colour and amperage.

- Fuses 19-36 are of the "Mini Fuse" type.
- Fuses 7-18 are of the "JCASE" type and should be replaced by a workshop.¹

- Fuses 1-6 are of the "Midi Fuse" type and must only be replaced by a workshop.¹

On the inside of the cover there are tweezers that facilitate the procedure for the removal and fitting of fuses.

¹ An authorised Volvo workshop is recommended.



Fuses

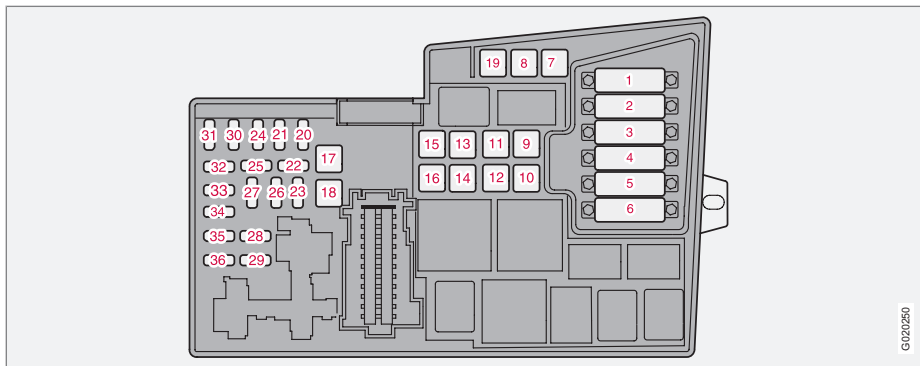

1.	Cooling fan	50 A
2.	Power steering	80 A
3.	Supply to passenger compartment fuse box	60 A
4.	Supply to passenger compartment fuse box	60 A
5.	PTC element, air preheater*	80 A
6.	Glow plugs (D4162T)	60 A
	Glow plugs (5-cyl. diesel)	70 A
7.	ABS pump	40 A

8.	ABS valves	20 A
9.	Engine functions	30 A
10.	Ventilation fan	40 A
11.	Headlamp washers	20 A
12.	Heated rear window	30 A
13.	Actuator solenoid, starter motor	30 A
14.	Trailer wiring*	40 A
15.	Reserve	-

16.	Infotainment system	30 A
17.	Windscreen wipers	30 A
18.	Supply to passenger compartment fuse box	40 A
19.	Reserve	-
20.	Horn	15 A
21.	Fuel-driven additional heater, passenger compartment heater*	20 A
22.	Reserve	-



Fuses

23.	Engine control module (5-cyl. petrol), Transmission control module (5-cyl.)	10 A	32.	Injectors (5-cyl. petrol), Turbo control valve (5-cyl. diesel), Oil level sensor (5-cyl. diesel)	10 A	35.	Relay coil, relay, climate control system, PTC element, oil trap (5-cyl. petrol), Mass air flow sensor (5-cyl. petrol), Turbo control valve (5-cyl. petrol), Solenoids, variable valve timing (5-cyl. petrol), Injectors (2.0 l petrol), EVAP valve (2.0 l petrol), Valve, air/fuel mixture (2.0 l petrol), Control valve, fuel pressure (5-cyl. diesel), Engine control module (5-cyl. diesel), Engine EGR (D4162T)	15 A
	Transmission control module (4-cyl.)	15 A		Control valve, fuel flow (D4162T), Mass air flow sensor (D4162T), Control motor turbo (D4162T)			Engine control module (petrol, D4162T), Accelerator pedal position sensor, Lambda-sond (5-cyl. diesel)	
24.	Heated fuel filter (5-cyl. diesel), PTC element, oil trap (5-cyl. diesel)	20 A	33.	Vacuum pump (5-cyl. petrol), Relay coil, relay, vacuum pump (5-cyl. petrol), Engine control module (5-cyl. diesel), Heated fuel filter (D4162T)	20 A	36.	Engine control module (petrol, D4162T), Accelerator pedal position sensor, Lambda-sond (5-cyl. diesel)	10 A
25.	Central electronic module (CEM) (Start/Stop)	10 A		34.	Ignition coils (petrol), Pressure switch, climate control system (5-cyl.), Control module, glow plugs (5-cyl. diesel), EGR emission control (5-cyl. diesel), Lambda-sond (D4162T), Engine control module (Start/Stop), Relay coils, relays Start/Stop		10 A	
26.	Ignition switch	15 A						
27.	A/C compressor	10 A						
28.	Reserve	–						
29.	Front fog lamps	15 A						
	Daytime running lights (DRL)*							
30.	Coolant pump (Start/Stop)	10 A						
31.	Voltage regulator, alternator (4-cyl. petrol)	10 A						



Fuses

DRiVe Start/Stop*

For more information on DRiVe Start/Stop - see page 161.

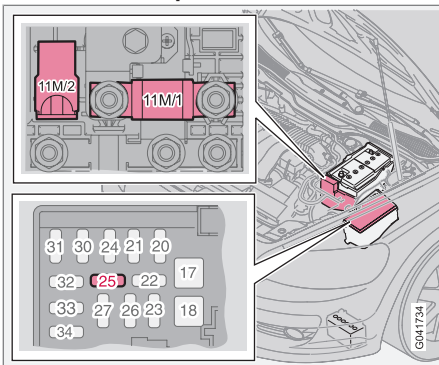

Location of fuses for the Start/Stop function.

No.	Component	A
11M/1	Engine compartment, electrical distribution unit	125
11M/2	Sensor, battery monitoring	15
25	Central electronic module (CEM) (Reference voltage standby battery), diesel engine	10

Relay/Fuse box in the passenger compartment

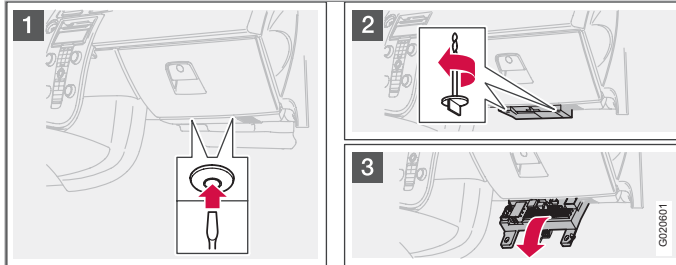

The fuse box has 50 fuse positions. The fuses are located under the glovebox. The box also provides space for several spare fuses. Tools for fuse replacement are located in the relay/fuse box in the engine compartment, see page 241.

Replacing fuses

- 1 Remove the trim concealing the fuse box by pressing in the pin in the centre of the clips (1) about one cm and then withdrawing the clips.
- 2 Turn the two wing screws (that secure the fuse box) (2) anticlockwise and remove them.
- 3 Lower the fuse box (3) half way. Pull it towards the seat until it stops. Lower it completely. The fuse box can be fully unhooked.
4. Close the fuse box in the reverse order.
5. Remove the pins from the centre of the clips. Fit the trim and the clips. Reinsert the pins into the clips. This expands the clips and secures the trim.



Fuses

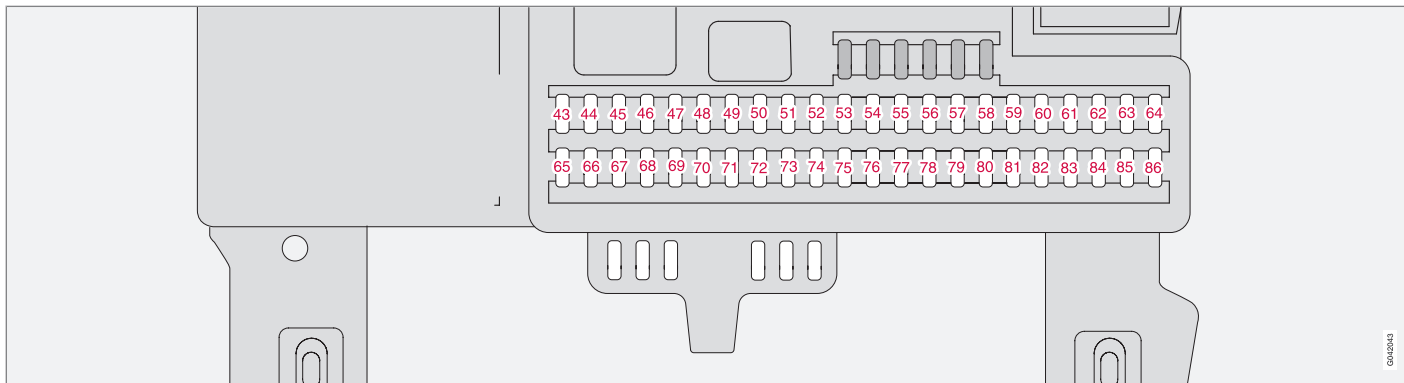

046203

43.	Telematics*, Audio system, RTI*, Bluetooth*	15 A
44.	SRS system, Engine control module (5-cyl, D4162T)	10 A
45.	Electrical socket, passenger compartment	15 A
46.	Passenger compartment, glovebox and courtesy lighting	5 A
47.	Interior lighting, Remote controlled garage door opener*	5 A
48.	Washer, rear window	15 A

49.	SRS system	10 A
50.	Reserve	-
51.	PTC element, air preheater*, Relay coil, relay, heated fuel filter (5-cyl. diesel)	10 A
52.	Transmission control module, ABS system	5 A
53.	Power steering	10 A
54.	Parking assistance*, Xenon*	10 A
55.	Control module Keyless*	20 A

56.	Remote control receiver, Siren*	10 A
57.	Data link connector (DLC), brake light switch	15 A
58.	Main beam, right, Relay coil, relay, auxiliary lamps*	7.5 A
59.	Main beam, left	7.5 A
60.	Seat heating (driver's side)	15 A
61.	Seat heating (passenger side)	15 A
62.	Sunroof*	20 A



Fuses

63.	Reserve	–
64.	Reserve	–
65.	Audio, Infotainment	5 A
66.	Audio, Infotainment, Climate control system	10 A
67.	Reserve	–
68.	Cruise control	5 A
69.	Climate control system, Rain sensor, Buttons for BLIS*, parking assistance*, DRIVE	5 A
70.	Reserve	–
71.	Reserve	–
72.	Reserve	–
73.	Sunroof*, Overhead console for interior lighting, Seatbelt reminder, rear, Dimming, interior rearview mirror*	5 A
74.	Fuel pump	15 A
75.	Reserve	–
76.	Reserve	–
77.	Reserve	–

78.	Reserve	–
79.	Reversing lamp, Dimming, interior rearview mirror (signal)	5 A
80.	Reserve	–
81.	Reserve	–
82.	Supply to front right door	25 A
83.	Supply to front left door	25 A
84.	Power seat, passenger	25 A
85.	Power seat, driver	25 A
86.	Interior lighting, cargo area lighting, power seats, fuel level display (2.0F)	5 A

* Option/accessory, for more information, see Introduction.

General.....	250
Audio functions.....	252
Radio functions.....	257
CD functions.....	262
Menu structure – audio system.....	265
Phone functions*.....	266
Menu structure – phone*.....	273
Bluetooth handsfree*.....	276



10

INFOTAINMENT SYSTEM





10 Infotainment system

General

Infotainment system

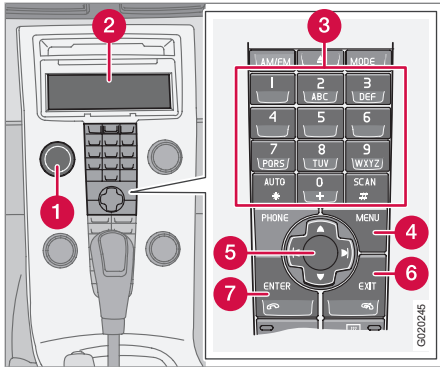

- 1 POWER** - Pushbutton, audio system on/off
- 2** Display
- 3** Keypad
- 4 MENU** - Goes to the menu system
- 5** Navigation buttons
- 6 EXIT** - Exits the menu system
- 7 ENTER** - Selects/activates/deactivates

Infotainment is a system that integrates the audio system and phone*. The infotainment

system can be easily operated using the control panel or the steering wheel keypad*, see page 69. The display (2) shows messages and information on the current function.

Audio system

On/Off

POWER (1) starts/switches off the audio system. If the audio system is active when the remote control key is turned to position **0** then it continues to be active until the remote control key is removed from the ignition switch. The audio system is started automatically the next time the remote control key is turned to position **I**.

Menus

Some infotainment system functions are controlled via a menu system. The current menu level is shown at the top right of the display. Menu options are shown in the middle of the display.

- **MENU** (4) leads to the menu system.
- Up/down with the navigation button (5) moves between menu options.
- **ENTER** (7) selects/activates/deactivates one of the menu options.

- **EXIT** (6) leads back one step in the menu structure. A long press on **EXIT** will exit the menu system.

Shortcuts

Menu options are numbered and can also be selected directly with the keypad (3). So first press **MENU** and then the figure/figures for the desired menu option.

Equipment

The audio system can be equipped with different options and different versions. There are three audio system versions:

- Performance,
- High Performance* or
- Premium Sound*

However, FM radio with RDS, AM radio and CD player are included in all audio systems.



Dolby Surround Pro Logic II^{®1}

Dolby Surround Pro Logic II[®] distributes the two stereo audio channels to left, centre, right and rear speakers. This provides a more realistic sound quality than that provided by standard two-channel stereo.

Dolby Surround Pro Logic II[®] and the Dolby icon  are trademarks of Dolby Laboratories Licensing Corporation.

Dolby Surround Pro Logic II System[®] is manufactured under license from Dolby Laboratories Licensing Corporation.

¹ Premium Sound.



Audio functions

Audio controls

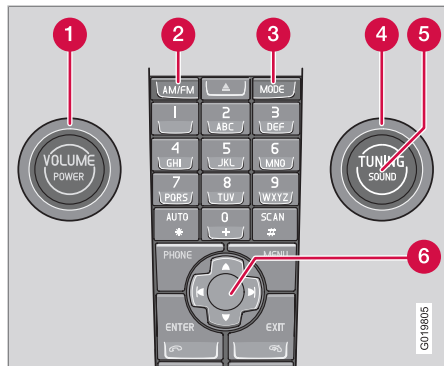

- 1 VOLUME** - Knob
- 2 AM/FM** – Audio source selection
- 3 MODE** - Audio source selection, CD, AUX, USB (e.g. iPod®)¹ and BT*
- 4 TUNING** - Knob
- 5 SOUND** - Button
- 6** Navigation button - Menus

Volume

Use **VOLUME** (1) or the steering wheel keypad to regulate the volume, see page 69. Audio vol-

ume adjusts automatically depending on vehicle speed, see page 255.

Audio source selection

Repeatedly pressing **AM/FM** switches between **FM1**, **FM2** and **AM**.

Repeatedly pressing **MODE** changes between **CD**, **USB**, **AUX** and **BT**.

External audio sources

AUX, USB*

General

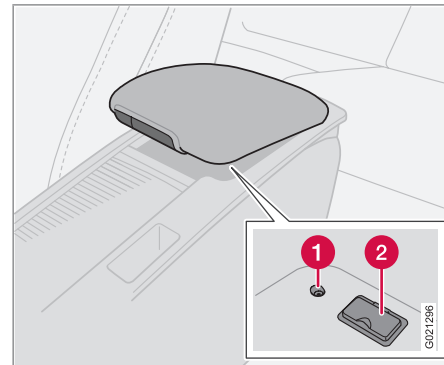

- 1** AUX input
- 2** USB input*

The AUX and USB inputs enable the connection of an external audio source, e.g. an iPod®¹ or MP3 player.

If you choose to connect an iPod®, MP3 player or a USB memory stick to the USB connection then you can control the media via the car's audio controls.

¹ USB only applies for High Performance and Premium Sound. The iPod trademark belongs to Apple Computer Inc.



Audio functions

Use the **MODE** button to select the external audio source you wish to use.

1. If **USB** is selected then **Connect device** is shown in the display.
2. Connect your iPod®, MP3 player or USB memory stick to the USB connection in the centre console's storage compartment (see preceding illustration).
 - > The text **Loading** appears on the display when the system loads the file structure on the storage media. This takes a while.

When the loading is finished the track information is shown on the display and it is possible to select the track required.

Track selection can take place in the following three ways:

- Select **TUNING** (4) clockwise or anticlockwise.
- Use the right or left-hand button (6) of the navigation control to scroll to the desired track.
- With the steering wheel keypad.

In USB or iPod® mode the infotainment system operates in an equivalent way to the CD player for playing back music files. For more information, see page 262.

i NOTE

The system supports the playback of music files in the MP3, WMA and WAV file formats. However, there are variants of these file formats that are not supported by the system. The system also supports most iPod® models produced in 2005 or later. iPod® Shuffle is not supported.

USB memory

To facilitate the use of USB memory avoid storing any files other than music files in the memory. It takes considerably longer for the system to load storage media that contains items other than playable music files.

i NOTE

The system supports removable media which is compatible with USB 2.0 and the FAT32 file system, and can handle a maximum of 500 folders and 64 000 files. The memory must have a capacity of at least 256 Mb.

MP3 player

Many MP3 players have their own file systems that are not supported by the audio system. For use in the system, an MP3 player must be set in **USB Removable device/Mass Storage Device** mode.

iPod®

An iPod® is charged and supplied with power by the USB connection via the player's connection cable. However, if the player's battery is completely discharged then it must be charged before the player is connected.

i NOTE

When an iPod® is used as audio source, the car's infotainment system has a menu structure that is similar to the iPod® player's own menu structure.

AUX

Sometimes the AUX external audio source can be heard at a different volume to the internal audio sources, e.g. the CD player. If the audio volume of the external audio source is too high then the sound quality can be impaired. Prevent this by adjusting the input volume of the AUX input.

i NOTE

The sound quality may be impaired if the player is charged while the audio system is in AUX mode, so avoid charging the player.



Audio functions

Streaming audio via Bluetooth®*

General

If the car is equipped with Bluetooth® hands-free* and a mobile phone is connected then the audio system can wirelessly play back streaming audio files from the mobile phone. Navigation and control of the sound can be carried out via the centre console buttons or via the steering wheel keypad*. In some mobile phones it is also possible to change tracks from the phone.

To be able to play back the audio a device must first be paired and connected to the car. For information about pairing and connection, see page 276. **BT** must also be selected as audio source, see page 252.

NOTE

The Bluetooth® mobile phone must support the Audio/Video Remote Control Profile (AVRCP) and Advanced Audio Distribution Profile (A2DP). The phone should use AVRCP version 1.3, A2DP 1.2. Otherwise some functions may not work.





NOTE

Not all mobile phones available in the market are fully compatible with the Bluetooth® function in the car's audio system. Volvo recommends that you contact an authorised Volvo dealer or visit www.volvocars.com for information on compatible phones and external media players.

Playback

Press the **MODE** button repeatedly in order to select **BT** as audio source.

Audio file selection can take place in the following three ways:

- Select **TUNING** (4) clockwise or anticlockwise.
- Use the  or  button (6) of the navigation control to scroll to the desired audio file.
- With the  or  buttons on the steering wheel keypad.

Audio settings

Adjusting audio settings

Press **SOUND** (5) repeatedly to browse among the following options. Adjust by turning **TUNING**.

- **BASS** - Bass level.
- **TREBLE** - Treble level.
- **FADER** - Balance between the front and rear speakers.
- **BALANCE** - Balance between the left and right-hand speakers.
- **CENTRE**² - Level for centre speaker. Three channel stereo or Pro Logic II® must be activated before adjustment is possible, see under the heading Activating/deactivating surround sound below.
- **SURROUND**² - Level for surround. Pro Logic II® must be activated before adjustment is possible, see under the heading Audio settings below.

² Premium Sound.

* Option/accessory, for more information, see Introduction.



Surround²



Surround settings govern the spatial perception of the sound. Settings and activating/deactivating are separate for each audio source.

The Dolby® icon in the display indicates that Dolby Pro Logic II® is active. There are three different settings for surround sound:

- **Dolby Pro Logic II**
- **3 channel**
- **Off** - 2 channel stereo.

Activating/deactivating surround sound

1. Press **MENU** and then **ENTER**.
2. Scroll to **Audio settings...** and press **ENTER**.
3. Scroll to **Surround FM...**, **Surround AM...**, **Surround CD...** or **Surround AUX...** and press **ENTER**.
4. Scroll to **Dolby Pro Logic II³**, **3 channel** or **Off** and press **ENTER**.

Equalizer front/rear⁴

The equalizer can be used to adjust different frequency bands separately.

Adjusting equalizer

1. Press **MENU** and then **ENTER**.
2. Scroll to **Audio settings...** and press **ENTER**.
3. Scroll to **Equalizer front...** or **Equalizer rear...** and press **ENTER**.
4. The graphic on the display indicates the audio level of the frequency in question.
5. Adjust the level with **TUNING (4)** or up/down with the navigation button. Additional frequencies can be selected using the left/right navigation button.
6. Save with **ENTER** or **EXIT** to exit without saving the settings.

Automatic volume control⁵

The auto volume control function allows the audio volume to increase as the speed of the car increases. There are three levels to choose from: **Low**, **Medium** and **High**.

Adjusting automatic volume control

1. Press **MENU** and then **ENTER**.
2. Scroll to **Audio settings...** and press **ENTER**.
3. Scroll to **Auto. volume control...** and press **ENTER**.
4. Scroll to **Low**, **Medium** or **High** and press **ENTER**.

Optimum sound reproduction

The audio system is calibrated for optimum sound reproduction by means of digital signal processing.

This calibration takes into account loudspeakers, amplifiers, passenger compartment acoustics, listener position etc. for each combination of car model and audio system.

² Premium Sound.

³ Not available in AM and FM mode.

⁴ Certain audio systems.

⁵ Not Performance



10 Infotainment system

Audio functions

There is also a dynamic calibration that takes into account the position of the volume control, radio reception and vehicle speed.

The controls explained in these operating instructions, e.g. bass, treble and equalizer* are only intended for the user to be able to adapt the sound reproduction according to personal taste.

10



Radio functions

Radio controls

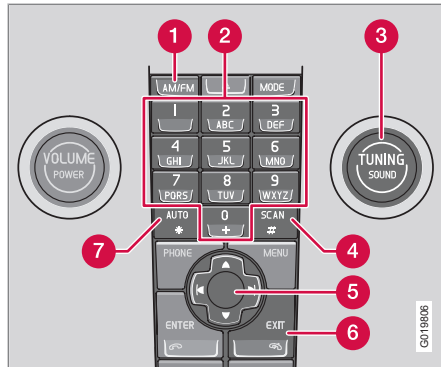

- 1 **FM/AM** – Wavelength selection
- 2 Station presets
- 3 **TUNING** – Knob for station searches
- 4 **SCAN** – Scanning
- 5 Navigation button - Tuning and menus
- 6 **EXIT** - Cancel current function
- 7 **AUTO** – Automatic storage of stations

Tuning

Automatic tuning

1. Select wavelength using **AM/FM** (1).
2. Give a brief press on or .

The radio then automatically searches for the next strong station.

Manual tuning

1. Select wavelength using **AM/FM** (1).
2. Adjust the frequency by turning **TUNING** (3).
- 3).

Tune into a station with a long press on or . Or by using the steering wheel keypad:

- Hold in or on the navigation button depressed until the desired frequency appears on the display.

As long as the frequency graphic appears on the display, searching can be resumed by briefly pressing or .

Storing stations

Ten station presets can be stored per wavelength. FM has two memories for presets: **FM1** and **FM2**. Preset stations are selected using the preset buttons (2) or the steering wheel keypad.

Storing stations manually

1. Tune into a station.
2. Hold a station preset button depressed until the message **Station stored** appears on the display.

Automatic storage of stations

AUTO (7) seeks out the ten strongest radio stations and stores them automatically in a separate memory. The function is especially useful in areas where the radio stations and their frequencies are unfamiliar.

Starting automatic storage of stations

1. Select wavelength using **AM/FM** (1).
2. Hold **AUTO** (7) depressed until **Autostoring** appears on the display.

Once **Autostoring** disappears from the display, the stations are stored. The radio continues in Auto mode and **Auto** appears on the display. The automatically stored presets can now be selected using the preset buttons (2).

Cancelling automatic storage of stations

- Press **EXIT** (6).



Radio functions

Selecting an auto-stored preset

Allowing the radio to remain in Auto mode provides access to the autostored presets.

1. Briefly press **AUTO** (7).
 - > **Auto** appears on the display.
2. Press a preset button (2).
 - > The radio remains in Auto mode until it is exited by a brief press on **AUTO** (7), **EXIT** (6) or **AM/FM** (1) cancels Auto mode.

Storing autostored presets in another memory

An autostored preset can be transferred to the FM or AM memory.

1. Briefly press **AUTO** (7).
 - > **Auto** appears on the display.
2. Press the preset button for the station you want to move.
3. Press the button under which the station will be stored and hold it depressed until the message **Station stored** appears on the display.
 - > The radio exits Auto mode and the stored station can be selected as a preset.

Scanning

SCAN (4) automatically searches through a wavelength for strong stations. When a station is found, it is played for approx. 8 seconds before scanning is resumed.

Activating/deactivating Scan

1. Select wavelength using **AM/FM**.
2. Press **SCAN** to activate.
 - > **SCAN** appears on the display. Close using **SCAN** or **EXIT**.

Storing a station

A selected station can be stored as a preset while **SCAN** is active.

- Press a station preset button and hold it depressed until the message **Station stored** appears on the display.
 - > Scanning is interrupted and the stored station can be selected as a preset.

RDS functions¹

Radio Data System - RDS links FM transmitters into a network. An FM transmitter in such a network sends information that gives an RDS radio the following functions:

- Automatically switches to a stronger transmitter if reception in the area is poor.
- Searches for programme form, such as traffic information or news.
- Receives text information on current radio programme.

Some radio stations do not use RDS or only some if its functionality.

Programme functions

In FM mode, the radio can search for stations with certain programme types. If a required programme type is located the radio can switch stations interrupting the audio source currently in use. For example, if the CD player is in use, it is paused. The interrupting transmission is played at a preset audio volume, see page 261. The radio returns to the previous audio source and audio volume when the set programme type is no longer broadcast.

The programme functions alarm (**ALARM!**), traffic information (**TP**), news (**News**), and pro-

¹ The RDS functions available vary in the different markets.



Radio functions

gramme types (**PTY**) interrupt one another in order of priority, where alarm has the highest priority and programme types has the lowest.

If you want to return to the interrupted audio source before the message or programme type has been completed, press **EXIT**.

For further programme interruption settings, see EON and REG on page 260. The programme functions are modified via the menu system, see page 250.

Alarm

This function is used to warn of serious accidents and catastrophes. The alarm cannot be temporarily interrupted or deactivated. The message **ALARM!** appears on the display when an alarm message is transmitted.

Traffic information – TP



This function allows traffic information broadcast within a set station's RDS network to break through. **TP** shows that the function has been activated. If the set station can send traffic information then **TP** appears on the display.

Activating/deactivating TP

1. Press **MENU** and then **ENTER**.
2. Scroll to **TP** and press **ENTER**.

TP from current station/all stations

The radio can interrupt with traffic information from only the set (current) station or from all stations.

1. Select an FM station.
2. Press **MENU** and then **ENTER**.
3. Scroll to **Advanced radio settings...** and press **ENTER**.
4. Scroll to **TP** and press **ENTER**.
5. Scroll to **TP station...** and press **ENTER**.
 - > Either **TP from current station** or **TP from all stations** is shown on the display.
6. Press **ENTER**.

Activating/deactivating TP search

TP search is useful during long journeys while an audio source other than the radio is being played. The function automatically searches for traffic information within different RDS networks.

1. Press **MENU** and then **ENTER**.
2. Scroll to **Advanced radio settings...** and press **ENTER**.
3. Scroll to **TP** and press **ENTER**.
4. Scroll to **TP search** and press **ENTER**.

News



This function allows news broadcasts within a set station's RDS network to break through. The message **News** shows that the function is active.

Activating/deactivating News

1. Press **MENU** and then **ENTER**.
2. Scroll to **News** and press **ENTER**.

News from current station/all stations

The radio can interrupt with news from only the set (current) station or from all stations.

1. Select an FM station.
2. Press **MENU** and then **ENTER**.
3. Scroll to **Advanced radio settings...** and press **ENTER**.
4. Scroll to **News station...** and press **ENTER**.
 - > Either **News from current station** or **News from all stations** is shown on the display.
5. Press **ENTER**.



Radio functions

Programme types – PTY

PTY The PTY function can be used to select different programme types, such as **Pop music** and **Serious classic**. The PTY symbol indicates that the function is active. This function allows programme types broadcast within a set station's RDS network to break through.

Activating/deactivating PTY

1. Select **FM1** or **FM2** with **FM/AM**.
2. Press **MENU** and then **ENTER**.
3. Scroll to **PTY** and press **ENTER**.
4. Scroll to **Select PTY...** and press **ENTER**.
 - > A list of programme types appears: **Current affairs**, **Information** etc. The PTY function is activated by selecting programme types and deactivated by clearing all PTYs.
5. Select the desired programme types or **Clear all PTY...**

Search PTY

This function searches the entire wavelength for the selected programme type.

1. Activate PTY.
2. Press **MENU** and then **ENTER**.
3. Scroll to **PTY** and press **ENTER**.
4. Scroll to **Search PTY** and press **ENTER**.

If the radio finds any of the selected programme types, **>| To seek** appears on the display. Press the navigation button **▶|** to continue searching for another broadcast of the selected programme types.

Display of programme type

The programme type of the current station can be shown on the display.



NOTE

Not all radio stations support this function.

Activating/deactivating display

1. Press **MENU** and then **ENTER**.
2. Scroll to **PTY** and press **ENTER**.
3. Scroll to **Show PTY** and press **ENTER**.

Radio text

Some RDS stations transmit information on programme content, artists, etc. This information can be shown on the display.

Activating/deactivating radio text

1. Press **MENU** and then **ENTER**.
2. Scroll to **Radio text** and press **ENTER**.

Automatic frequency update – AF

The AF function selects one of the strongest transmitters for a set station. The radio may sometimes need to search through the entire FM wavelength to find a strong transmitter. If this occurs, the radio mutes and **PI seekEXIT to cancel** appears in the display.

Activating/deactivating AF

1. Press **MENU** and then **ENTER**.
2. Scroll to **Advanced radio settings...** and press **ENTER**.
3. Scroll to **AF** and press **ENTER**.

Regional radio programmes – REG



This function causes the radio to continue with a regional transmitter even if its signal strength is low.

Regional indicates that the function is active. The regional function is normally deactivated.

Activating/deactivating REG

1. Press **MENU** and then **ENTER**.
2. Scroll to **Advanced radio settings...** and press **ENTER**.
3. Scroll to **Regional** and press **ENTER**.



Enhanced Other Networks – EON

The EON function is especially useful in urban areas with many regional radio stations. It allows the distance between the car and the radio station transmitter to determine when programme functions should interrupt the current audio source.

- **Local** – interrupts only if the radio station transmitter is close.
- **Distant** – interrupts if the station transmitter is far away, even if there is a lot of static.
- **Off** – no interruption for programmes from other transmitters.

Activating/deactivating EON

1. Press **MENU** and then **ENTER**.
2. Scroll to **Advanced radio settings...** and press **ENTER**.
3. Scroll to **EON...** and press **ENTER**.
4. Scroll to **Local**, **Distant** or **Off** and press **ENTER**.

Resetting RDS functions

Resets all radio settings to the original factory settings.

1. Press **MENU** and then **ENTER**.
2. Scroll to **Advanced radio settings...** and press **ENTER**.
3. Scroll to **Reset all...** and press **ENTER**.

Volume control, programme types

The interrupting programme types are heard at the volume selected for each programme type. If the volume level is adjusted during the programme interruption, the new level is saved until the next programme interruption.



CD functions

CD function controls

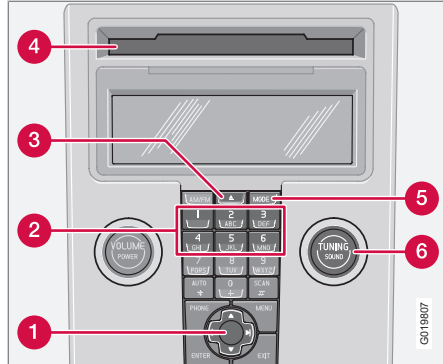

- 1 Navigation button – Fast forward/rewind, track selection and menus
- 2 CD changer position selection*
- 3 CD insertion/eject
- 4 CD insertion/eject slot
- 5 **MODE** - Selection of audio source (CD, AUX, USB*)
- 6 **TUNING** - Knob for track selection

Starting playback (CD player)

If a music CD is in the player when the audio system is in CD mode then playback is started

automatically. Otherwise, load a disc and change to CD mode by pressing **MODE**.

Start playback (CD changer*)

If a CD position with a music CD is already selected when the audio system is activated then playback starts automatically. Otherwise change to CD changer mode using **MODE** and select a disc with the number buttons **1–6** or Up/Down on the navigation button.

Insert a CD

1. Select an empty position with buttons **1–6** or Up/Down on the navigation button.
 - > An empty position is marked on the display. The text **Insert disc** shows that a new disc can be inserted. The CD changer can hold up to 6 CD discs.
2. Inserting a CD in the CD changer.

CD eject

A CD will stay in the ejected position for approx. 12 seconds. Following which it is re-inserted in the player and playback continues.

Eject individual discs by pressing the eject button (3).

Eject all discs with a long press on the eject button. The entire magazine is emptied disc by disc. The message **EJECT ALL** is shown in the display.

Pause

If the volume is turned down completely, the CD player is stopped. The player is restarted when volume is increased.

Audio files*

The CD player/CD changer* also supports MP3 and WMA format audio files.



NOTE

Certain types of copy-protected audio files cannot be read by the player.

When a CD containing audio files is inserted into the player the disc's folder structure is loaded in. It may take a while before playback starts due to the quality of the disc.

Navigation and playback

If a disc with audio files is inserted in the CD player then the disc's folder structure is shown by pressing **ENTER**. The folder structure is navigated in the same way as the audio system's menu structure. Audio files have the symbol and folders have the symbol . Start audio file playback with **ENTER**.

When the playback of a file is finished the playback of the other files in the same folder continues. Folder change takes place automati-



CD functions

cally when all files in the current folder have been played back.

Press left/right on the navigation button if the display is not wide enough to show the whole audio file name.

Fast-wind/change CD tracks and audio files

Short presses right/left on the navigation button are used to scroll between CD tracks/audio files. Long presses are used to fast-wind CD tracks/audio files. **TUNING** (or the steering wheel keypad) can also be used for this purpose.

Scan CD

This function plays the first 10 seconds of each CD track/audio file. Press **SCAN** to activate. Interrupt with **EXIT** or **SCAN** to continue playback of the current CD track/audio file.

Random

This function plays the tracks in random order. The random CD tracks/audio files can be scrolled through in the normal way.

NOTE

It is only possible to scroll between random CD tracks ¹ on the current disc.

Different messages appear on the display depending on which random function has been selected:

- **RANDOM** means that the tracks from only one music CD are played
- **RND ALL** means that all tracks on all music CDs in the CD changer are played.
- **RND FLD** means that the audio files in a folder on the current CD are played.

Activating/deactivating, random (CD player)

If a normal music CD is being played:

1. Press **MENU** and then **ENTER**.
2. Scroll to **Random** and press **ENTER**.

If a disc with audio files is being played:

1. Press **MENU** and then **ENTER**.
2. Scroll to **Random** and press **ENTER**.
3. Scroll to **Folder** or **Disc** and press **ENTER**.

Activating/deactivating, random (CD changer)

If a normal music CD is being played:

1. Press **MENU** and then **ENTER**.
2. Scroll to **Random** and press **ENTER**.
3. Scroll to **Single disc** or **All discs** and press **ENTER**.

The option **All discs** only applies to the music CDs in the changer.

If a CD with audio files is being played:

1. Press **MENU** and then **ENTER**.
2. Scroll to **Random** and press **ENTER**.
3. Scroll to **Single disc** or **Folder** and press **ENTER**.

The function is deactivated when another CD is selected.

Disc text

If title information is stored on a music CD then it can be shown on the display².

Activate/deactivate

1. Start CD playback.
2. Press **MENU** and then **ENTER**.
3. Scroll to **Disc text** and press **ENTER**.

¹ Applies to the CD changer.

² Applies to CD changer.



CD functions

CDs

Using low quality CD discs could result in poor or non-existent sound.



IMPORTANT

Only use standard discs (12 cm in diameter). Do not use CD discs with adhesive disc labels. The heat in the CD player may cause the label to come off, damaging the CD player.



Menu structure – audio system

Overview

FM MENU¹

1. News
2. TP
3. PTY...
4. Radio text
5. Advanced radio settings...
- 6.* Audio settings...

AM MENU

- 1.* Audio settings...

CD MENU

For CD player with CD disc.

1. Random
2. News
3. TP
4. Disc text
- 5.* Audio settings...

CD MENU

For CD player with MP3 disc.

1. Playlist
2. Random...

3. News
4. TP
5. Disc text
- 6.* Audio settings...

CD MENU

For CD changer* with CD disc selected.

1. Random...
2. News
3. TP
4. Disc text
- 5.* Audio settings...

CD MENU

For CD changer* with MP3 disc selected.

1. Playlist
2. Random...
3. News
4. TP
5. Disc text
- 6.* Audio settings...

AUX MENU

1. AUX input volume...
2. News
3. TP
- 4.* Audio settings...

USB MENU*

1. Playlist
2. Random...
3. News
4. TP
5. Track information
6. Audio settings...

¹ The RDS functions available vary in the different markets.



10 Infotainment system

Phone functions*

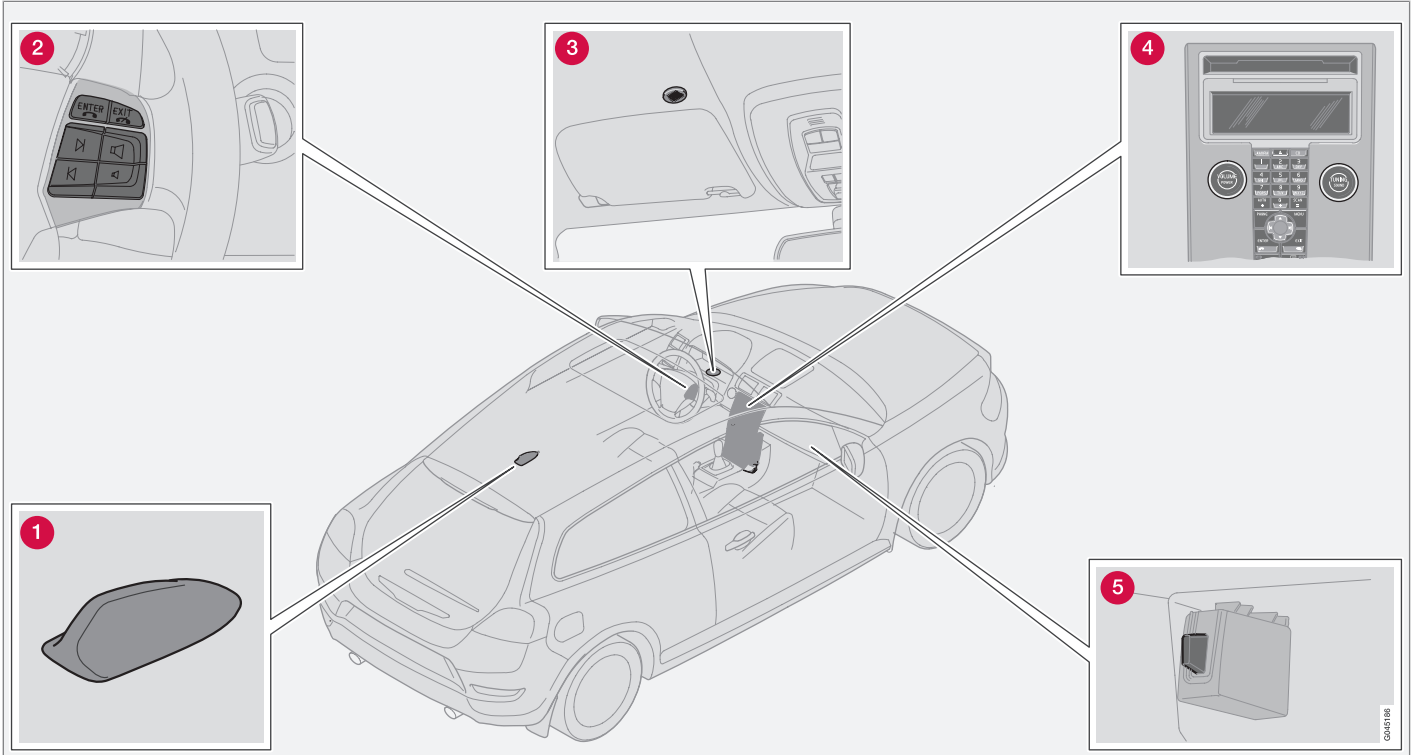

Phone system components.



Phone functions*

Phone system components

- 1 **Antenna¹**
- 2 **Steering wheel keypad.** Most phone system functions can be accessed via the keypad. see page 268.
- 3 **Microphone.** The microphone for hands-free is fitted in the roof by the sun visor.
- 4 **Centre console control panel.** All phone functions (except call volume) can be regulated via the control panel.
- 5 **SIM card reader**

General

- Always put traffic safety first.
- Switch off the phone system when refueling the car.
- Switch off the system near blasting work.
- Volvo recommends that an authorised Volvo workshop carries out phone system servicing.

Emergency calls

Emergency calls to alarm centres can be made without a SIM card as long as there is coverage by a network operator.

Making an emergency call

1. Activate the phone.
2. Ring the emergency number that applies to your region (within EU: 112).
3. Press **ENTER**.

IDIS

With the IDIS system (Intelligent Driver Information System), incoming phone calls and SMS messages can be delayed so that concentration can be focused on driving when IDIS determines that the traffic situation requires a high level of attention.

Incoming calls and SMS messages can be delayed 5 seconds before they are diverted. If the current traffic situation still requires a high level of attention from the driver then the incoming call is diverted to the voice mail. Missed calls are shown in the display.

IDIS be disconnected using menu function 6.5, see page 273.

SIM card

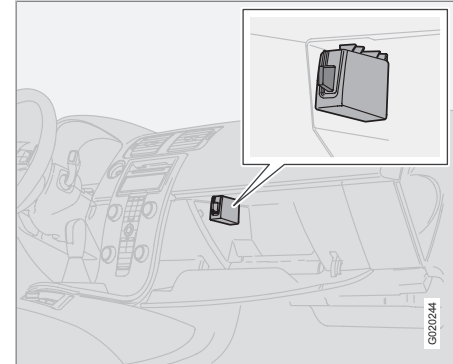

The phone can only be used with a valid SIM card Subscriber Identity Module. Cards are available from various network operators. Contact your network operator if you experience difficulties with the SIM card.

i NOTE

The built-in phone cannot read 3G type SIM cards (3G only). Combined 3G/GSM cards work. Contact your network operator if a replacement SIM card is required.

¹ Available only for built-in phone or RTI.



10 Infotainment system

Phone functions*

Extra SIM card

Many network operators offer two SIM cards for the same phone number. The extra SIM card can be used in the car.

Inserting the SIM card

1. Switch off the phone and open the glove-box.
2. Pull out the SIM card holder from the SIM card reader, see illustration on page 267.
3. Position the SIM card in the holder with the metal surface visible. The bevelled edge of the SIM card should align with the bevel of the SIM card holder.
4. Carefully press in the SIM card holder.

Menus

Page 273 describes how to control phone functions with the menu system.

Traffic safety

For safety reasons, parts of the phone menu system cannot be accessed at speeds in excess of 8 km/h.

Phone controls

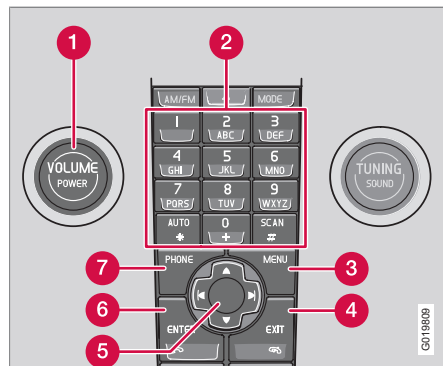

Centre console control panel.

- 1 **VOLUME** - Control the background volume from the radio, for example, during a call
- 2 Number and letter buttons
- 3 **MENU** - Opens the main menu
- 4 **EXIT** - End/refuse calls, clear entered characters
- 5 Navigation button - Scroll in menus and character rows
- 6 **ENTER** - Accept calls. A press of the button reveals latest dialled numbers
- 7 **PHONE** - On/off and standby mode

Steering wheel keypad

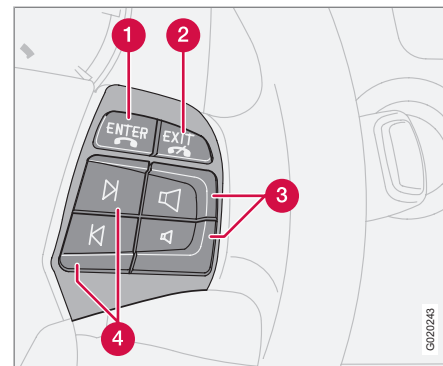

When the phone is active, the steering wheel keypad is locked to phone functions. To control the audio system, the phone must be in standby mode (standby).

- 1 **ENTER** - Accept calls. A press of the button reveals latest calls.
- 2 **EXIT** - End/refuse calls, clear entered characters. Changes between the audio menu and the phone menu.
- 3 Call volume - Increase/decrease
- 4 Navigation buttons - Scroll in menus



Phone functions*

On/Off

A handset appears in the display when the phone system is active or in standby mode (standby). If the remote control key is turned to position **0** when the phone is in one of these modes, the phone automatically resumes this mode the next time the remote control key is turned to position **I** or **II**.

Activating the phone system

Phone system functions can only be used when the phone is in active mode.

1. Press **PHONE**.
2. Enter the PIN code (if necessary) and press **ENTER**.

Deactivating the phone system

No calls can be received when the phone system is deactivated.

- Hold **PHONE** depressed until the phone is deactivated.

Standby mode (standby)

In standby mode, the audio system can be in use while calls are received. However, it is not possible to make calls when in standby mode.

Putting the phone in standby mode

The phone must first be in active mode before it can be put in standby mode.

- Press **PHONE**.

Activating from standby mode

- Press **PHONE**.

Making and receiving calls**To call**

1. Activate the phone system (if necessary).
2. Dial the number or use the phone book, see page 271.
3. Press **ENTER**.

Receiving a call

For Auto answer, see menu option 4.3, see page 273.

- Press **ENTER**.

Ending a call

- Press **EXIT**.

Refusing a call

- Press **EXIT**.

Call waiting

A two-tone signal during a phone call indicates that there is another incoming call. **Answer?** is shown in the display. The call can be refused or taken in the normal manner. If the incoming call is taken, the previous call is put on hold.

Putting a call on hold/resuming a call

1. Press **MENU** or **ENTER**.

2. Scroll to **Hold** or **Resume** and press **ENTER**.

Dialling a third party

1. Put the call on hold.
2. Dial the number of the third party.

Switching between calls

1. Press **MENU** or **ENTER**.
2. Scroll to **Swap** and press **ENTER**.

Starting a conference call

A conference call consists of three parties that can talk to one another. Once a conference call has been initiated, no more parties can be connected. All calls are ended when a conference call is ended.

1. Start two phone calls.
2. Press **MENU** or **ENTER**.
3. Scroll to **Join** and press **ENTER**.





10 Infotainment system

Phone functions*

Volume

The phone uses the driver's door speaker.

Call volume



Call volume is regulated with the steering wheel keypad.

Audio system volume

Audio system volume is temporarily lowered during a phone call. Once the call is ended the previous volume is resumed. If the volume is regulated during the call, the new level is retained once the call is ended. Sound can also be automatically muted during a phone call, see menu 6.4.3, on page 273. This function only applies to the Volvo integrated phone system.

Entering text

Text is entered using the phone keypad.

1. Press the key with the desired character - once for the first character on the button, twice for the second, etc. See table.
2. Press **1** for a space. If two characters in a row are to be entered using the same button, press ***** or wait a few seconds.

A short press on **EXIT** deletes an input character. A long press on **EXIT** will clear all entered characters.

Key	Function
1	space 1 - ? ! , . : " ' ()
2 ABC	a b c 2 ä å à æ ç
3 DEF	d e f 3 è é
4 GHI	g h i 4 i
5 JKL	j k l 5
6 MNO	m n o 6 ñ ö ò Ø
7 PQRS	p q r s 7 ß
8 TUV	t u v 8 ü ù
9 WXYZ	w x y z 9
AUTO *	Pressed briefly if two characters shall be entered after each other with the same key.

Key	Function
0 +	+ 0 @ * # & \$ £ / %
SCAN #	Switch between upper and lower case.

Handling numbers

Calling the last number dialled

The phone automatically stores the last phone numbers dialled.

1. Press **ENTER**.
2. Scroll to a number and press **ENTER**.

Phonebook

If the phone book contains a live caller's contact information then this is shown in the display. Contact information can be stored on the SIM card and in the phone.

Storing contacts in the phone book

1. Press **MENU**.
2. Scroll to **Phone book...** and press **ENTER**.
3. Scroll to **New contact** and press **ENTER**.
4. Enter a name and press **ENTER**.
5. Enter a number and press **ENTER**.

**Phone functions***

6. Scroll to **SIM card** or **Phone memory** and press **ENTER**.

Searching for contacts in the phone book

Use the down arrow of the navigation button instead of **MENU** for direct access to the Search menu.

1. Press **MENU**.
2. Scroll to **Phone book...** and press **ENTER**.
3. Scroll to **Search** and press **ENTER**.
4. Enter the first few letters of the item and press **ENTER**, or simply press **ENTER**.
5. Scroll to an item and press **ENTER**.

Copying entries between the SIM card and Phone book

1. Press **MENU**.
2. Scroll to **Phone book...** and press **ENTER**.
3. Scroll to **Copy all...** and press **ENTER**.
4. Scroll to **SIM to phone** or **Phone to SIM** and press **ENTER**.

Deleting contacts from the phone book

1. Press **MENU**.
2. Scroll to **Phone book...** and press **ENTER**.
3. Scroll to **Search** and press **ENTER**.

4. Enter the first few letters of the item and press **ENTER**, or simply press **ENTER**.
5. Scroll to the item to be erased and press **ENTER**.
6. Scroll to **Erase** and press **ENTER**.

Erase all contacts

1. Press **MENU**.
2. Scroll to **Phone book...** and press **ENTER**.
3. Scroll to **Erase SIM** or **Erase phone** and press **ENTER**.

If required, enter phone code. The factory-set default code is 1234.

Speed dial

A keypad button (1–9) can be used as a speed dial number for a contact in the phone book.

1. Press **MENU**.
2. Scroll to **Phone book...** and press **ENTER**.
3. Scroll to **Speed dial...** and press **ENTER**.
4. Scroll to **Select numbers** and press **ENTER**.
5. Scroll to the digit of the keypad button for the speed dial number and press **ENTER**.

6. Enter the first few letters of the item and press **ENTER**, or simply press **ENTER**.
7. Scroll to an item and press **ENTER**.
8. Hold **EXIT** depressed to leave the menu system.

Calling using speed dial

- Briefly press the required keypad button, followed by **ENTER**.

 NOTE

It takes a short time before speed dialling becomes available after the phone has been activated.

To use the speed dial function **Speed dial...** must be activated in the **Phone book...** menu, see page 275.

Calling from the phone book

1. Press **MENU**.
2. Scroll to **Phone book...** and press **ENTER**.
 - > All contacts in the phone book memory are displayed. The number of contacts displayed can be reduced by entering part of the contact's name.
3. Scroll to a contact and press **ENTER**.



Phone functions*

NOTE

Press **ENTER** to dial.

NOTE

Hold in the required letter/button in the keypad for about 2 seconds to reach the corresponding letter in the phone book.

Functions during a call

Several functions are available during a call. Some functions can only be used when a call is on hold.

Press **MENU** or **ENTER** during a call to access the In-call menu and scroll to one of the following alternatives:

1. **Mute microphone/Microphone on** – Mute mode.
2. **Hold/Resume** - Put a call on hold or resume a call.
3. **Phone book** – Show phone book.
4. **Join** – – Conference calling (available if more than two parties are connected).
5. **Swap** – Switch between two calls (available if up to three parties are connected).

SMS - Short Message Service

Reading SMS

1. Press **MENU**.
2. Scroll to **Messages...** and press **ENTER**.
3. Scroll to **Read** and press **ENTER**.
4. Scroll to a message and press **ENTER**.
 - > The message text is shown in the display. Additional selections can be made by pressing **ENTER**. Hold **EXIT** depressed to leave the menu system.

Writing and sending

1. Press **MENU**.
2. Scroll to **Messages...** and press **ENTER**.
3. Scroll to **Write new** and press **ENTER**.
4. Enter text and press **ENTER**.
5. Scroll to **Send** and press **ENTER**.
6. Enter a phone number and press **ENTER**.

IMEI number

To block the phone, you must provide your network operator with the phone's IMEI number. This is a 15 digit serial number that is programmed into the phone. Dial *#06# to show this number in the display. Write it down and keep it in a safe place.

Specifications

Output	2 W
SIM card	Small
Memory entries	250 ^A
SMS (Short Message Service)	Yes
Data/Fax	No
Dualband (900/1800 MHz)	Yes

^A In the phone, plus the number of memory spaces that are available on the SIM card.

**Menu structure – phone*****Phone menu****1. Call register...**

- 1.1. Last 10 missed calls
- 1.2. Last 10 received calls
- 1.3. Last 10 dialled calls
- 1.4. Erase list...
 - 1.4.1. All calls
 - 1.4.2. Missed calls
 - 1.4.3. Received calls
 - 1.4.4. Dialled numbers
- 1.5. Call duration...
 - 1.5.1. Last call
 - 1.5.2. Call count
 - 1.5.3. Total time
 - 1.5.4. Reset timers

2. Phone book...

- 2.1. Search
- 2.2. New contact
- 2.3. Copy all...
 - 2.3.1. SIM to phone
 - 2.3.2. Phone to SIM

2.4. Speed dial...

- 2.4.1. Active
- 2.4.2. Select numbers

2.5. Erase SIM

2.6. Erase phone

2.7. Memory status

3. Messages...

- 3.1. Read
- 3.2. Write new
- 3.3. Message settings...
 - 3.3.1. SMSC number
 - 3.3.2. Validity time...
 - 3.3.3. Message type...

4. Call options...

- 4.1. Send my number
- 4.2. Call waiting
- 4.3. Automatic answer
- 4.4. Auto re-dial
- 4.5. Voice mail number
- 4.6. Diversions...
 - 4.6.1. All calls

4.6.2. When busy

4.6.3. Not answered

4.6.4. Not reachable

4.6.5. Fax calls

4.6.6. Data calls

4.6.7. Cancel all

5. Change phone

- 5.1. Carphone
- 5.2. Add phone
- 5.3. Added phones¹

**NOTE**

The menu above only applies to cars with Bluetooth™ handsfree.

6. Phone settings...

- 6.1. Network selection...
 - 6.1.1. Automatic
 - 6.1.2. Manual select
- 6.2. SIM security...
 - 6.2.1. On
 - 6.2.2. Off

¹ A maximum of 3 phones.



Menu structure – phone*

- 6.2.3. Automatic
- 6.3. Edit PIN code
- 6.4. Sounds and volume...
 - 6.4.1. Ring volume
 - 6.4.2. Ring signals...
 - 6.4.3. Mute radio
 - 6.4.4. Message beep
- 6.5. IDIS
- 6.6. Reset phone settings

- 1.4.1. All calls
- 1.4.2. Missed calls
- 1.4.3. Received calls
- 1.4.4. Dialed numbers

1.5. Call duration
Duration of all calls or of the most recent call.
To reset the call timer, see menu 1.5.4.

- 1.5.1. Last call
- 1.5.2. Call count
- 1.5.3. Total time
- 1.5.4. Reset timers

2. Phone book

- 2.1. Search
Search for a name in the phone book.
- 2.2. New contact
Store names and phone numbers in the phone book, see page 270.
- 2.3. Copy all
Copy phone numbers and names from the SIM card to the phone memory.
- 2.3.1. SIM to phone
- 2.3.2. Phone to SIM

2.4. Speed dial

A number stored in the phone book can be stored as a speed dial number.

- 2.4.1. Active
- 2.4.2. Select numbers

2.5. Erase SIM

Erase the entire SIM card memory.

2.6. Erase phone

Erase the entire phone memory.

2.7. Memory status

Shows how many positions are occupied in the SIM card and phone memory. The table shows how many of the total number of positions are occupied, e.g. 100 (250).

3. Messages

3.1. Read

Received text messages. Select whether to erase, forward, change or save the entire message or parts of it.

3.2. Write new

Write a message using the keypad. Choose whether to save or send it.

3.3. Message settings

Enter the number (SMSC number) of the message centre to which messages are to be transferred as well as how long they are to be saved at the message centre. Contact your network

Description of menu options

1. Call register

1.1. Last 10 missed

List of missed calls. You can choose to call, erase or store the number in the phone book.

1.2. Last 10 received

List of received calls. You can choose to call, erase or store the number in the phone book.

1.3. Last 10 dialed

List of dialed numbers. You can choose to call, erase or store the number in the phone book.

1.4. Erase list

Erase the lists found in the menus 1.1, 1.2 and 1.3 as below.



Menu structure – phone*

operator for information on message settings. Normally, these settings should not be altered.

- 3.3.1. **SMSC number**
- 3.3.2. **Validity time...**
- 3.3.3. **Message type...**

4. Call settings

4.1. Send my number

Displays or hides your phone number to/from the person you call. Contact your network operator regarding ex-directory numbers.

4.2. Call waiting

Be alerted during a phone call that there is another incoming call.

4.3. Auto answer

Automatically answers incoming calls.

4.4. Auto redial

Automatically calls a previously engaged number.

4.5. Voice mail number

Stores voice mail number.

4.6. Call divert

Choose when and what type of calls are to be diverted to a specified phone number.

4.6.1. All calls

This setting only applies during the call in progress.

4.6.2. When busy

4.6.3. Not answered

4.6.4. Not reachable

4.6.5. Fax calls

4.6.6. Data calls

4.6.7. Cancel all

5. Change phone

5.1. Car phone

Select the built-in phone.

5.2. Add phone

Add mobile phones to the list Added phones.

5.3. Added phones

Select to connect to one of the added phones (up to 3 phones).



NOTE

The menu above only applies to cars with Bluetooth™ handsfree.

6. Phone settings

6.1. Selecting network

Choose a network automatically or manually. The selected network is shown in the display in the phone's basic mode.

6.1.1. Automatic

6.1.2. Manual select

6.2. SIM security

Select if the PIN code should be on, off or if the phone should automatically give the PIN code.

6.2.1. On

6.2.2. Off

6.2.3. Automatic

6.3. Edit PIN code

Change PIN code. Write down and save the code in a safe place.

6.4. Sounds and volume

6.4.1. Ring volume

Adjust the ring tone volume.

6.4.2. Ring signals...

There are seven different ring tones.

6.4.3. Mute radio

The radio can be switched off/on.

6.4.4. Message beep

6.5. IDIS

If the IDIS function is deactivated, incoming calls are not delayed, regardless of the driving situation.

6.6. Reset phone settings

Reset the system's factory settings.



Bluetooth handsfree*

General

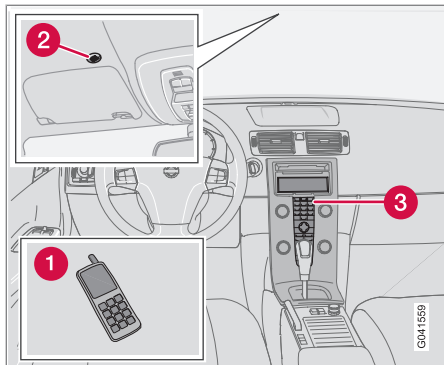

System overview.

- 1 Mobile phone
- 2 Microphone
- 3 Centre console

Bluetooth™

A mobile phone equipped with Bluetooth™ can be connected wirelessly to the audio system. The audio system then works handsfree, with the option to control a range of the mobile phone's functions remotely. The microphone is fitted in the roof console (2). The mobile phone can always be operated by its own keys irrespective of whether or not it is connected.

NOTE

Only a selection of mobile phones are fully compatible with the handsfree function. Volvo recommends that you seek assistance from an authorised Volvo dealer or visit www.volvocars.com for information on compatible phones.

Menus and controls

The menus are navigated using the control panel in the centre console (3), see page 268.

Remember

The menus are controlled from the centre console and the steering wheel keypad. For general information on menus, see page 273.

NOTE

If the car is equipped with both Bluetooth™ handsfree and built-in phone then there is an additional menu in the phone menu, see page 273.

Activate/deactivate

A short press on **PHONE** activates the handsfree function. The text **PHONE** at the top of the display shows that it is in phone mode. The symbol  shows that the handsfree function is active.

One long press on **PHONE** deactivates the handsfree function and disconnects a connected phone.

Connect mobile phone

A mobile phone is connected in different ways depending on whether or not it has been connected previously. To connect a mobile phone for the first time, follow the instructions below:

Alternative 1 - via the car's menu system

1. Make the mobile phone detectable/visible via Bluetooth™, see the mobile phone's manual or www.volvocars.com.
2. Activate the handsfree function with **PHONE**.
 - > Menu option **Add phone** appears on the display. If one or more mobile phones have already been registered then these are also shown.
3. Select **Add phone**.
 - > The audio system searches for mobile phones in the vicinity. The search takes approximately 30 seconds. The mobile phones detected are specified with their respective Bluetooth™ name in the display. The handsfree function's Bluetooth™ name is shown in the mobile phone as **My Volvo Car**.



Bluetooth handsfree*

- Choose one of the mobile phones in the audio system display.
- Enter the number series shown in the audio system display via the mobile phone keypad.

Alternative 2 - via the phone's menu system

- Activate the handsfree function with **PHONE**. If there is a phone connected, disconnect the connected phone.
- Search with the phone's Bluetooth™, see the mobile phone's manual.
- Select **My Volvo Car** in the list of units detected in your mobile phone.
- Enter the PIN code '1234' into the mobile phone when prompted for the PIN code.
- Select to connect to **My Volvo Car** from the mobile phone.

The mobile phone is registered and connected automatically to the audio system while the text **Synchronising** is shown in the display. For more information on how mobile phones are registered, see page 278.

When the connection is established the symbol  is shown and the mobile phone's Bluetooth™ name is shown in the display. Now

the mobile phone can be controlled from the audio system.

To call

- Make sure that the text **PHONE** is shown at the top of the display and that the  symbol is visible.
- Dial the number or use the phone book, see page 279.
- Press **ENTER**.

The call is interrupted with **EXIT**.

Disconnecting the mobile phone

Automatic disconnection takes place if the mobile phone moves out of the audio system's range. For more information on connection, see page 278.

Manual disconnection takes place by deactivating the handsfree function with one long press on **PHONE**. The handsfree function is also deactivated when the engine is switched off or when a door is opened¹.

When the mobile phone has been disconnected an ongoing call can be continued with the mobile phone's built-in microphone and speaker.

NOTE

Some mobile phones require that the transfer from handsfree is confirmed from the mobile phone's keypad.

10

Making and receiving calls**Incoming call**

Calls are accepted with **ENTER** even if the audio system is in CD or FM mode for example. Refuse or end with **EXIT**.

Auto answer

The automatic answer function means that calls are accepted automatically. Activate/deactivate under **Phone Menu... → Call options... → Automatic answer**.

In-call menu

Press **MENU** or **ENTER** during an ongoing call to access the following functions:

- Mute microphone** - audio system microphone is muted.
- Transfer call to mobile** - the call is transferred to the mobile phone.

¹ Applies to Keyless Drive.



Bluetooth handsfree*

NOTE

With certain mobile phones the connection is terminated when the privacy function is used. This is normal. The handsfree function asks if you want to reconnect.

- **Phone book** – searching in the phone book.

NOTE

A new call cannot be started during an ongoing call.

Audio settings

Call volume

Call volume can be adjusted during calls. Use the steering wheel keypad.

Audio system volume

In phone mode (**PHONE**) the audio system volume can be adjusted as usual with **VOLUME**.

The audio source can be automatically muted for incoming calls under **Phone Menu... → Phone settings... → Sounds and volume... → Mute radio**.

Ring volume

Go to **Phone Menu... → Phone settings... → Sounds and volume... → Ring volume** and adjust with  /  on the navigation button.

Ring signals

The handsfree function has integrated ring signals that can be selected under **Phone Menu... → Phone settings... → Sounds and volume... → Ring signals... → Ring signal 1** etc.

NOTE

The connected mobile phone's ring signal is not deactivated when one of the handsfree system's integrated signals is used.

In order to select the connected phone's ring signal², go to **Phone Menu... → Phone settings... → Sounds and volume... → Ring signals... → Use mobile phone signal**.

More on registering and connecting

A maximum of 3 mobile phones can be registered. Registration is performed once per phone. After registration the mobile phone is in the list of added phones. Not more than one mobile phone can be connected at a time. Phones can be deregistered under **Phone Menu... → Bluetooth... → Remove phone**.

Automatic connection

When the handsfree function is active and the last mobile phone connected is in range it is connected automatically. When the audio system searches for the last phone connected its name is shown in the display. To change over to manual connection of another phone, press **EXIT**.

Manual connection

If you want to connect a mobile phone other than the last connected or change the connected mobile phone, proceed as follows:

Set the audio system in phone mode (**PHONE**) and follow the instructions on the display or change the connected mobile phone by using the menu system as described below.

The menu structure is available in two variants depending on whether the car only has

² Not supported by all mobile phones.

* Option/accessory, for more information, see Introduction.



Bluetooth handsfree*

Bluetooth™ or if the car also has a built-in phone.

- For cars with only Bluetooth™ the connection is made under **Phone Menu... → Bluetooth... → Change phone → Add phone** or select one of the previously connected phones.
- For cars with built-in phone and Bluetooth™ the connection is made under **Phone Menu... → Change phone → Add phone** or select one of the previously connected phones.

Phonebook

All use of the phone book presupposes that the text **PHONE** is shown at the top of the display and that the  symbol is visible.

The audio system stores a copy of the phone book from each registered mobile phone. The phone book is copied automatically to the audio system during each connection. Deactivate the function under **Phone settings... → Synchronise phone book**. Searching for contacts is only performed in the connected mobile phone's phone book.





NOTE

If the mobile phone does not support copying of the phone book then **List is empty** is shown when copying is finished.

If the phone book contains a ringing caller's contact information then this is shown in the display.

Searching for contacts

The easiest way to search in the phone book is with long presses on the keys **2-9**. This starts a search in the phone book based on the key's first letter.

The phone book can also be reached with  /  on the navigation button or with  /  on the steering wheel keypad. The search can also be performed from the phone book's Search menu under **Phone book... → Search**:

1. Enter the first few letters of the contact and press **ENTER**. Or simply press **ENTER**.
2. Scroll to a contact and press **ENTER** to call.

Voice recognition

The mobile phone's voice recognition function for dialling can be used by holding in **ENTER**.

NOTE

Only a selection of mobile phones are fully compatible with the voice recognition function. Volvo recommends that you contact an authorised Volvo dealer or visit www.volvocars.com for information on compatible phones.

Voice mail number

The number to the voice mail is changed under **Call options... → Voice mail number**. If no number is stored then this menu is reached with one long press on **1**. Press **1** for a long time to use the stored number.

Call lists

The call lists are copied to the handsfree function at each new connection and are then updated during the connection. Press **ENTER** to show the last dialled. Other call lists are available under **Call register...**

NOTE

Certain mobile phones show a list of the last dialled numbers in reverse order.



Inputting text

Input text using the keypad in the centre console. Press once for the key's first character,



Bluetooth handsfree*

twice for the second etc. Continue pressing for more characters, see the table on page 270.

A short press on **EXIT** deletes an input character. One long press on **EXIT** clears all input characters.  /  on the navigation button scrolls between the characters.

Menu structure - Bluetooth™handsfree

NOTE

The menu for Bluetooth™handsfree is available in two variants. For cars with only Bluetooth™handsfree and for cars with built-in phone and Bluetooth™handsfree.

1. **Call register...**
 - 1.1. Last 10 missed calls
 - 1.2. Last 10 received calls
 - 1.3. Last 10 dialled calls
2. **Phone book...**
 - 2.1. Search
 - 2.2. Copy fr. mobile phone

3. **Bluetooth...**
 - 3.1. Change phone
 - 3.1.1. Add phone
 - 3.1.2. Added phones³
 - 3.2. Remove phone
 - 3.3. Connect fr. mobile phone
 - 3.4. Car Bluetooth info
4. **Call options...**
 - 4.1. Automatic answer
 - 4.2. Voice mail number
5. **Phone settings...**
 - 5.1. Sounds and volume...
 - 5.1.1. Ring volume
 - 5.1.2. Ring signals...
 - 5.1.3. Mute radio
 - 5.2. Synchronise phone book

Menu structure - Bluetooth™handsfree with built-in phone

1. **Call register...**
 - 1.1. Last 10 missed calls
 - 1.2. Last 10 received calls
 - 1.3. Last 10 dialled calls
2. **Phone book...**
 - 2.1. Search
 - 2.2. Copy fr. mobile phone
3. **Bluetooth...**
 - 3.1. Remove phone
 - 3.2. Connect fr. mobile phone
 - 3.3. Car Bluetooth info
4. **Call options...**
 - 4.1. Automatic answer
 - 4.2. Voice mail number
5. **Change phone**
 - 5.1. Carphone
 - 5.2. Add phone
 - 5.3. Added phones³

³ A maximum of 3 phones.



Bluetooth handsfree*

6. Phone settings...

- 6.1. Sounds and volume...
 - 6.1.1. Ring volume
 - 6.1.2. Ring signals...
 - 6.1.3. Mute radio
- 6.2. Synchronise phone book

Type designation.....	284
Dimensions and weights.....	286
Engine specifications.....	289
Engine oil.....	290
Fluids and lubricants.....	292
Fuel.....	295
Wheel and tyres, dimensions and pressure	296
Electrical system.....	298
Type approval.....	300
Symbols in the display.....	301



11

SPECIFICATIONS

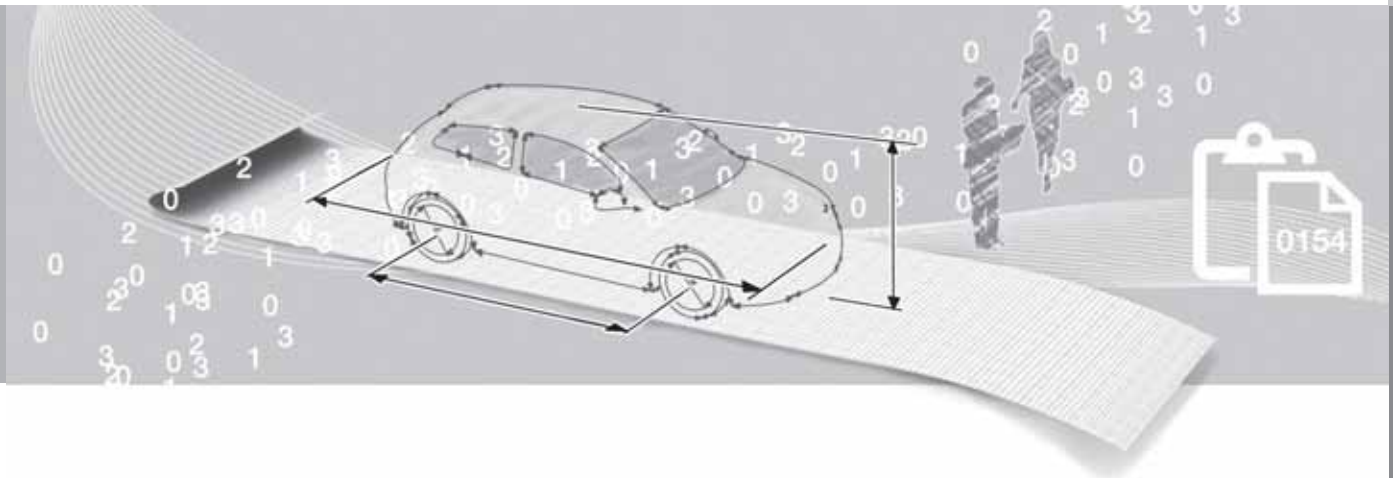

11 Specifications

Type designation

11

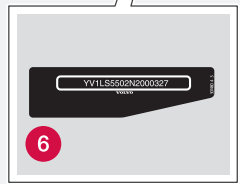
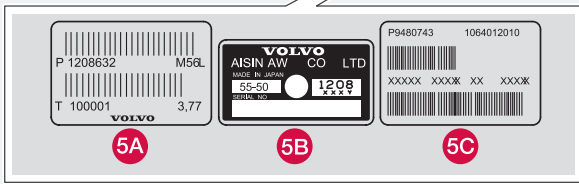
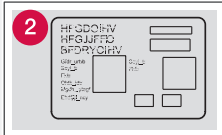
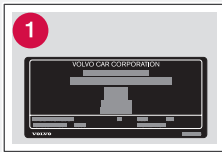
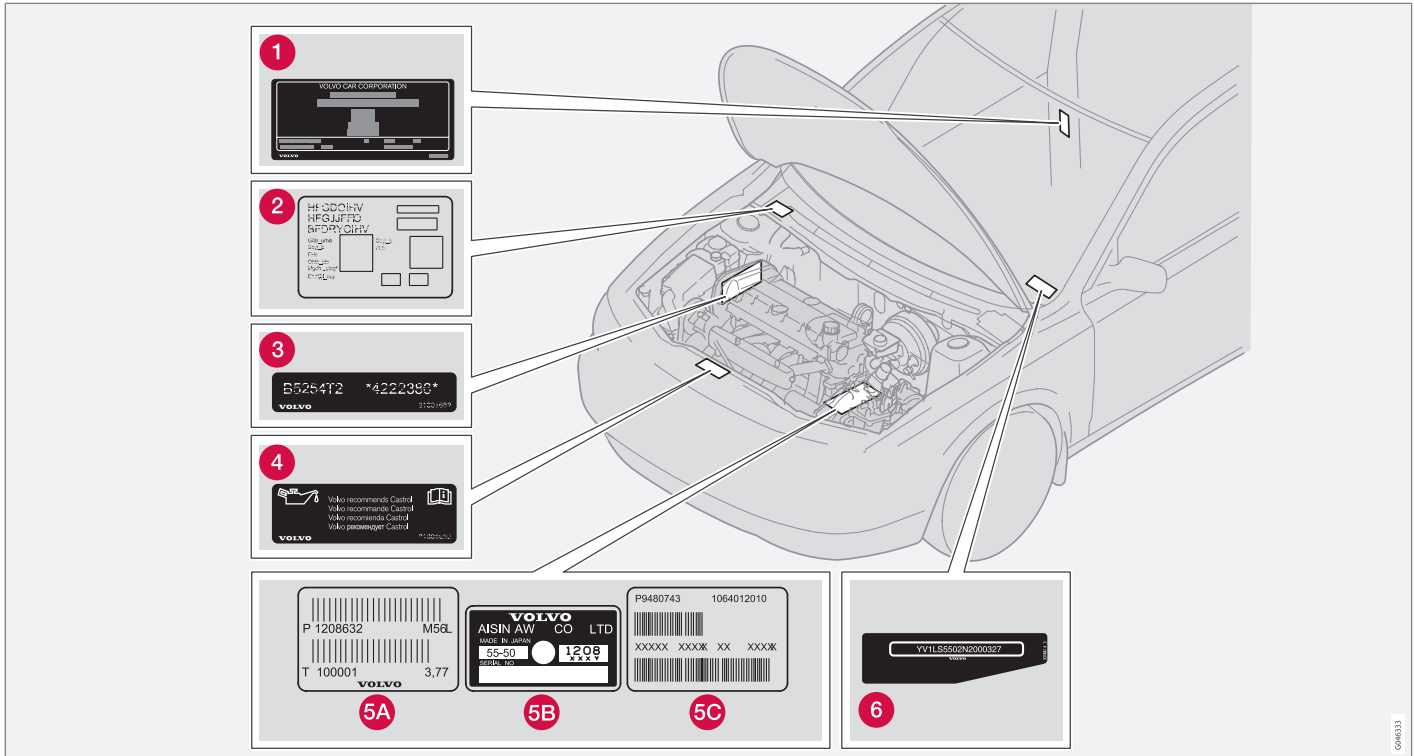

GM48331

Type designation

Knowing the car's type designation, vehicle identification and engine numbers can facilitate all contact with a Volvo dealer regarding the car and when ordering spare parts and accessories.

- 1 Type designation, vehicle identification number, maximum permissible weights, codes for colour and upholstery and type approval number. The label is visible when the right door is opened.
- 2 Label for parking heater.
- 3 Engine code and engine serial number.
- 4 Label for engine oil.
- 5 Gearbox type designation and serial number:
 - A manual gearbox
 - B, C automatic gearbox
- 6 The car's identification number (VIN – Vehicle Identification Number).

Further information on the car is presented in the registration document.

i NOTE

The labels shown in the owner's manual are not provided as exact reproductions of those in the car. The purpose is to show their approximate appearance and location in the car. The information that applies to your car in particular is available on the label in question in your car.

11 Specifications

Dimensions and weights

Dimensions

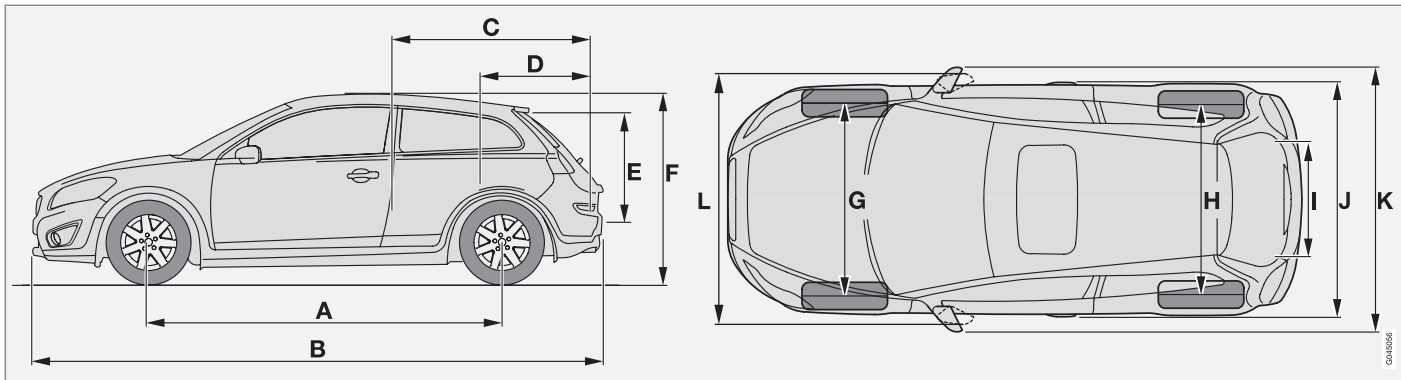

	Dimensions	mm
A	Wheelbase	2640
B	Length	4266
C	Load length, floor, folded seat	1486
D	Load length, floor	663
E	Load height	642
F	Height	1447

	Dimensions	mm
G	Front track	1548 ^A
		1535 ^B
H	Rear track	1544 ^A
		1531 ^B
I	Load width, floor	713
J	Width	1782 (1797 ^C)

	Dimensions	mm
K	Width including door mirrors	2039
L	Width including folded-in door mirrors	1871

A with 15" wheel
 B with 16" and 17" wheels
 C with Keyless drive*

046026

Dimensions and weights

Weights

Kerb weight includes the driver, the fuel tank 90% full and all fluids.

The weight of passengers and accessories, and towball load (when a trailer is hitched, see table) influences the payload and is not included in the kerb weight.

Permitted maximum load = Gross vehicle weight - Kerb weight.

NOTE

The documented kerb weight applies to cars in the standard version - i.e. a car without extra equipment or accessories. This means that for every accessory added the loading capacity of the car is reduced correspondingly by the weight of the accessory.

Examples of accessories that reduce loading capacity are the Kinetic/Momentum/Summum equipment levels, as well as other accessories such as Towbar, Load carriers, Space box, Audio system, Auxiliary lamps, GPS, Fuel-driven heater, Safety grille, Carpets, Cargo cover, Power seats, etc.

Weighing the car is a certain way of ascertaining the kerb weight of your own particular car.

WARNING

The car's driving characteristics change depending on how heavily it is loaded and how the load is distributed.

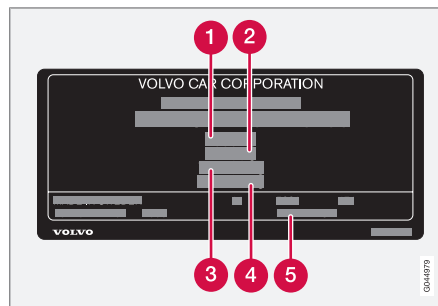

For decal location, see page 284.

- 1 Max. total weight
- 2 Max. train weight (car+trailer)
- 3 Max. front axle load
- 4 Max. rear axle load
- 5 Equipment level

Max. load: See registration document.

Max. roof load: 75 kg.

11 Specifications

Dimensions and weights

Towing capacity and towball load

Engine	Maximum weight, braked trailer (kg)	Maximum towball load (kg)
DRIVE	1300	75
D2	1300	75
2.0F	1350	75
2.0	1350	75
others	1500	75

Engine	Maximum weight, unbraked trailer (kg)	Maximum towball load (kg)
2.0, D2 and DRIVE	650	50
others	700	50

Engine specifications

Overview



NOTE

Not all engines are available in all markets.

Engine	Engine code ^A	Output (kW/rpm)	Output (hp/rpm)	Torque (Nm/rpm)	No. of cylinders	Bore (mm)	Stroke (mm)	Swept volume (litres)	Compression ratio
2.0F	B4204S4	107/6000	145/6000	185/4500	4	87.5	83.1	1.999	10.8:1
2.0	B4204S3	107/6000	145/6000	185/4500	4	87.5	83.1	1.999	10.8:1
T5	B5254T7	169/5000	230/5000	320/1500 – 5000	5	83	93.2	2.521	9.0:1
DRIVE	D4162T	84/3600	115/3600	270/1750-2500	4	75	88.3	1.560	16.0:1
D2	D4162T	84/3600	115/3600	270/1750-2500	4	75	88.3	1.560	16.0:1
D3	D5204T5	110/3500	150/3500	350/1500-2750	5	81	77	1.984	16.5:1
D4	D5204T	130/3500	177/3500	400/1750-2750	5	81	77	1.984	16.5:1

^A Engine code, component and serial number can be read on the engine, see page 284.

Engine oil

Adverse driving conditions

Adverse driving conditions can lead to abnormally high oil temperature or oil consumption. Below are some examples of adverse driving conditions.

Check the oil level more frequently for long journeys:

- towing a caravan or trailer
- in mountainous regions
- at high speeds
- in temperatures colder than $-30\text{ }^{\circ}\text{C}$ or hotter than $+40\text{ }^{\circ}\text{C}$.

The above also apply to shorter driving distances at low temperatures.

Choose a fully synthetic engine oil for adverse driving conditions. It provides extra protection for the engine.

Volvo recommends Castrol oil products.



IMPORTANT

In order to fulfil the requirements for the engine's service intervals all engines are filled with a specially adapted synthetic engine oil at the factory. The choice of oil has been made very carefully with regard to service life, starting characteristics, fuel consumption and environmental impact.

An approved engine oil must be used in order that the recommended service intervals can be applied. Only use a prescribed grade of oil for both filling and oil change, otherwise you will risk affecting service life, starting characteristics, fuel consumption and environmental impact.

Volvo Car Corporation disclaims all warranty liability if engine oil of the prescribed grade and viscosity is not used.

Volvo recommends that oil changes are carried out at an authorised Volvo workshop.

Engine oil

Engine oil grade

Engine	Engine code	Recommended oil grade	Volume, incl. oil filter (litres)
2.0F	B4204S4	Oil grade: ACEA A5/B5 Viscosity: SAE 5W-30	approx. 4.3
2.0	B4204S3		approx. 4.3
DRIVE	D4162T		approx. 3.8
D2	D4162T		approx. 3.8
D4	D5204T	Oil grade: ACEA A5/B5 Viscosity: SAE 0W-30	approx. 5.9
D3	D5204T5		approx. 5.9
T5	B5254T7		approx. 5.8

For filling engine oil, see page 222.

11 Specifications

Fluids and lubricants

Overview

IMPORTANT

The recommended transmission fluid must be used to prevent damage to the gearbox. Do not mix with any other transmission fluid. If the transmission is topped up with a different fluid, contact a workshop nearby for servicing. Volvo recommends that you contact an authorised Volvo workshop.

Gearbox oil

Manual gearbox	Volume (litres)	Prescribed transmission fluid
B6	1.6	BOT 350M3
MTX75	1.8	
M66	1.9	

Automatic gearbox	Volume (litres)	Prescribed transmission fluid
MPS6	7.3	BOT 341
AW55-51	7.7	JWS 3309
TF-80SC	7.0	AW1

Fluids and lubricants

Fluids

Fluid	System	Volume (litres)	Recommended oil grade
Coolant	2.0 and 2.0F	6.5	Coolant recommended by Volvo mixed with 50% water ^A , see the packaging. The thermostat starts opening at: petrol engines 90 °C diesel engines 82 °C diesel engine (D2) 83 °C
	T5, manual gearbox	7.0	
	T5, automatic gearbox	7.5	
	D2 and DRIVe	6.2	
	D3 and D4	8.5	
Refrigerant	Air conditioning	^B	R134a (HFC134a) Oil: PAG
Brake fluid	Brake system	0.6	DOT 4+
Power steering fluid	Power steering	0.8 – 0.9	WSS M2C204-A2 or equivalent product with same specifications.
Washer fluid	4-cyl. Petrol/Diesel	4.0	Washer fluid recommended by Volvo - with frost protection during cold weather and below freezing point.
	5-cyl. Petrol/Diesel	6.5	

Fluids and lubricants

Fluid	System	Volume (litres)	Recommended oil grade
Fuel	Petrol: 2.0, 2.0F	approx. 55	Petrol: see page 143
	Petrol: T5	approx. 62	
	Diesel: D2 and DRIVE	approx. 52	Diesel: see page 144
	Diesel: D3 and D4	approx. 60	

A Water quality must fulfil the standard STD 1285.1.

B Refrigerant quantity varies depending on engine variant. Contact an authorised Volvo workshop for the correct information.

Fuel consumption

There are several causes that can affect fuel consumption negatively. Examples of this are:

- The driver's driving style
- If the customer has specified wheels larger than those fitted as standard on the model's basic version, then resistance increases.
- High speed results in increased wind resistance
- Fuel quality, road and traffic conditions, weather and the condition of the car.

Even a combination of the above-mentioned examples can result in significantly improved consumption.

To bear in mind

Tips that the driver can use in order to reduce consumption:

- Drive gently and avoid unnecessary acceleration as well as braking too hard.
- Drive with the correct air pressure in the tyres and check this regularly - select ECO tyre pressure for best results, see the tyre pressure table on page 296.
- Choice of tyres can affect fuel consumption - seek advice on suitable tyres from a dealer.

See further information and more advice on pages 13 and 140.

See page 142 for general information on fuel.

11 Specifications

Wheel and tyres, dimensions and pressure

Approved tyre pressures

Engine	Tyre size	Speed (km/h)	Load, 1 - 3 persons		Max. load		ECO pressure ^B
			Front (kPa) ^A	Rear (kPa)	Front (kPa)	Rear (kPa)	
D2 DRIVE	195/65 R15	0-160	230	210	270	270	270
		160+	250	210	280	260	-
	205/55 R16	0-160	230	210	250	250	250
		160+	250	210	280	260	-
	205/50 R17	0-160	240	220	250	250	250
		160+	260	220	280	260	-
2.0 2.0F	195/65 R15	0-160	230	210	250	250	250
	205/55 R16	160+	250	210	280	260	-
		0-160	240	220	250	250	250
	215/45 R18	160+	260	220	280	260	-

Wheel and tyres, dimensions and pressure

Engine	Tyre size	Speed (km/h)	Load, 1 - 3 persons		Max. load		ECO pressure ^B
			Front (kPa) ^A	Rear (kPa)	Front (kPa)	Rear (kPa)	
T5 D3	205/55 R16	0-160	230	210	250	250	250
		160+	260	210	280	260	-
D4	205/50 R17	0-160	240	220	250	250	250
	215/45 R18	160+	270	220	290	270	-
Temporary Spare Tyre		0-80	420	420	420	420	-

^A In certain countries there is the "bar" unit beside the SI unit "pascal": 1 bar = 100 kPa.

^B Economical driving, see page 196



NOTE

All engines, tyres or combinations of these are not always available in all markets.

Electrical system

General

The car has a voltage-regulated AC alternator. The electrical system is single-pole and uses the chassis and engine casing as a conductor.

The battery capacity is dependent upon the equipment level in the vehicle. If the starter battery is replaced, therefore, you must ensure that you switch to a battery with the same

capacity as the original battery (see the label on the battery).

Battery

Voltage (V)	Cold start capacity, CCA - Cold Cranking Amperes (A)	Reserve capacity (minutes)	Capacity (Ah)
12	590	100	60
	760 ^A	120	70
12	700 ^B	135	80

^A Cars equipped with High Performance audio system.

^B Cars equipped with diesel, keyless drive, Premium Sound audio system, fuel-driven heater or RTI.

Bulbs

Lighting	Output (W)	Type
Dipped beam, halogen	55	H7 LL
Main beam, halogen	65	H9
Extra main beam, ABL	55	H7 LL
Front direction indicators	24	PY24W SV
Position/parking lamps, front	5	W5W LL BV



Electrical system

Lighting	Output (W)	Type
Side marker lamps, front	5	WY5W LL
Fog lamps	35	H8
Side direction indicators, door mirrors	5	WY5W LL
Front courtesy lighting	3	T10 Socket W2.1x9.5d
Glovebox lighting	3	T10 Socket W2.1x9.5d
Vanity mirror lighting*	2	T5 Socket W2x4.6d
Cargo area lighting	5	Socket SV8.5 Length 38 mm
Number plate lighting	5	C5W LL
Rear direction indicators	21	PY21W LL
Position lamps, rear	4	P21/4W LL
Brake light	21	P21W LL
Reversing lamp	21	P21W LL
Rear fog lamp	21	P21/4W LL

Type approval

Remote control key system

Lock system standard

Country	
EU	 <p>Continental SWK49269 FCC ID: KR55WK49269 IC: 2877-SWK49269 CMI ID: 2016B31174 TRO/PSI: 2006/24 TA: 2006/666 C04607LPR210T0 Made in Cz G046203</p>
Korea	 <p>Continental S1E-SWK49271 Made in Cz G046205</p>
Singapore, China	 <p>Continental SWK49568 Approved by IDA for use in Singapore DB01752 Made in Cz G046206</p>

Keyless locking system (Keyless drive)

Country	
EU	 <p>Continental SWK49561 FCC ID: KR55WK49560 IC: 2877-SWK49561 CMI ID: 2016B31173 TRO/PSI: 2006/24 TA: 2006/666 C04607LPR210T0 Made in Cz G046207</p>
Korea	 <p>Continental S1E-SWK49257 Made in Cz G046210</p>
Hong Kong	 <p>Continental SWK49258 G046208</p>
Singapore, China	 <p>Continental SWK49569 Approved by IDA for use in Singapore DB01752 Made in Cz G046211</p>

Symbols in the display

General





There are a variety of different symbols in the display in the car. The symbols are divided into warning, indicator and information symbols. Shown below are the most common symbols with their meanings and a reference to where in the manual further information can be found. For more information on symbols and text messages, see pages 48 and 52.







 - Red warning symbol, illuminates when a fault has been indicated which could affect the safety and/or driveability of the car. An explanatory text is shown on the information display at the same time.

 - Yellow information symbol, illuminates in combination with text in the information display, when a deviation in any of the car's systems has occurred. The yellow symbol information can also illuminate in combination with other symbols.





Symbols in the display



Indicator and warning symbols in the combined instrument panel

Symbol	Meaning	Page
	Warning	19, 30, 48, 51, 159
	Information	48, 51, 159, 168, 170
	Emissions system	48, 49
	Fault in the ABS system	49, 50
	Rear fog lamp	49



Symbol	Meaning	Page
	Stability system, DSTC*	49, 167, 168
	Engine pre-heater (diesel)	49
	Low level in fuel tank	49
	Indicator symbol for trailer	50
	Parking brake applied	50
	Airbags - SRS	19, 50

Symbols in the display

Symbol	Meaning	Page
	Low oil pressure	48, 50
	Seatbelt reminder	16, 50
	Alternator not charging	50
	Fault in brake system	50, 165
	Main beam indicator	47

Symbol	Meaning	Page
	Left direction indicators	47
	Right direction indicators	47

Other information symbols in the combined instrument panel



Symbol	Meaning	Page
	Rain sensor*	65
	Cruise control*	67
	Gear shift indicator*	155

Information symbols in the centre console display

Symbol	Meaning	Page
	Surround sound (only Premium Sound)	255
	News	259
	Programme types	259
	Regional radio programmes	260
	Audio files	262
	Directory in CD disc	262
	Traffic information	259
	Phone*	276
	Bluetooth™ hands-free*	276

Symbols in the display

Information symbols in the roof console display

Symbol	Meaning	Page
	Seatbelt reminder	17
	Airbag, passenger seat, activated	22, 23
	Airbag, passenger seat, deactivated	23

A**A/C**

- electronic climate control..... 95
- manual climate control..... 90, 91

ABS fault..... 49, 166

Active Bending Lights (ABL)..... 58

Active headlamps..... 58

Adaptation..... 153

Additional heater (Diesel)..... 100

Adjusting headlamp pattern..... 188

- halogen headlamp..... 188

AF – automatic frequency update..... 260

Airbag..... 20

- activating/deactivating, PACOS..... 22
- driver's and front passenger side..... 21
- key switch off..... 22

AIRBAG 20

Airbag system..... 20

Air conditioning..... 90

- ECC..... 93
- general..... 88

Air conditioning system

- repair..... 221

Air distribution..... 96

- ECC..... 94

Air distribution, A/C..... 91

Air quality system, ECC..... 94

Air vents..... 88

Alarm..... 135

- alarm indicator..... 135
- alarm signals..... 136
- arming..... 135
- automatic alarm activation..... 136
- deactivating a triggered alarm..... 136
- disarming..... 135
- RDS traffic warning..... 259
- reduced alarm level..... 136
- testing the alarm system..... 136

Alcolock..... 146

Antenna location, Keyless drive..... 130

Approach light, duration..... 76, 124

- setting..... 81

Armrest in the rear seat 117

Audio, see also Sound..... 252

Audio volume

- phone..... 270, 278
- phone/media player..... 278
- programme types..... 261
- ring signal, phone..... 278

Auto

- climate control settings..... 93

AUTO

- storing stations..... 257

Auto climate..... 93

Automatic car washes..... 208

Automatic gearbox

- manual gear positions (Geartronic)..... 156
- towing and recovery..... 174
- trailer..... 179, 180

Automatic locking..... 133

Automatic relocking..... 132

Autostart..... 150

Auto volume control..... 255

Auxiliary heater..... 100

Average fuel consumption..... 62

B

Backrest rear seat, lowering..... 116

Bass speaker..... 254

Battery..... 230, 298

- changing the battery in the remote control key..... 131

- maintenance..... 219, 230
 overload..... 141
 specifications..... 298
 start assistance..... 178
 symbols on the battery..... 230
 warning symbols..... 230
- Bioethanol E85..... 143
 Blind spot (BLIS)..... 171
 BLIS..... 77, 171
- Bluetooth
 handsfree..... 276
 mute microphone..... 277
 transfer call to mobile..... 277
- Bluetooth®
 media..... 254
 streaming audio..... 254
- Boarding
 rear seat..... 105
- Bonnet, opening..... 220
- Brake and clutch fluid..... 226
- Brake light..... 60
- Brakes
 anti-lock braking system, ABS..... 166
 brake light..... 60
 Emergency Brake Assistance, EBA ... 166
- emergency brake lights..... 166
 handbrake..... 71
- Brake system..... 165
- Bulb holder
 removal..... 237
- Bulbs
 changing..... 234
- Bulbs, see Lighting..... 234, 298
- [**
-
- Calls
 functions during a call..... 269, 272
 incoming..... 277
 operation..... 269, 277
 volume in phone..... 270
- Car care..... 208
- Car care, leather upholstery..... 210
- Cargo area..... 118
 cargo cover..... 118
 lighting..... 109
 loading..... 187
 safety net..... 120
- Cargo cover..... 118
- Car settings..... 81
- Car upholstery..... 209
- Car wash..... 208
- Catalytic converter..... 143
 recovery..... 174
- CD discs
 storage compartment..... 114
- CD functions..... 262
- Checking the engine oil level..... 222
- Checks
 fluids and oils..... 222
- Children..... 31
 child seats and side airbags..... 24
 location in the car..... 31
 location in the car, table..... 32
 safety..... 31
- Child seat..... 31
- Child seats..... 31
 ISOFIX fixture system for child seats... 36
 size classes for child seats with the ISO-FIX fixture system..... 36
 upper mounting points for child seats.. 39
- Cigarette lighter socket
 front seat..... 54

- Cleaning
- car wash..... 208
 - rims..... 208
 - seatbelts..... 211
 - upholstery..... 209
- Climate control
- general..... 88
 - personal preferences..... 80
- Climate control settings
- auto..... 93
- Clock, adjustment..... 80
- Clutch fluid, checking & topping up..... 226
- Coat hanger..... 113
- Cold start..... 158
- automatic gearbox..... 158
- Collision
- crash mode..... 30
 - inflatable curtain, IC..... 26
- Colour code, paint..... 212
- Combined instrument panel..... 47
- Compass..... 74
- calibration..... 74
 - setting the zone..... 74
- Condensation in headlamps..... 208
- Coolant..... 225
- checking and topping up..... 225
- Cooling system..... 140
- Crash, see Collision..... 30
- Cruise control..... 67
-
- D**
-
- Deadlock
- deactivation..... 133
 - temporary deactivation..... 133
- Deadlocks..... 133
- Defroster..... 91
- Diesel..... 144
- Diesel: engine preheater..... 49
- Diesel particle filter..... 144
- Dipstick, electronic..... 224
- Direction indicators..... 61
- Disc text..... 263
- Disengaging the gear selector inhibitor... 158
- Display, messages..... 52
- Display lighting..... 57
- Dolby Surround Pro Logic II..... 251, 255
- Door mirrors..... 76
- Driver's door control panel..... 46, 72
- Driving
- cooling system..... 140
 - economical..... 140
 - in water..... 140
 - slippery driving conditions..... 141
 - with trailer..... 179
- Driving in water..... 140
- Driving with a trailer
- towball load..... 287
 - towing capacity..... 287
- DSTC, see also Stability control system.. 167
- DSTC, see also Stability system
- symbol..... 49
- During a call, functions..... 272
-
- E**
-
- ECC, electronic climate control..... 89
- Economical driving..... 140
- ECO pressure..... 196
- table..... 196, 296
- Eco Start/Stop DRIVE..... 161

Electrical socket		Environmental labelling, FSC, owner's manual.....	13	Fluids and oils general.....	222
centre console.....	54	EON - Enhanced Other Networks.....	261	Fog lamps	
rear seat.....	54	Equalizer.....	255	rear.....	57
Electrical system.....	298	Error messages in BLIS.....	172	Fog lamps, on/off.....	57
Emergency calls.....	267	Expectant mothers, seatbelt.....	17	Fold down the rear seat backrest	116
Emergency equipment		External dimensions.....	286	Frequency update, automatic.....	260
warning triangle.....	197	Extra mats.....	108	Front seats, heated.....	91
Emergency puncture repair.....	201	F		FSC, environmental labelling.....	13
Emission control				Fuel	
fault indicator.....	49	Fan		CO ₂ emissions.....	295
Engine block heater.....	152	A/C.....	90	consumption.....	295
fuel-driven.....	97	ECC.....	93	fuel consumption, display.....	62
Engine compartment.....	220	Fast-wind.....	263	fuel economy.....	196
coolant.....	225	First aid equipment.....	198	fuel filter.....	144
oil.....	222	Flexifuel.....	152	level indicator.....	49
power steering fluid.....	227	adaptation.....	153	parking heater.....	97
Engine oil.....	222, 290	Floor hatch.....	119	refuelling.....	142
adverse driving conditions.....	290	Floor mats.....	108	Fuses.....	240
capacities.....	290	Fluids, capacities.....	292	box in the engine compartment.....	241
filter.....	222	Fluids and oils.....	222, 292	changing.....	240
oil grade.....	290	Fluids and oils, checks, engine compart- ment.....	222	general.....	240
oil pressure.....	50			relay/fuse box in the passenger com- partment.....	245
Engine specifications.....	289				
Entry, keyless.....	81				

G

Gearbox	
manual.....	155
Gear selector inhibitor.....	157
Geartronic.....	156
General information on fuel.....	142
Glovebox.....	113
locking.....	126
Gross vehicle weight.....	287
GSI - Gear selector assistance.....	155, 162

H

Handbrake.....	71
Hazard warning flashers.....	70
Headlamp pattern adjustment	
Active Bending Lights (ABL)	188
Headlamps.....	56
Head restraint.....	116
Heating	
front seats.....	91, 95
rearview and door mirrors.....	91, 95
rear window.....	91, 95

High-pressure headlamp washing.....	64
HomeLink®	83
Home safe lighting.....	61, 76
setting.....	81

I

IDIS – Intelligent Driver Information System.....	267
Ignition keys.....	151
IMEI number.....	272
Immobiliser.....	124, 151
Inflatable Curtain.....	26
Information display.....	52
Information on fuel.....	142
Infotainment system	
menus.....	250
Inlaid mats.....	108
Instrument lighting.....	57
Instrument overview	
left-hand drive.....	42
right-hand drive.....	44
Interior lighting, see Lighting.....	109

Interior rearview mirror.....	74
automatic dimming.....	74
Intermittent wiping.....	64
iPod®, connection.....	252
ISOFIX fixture system for child seats.....	36

J

Jack.....	197
-----------	-----

K

Kerb weight.....	287
Key	
keyless lock and ignition system.....	128
remote control key.....	124
Key blade.....	125, 129
active locks.....	127
Keyless drive.....	128, 154
starting the car.....	154
Keyless entry.....	81
Keyless start (keyless drive).....	128
Keypad in the steering wheel.....	67, 69, 268

- Key positions..... 150
- Kick-down
 automatic gearbox..... 157
- L**
-
- Lambda-sond..... 143
- Leather upholstery, washing instructions 210
- Lighting
 Active Xenon headlamps..... 58
 approach light, duration..... 76, 124
 automatic lighting..... 110
 automatic lighting, dipped beam..... 56
 bulbs, specifications..... 298
 cargo area..... 109
 dipped beam..... 56
 display lighting..... 57
 front fog lamps..... 57
 headlamp levelling..... 56
 home safe lighting..... 61, 76
 in passenger compartment..... 109
 lighting panel, passenger compartment 56
 main/dipped beam..... 56, 61
 position/parking lamps..... 56
 reading lamps..... 109
 rear fog lamp..... 57
- Lighting, bulb replacement..... 234
 bulb holder, rear..... 238
 cargo area..... 238
 dipped beam..... 235
 direction indicators..... 236
 fog lamp..... 237
 front..... 234
 main beam..... 235
 number plate lighting..... 238
 parking lamps..... 236
 passenger compartment lighting in
 cargo area..... 239
 position lamps..... 236
 side marker lamps..... 236
 vanity mirror..... 239
- Loading
 general..... 187
 load capacity..... 187
 load retaining eyelets..... 120
- Load retaining eyelets..... 120
- Locking..... 129
 unlocking..... 132
- Locking/unlocking..... 132
 inside..... 132
 outside..... 132
- Locks
 locking..... 132
- Lubricants..... 292
- Lubricants, capacities..... 292
- M**
-
- Main/dipped beam, see Lightning..... 56
- Main beam
 flashing..... 61
- Main beam "flash"..... 61
- Maintenance..... 219
 rustproofing..... 214
 self-maintenance..... 219
- Making calls..... 269, 277
- Manual gearbox..... 155
 GSI - Gear selector assistance... 155, 162
 towing and recovery..... 174
- Manual gear positions (Geartronic)..... 156
- Max. roof load 287
- Memory function in seats..... 105
- Menus
 audio system..... 250
- Menu structure..... 80
 media player..... 265

phone, menu options.....	274
phone, overview.....	273
Messages in BLIS.....	172
Messages in the information display.....	52
Meters in the combined instrument panel	
fuel gauge.....	47
outside temperature gauge.....	47
speedometer.....	47
tachometer.....	47
trip meter.....	47
Misting	
attending to the windows.....	88
condensation in headlamps.....	208
rear window.....	91
removing with defroster function....	91, 94
timer function.....	91, 94
Mobile phone	
connect.....	278
handsfree.....	276
register phone.....	276
Mounting points (child seat).....	39

N

News.....	259
-----------	-----

O

Oil, see also Engine oil.....	222, 290
Oil level low.....	222
One-key dial.....	271
Owner's manual, environmental labelling..	13
Oxyhydrogen gas.....	178

P

PACOS.....	22
PACOS, switch.....	22
Paintwork	
colour code.....	212
damage and touch-up.....	212
Parking assistance.....	169
parking assistance sensors.....	170
Parking brake.....	50, 71
Parking heater	
battery and fuel.....	97
general.....	97
parking on a hill.....	97
symbols and display messages.....	98
time setting.....	99
Passenger compartment filter.....	88

Passenger compartment heater	
fuel-driven.....	97
Personal preferences.....	80
approach light, duration.....	81
auto blower adjust.....	80
automatic locking.....	81
doors unlock.....	81
home safe lighting.....	81
keyless entry.....	81
lock confirm. light.....	81
recirculation timer.....	80
unlock confirm. light.....	81
Petrol grade.....	143
Phone	
calling from the phone book.....	271
connect.....	278
controls.....	268
entering text.....	270
handsfree.....	276
incoming calls.....	277
making calls.....	277
on/off.....	269
one-key dial.....	271
phone book.....	279
phone book, shortcut.....	279
receiving a call.....	277
register phone.....	276

- standby, standby mode..... 269
 traffic safety..... 268
- Phone book
 handling numbers..... 270
- Phone system..... 267
- Pinch protection, sunroof..... 79
- Polishing..... 209
- Power seat..... 104
- Powershift gearbox..... 158, 174
- Power steering fluid, checking and topping up..... 227
- Power sunroof..... 78
- Power windows..... 72
 passenger seat..... 73
- Programme type..... 260
- PTY – Programme type..... 260
- Puncture, see Tyres..... 197, 199
- Putting calls on hold..... 269
- R**
-
- Radio
 EON..... 261
 frequency update..... 260
- news..... 259
 programme types..... 258
 radio settings..... 257
 radio stations..... 257
 REG..... 260
- Radio text..... 260
- Rain sensor..... 65
- Random, CD and audio files..... 263
- RDS functions..... 258
 resetting..... 261
- Reading lamps, see Lighting..... 109
- Rear seat..... 116
 boarding..... 105
- Rearview and door mirrors
 automatic retracting/extending..... 76, 81
 compass..... 74
 door..... 76
 electrically retractable..... 76
 interior..... 74
- Recirculation
 A/C..... 90
 ECC..... 94
- Recommended child seats 31
- Reduced guard
 settings..... 81
- Refrigerant..... 221
- Refuelling
 fuel cap..... 142
 fuel filler flap, electrical opening..... 142
 refuelling..... 142
- Refusing a call..... 269
- REG - Regional radio programmes..... 260
- Relay/fuse box: see Fuses..... 240
- Remote control..... 124
 replacing the battery..... 131
- Remote control, HomeLink®
 programmable 83
- Remote control key..... 151
 battery replacement..... 131
 detachable key blade..... 125
 functions..... 124
- Remote control key system, type approval..... 300
- Resetting the door mirrors..... 76
- Reverse gear inhibitor..... 155
- Rims
 cleaning..... 208
- Roof load, max. weight 287
- Rustproofing..... 214

S

Safety

safety systems, table..... 29

Safety net..... 120

Scan

CD and audio files..... 263

radio stations..... 258

Seatbelt

pregnancy..... 17

seatbelt guide..... 18

seatbelt tensioner..... 18

Seatbelt reminder..... 17

Seatbelts..... 16

Seats

head restraints, rear..... 116

lowering the rear backrest..... 116

manual setting..... 104

power seat..... 104

Securing loads 120

Service programme..... 218

Side airbags..... 24

Side airbag SIPS..... 24

SIM card..... 267

SIPS bags..... 24

SMS..... 272

read..... 272

write..... 272

Soot filter..... 52, 145

Soot filter full..... 145

Sound

audio settings..... 252, 254

audio source..... 252

volume..... 252

Spare wheel..... 197

temporary spare..... 195, 197

Spin control..... 167

SRS system

general..... 20

Stability and traction control system..... 167

Stains..... 209

Standby, phone..... 269

Start assistance..... 178

Starting the engine..... 150

keyless drive..... 128, 154

Steering lock..... 150

Steering wheel

cruise control..... 67

keypad..... 67, 69, 268

steering wheel adjustment..... 70

Stone chips and scratches..... 212

Storage compartment..... 112

CD discs..... 114

Storage spaces in the passenger compartment..... 112

Storing stations, manual and automatic.. 257

Streaming audio..... 254

Subwoofer..... 254

Sunroof..... 78

opening and closing..... 78, 79

pinch protection..... 79

sunscreen..... 79

ventilation position..... 78

Sunscreen, sunroof..... 79

Surround..... 251, 255

Symbols..... 168

indicator symbols..... 49, 50

warning symbols..... 48

Symbols and display messages

parking heater..... 98

T**Tailgate**

- driving with open tailgate..... 141
- locking/unlocking..... 124, 132

Tank volume..... 292

Technical data, engine..... 289

Temperature

- actual temperature..... 89
- passenger compartment, electronic climate control..... 95
- passenger compartment, manual climate control..... 92

Testing the alarm system..... 136

Timer

- A/C..... 91
- ECC..... 94

Tools..... 197

Total airing function..... 133

Towbar, see Towing equipment..... 181

Towing..... 174

- towing eye..... 176

Towing capacity..... 287

Towing equipment..... 181

- installation..... 183

removing..... 185

specifications..... 182

Towing eye..... 176

TP – Traffic information..... 259

Traffic information..... 259

Trailer..... 179

- cable..... 181

Trip computer..... 62

Tuning Radio..... 257

Type approval, remote control key system..... 300

Type designation..... 284

Tyres

direction of rotation..... 195

driving characteristics..... 192

general..... 192

maintenance..... 192

pressure..... 196, 296

puncture repair..... 201

specifications..... 192

speed ratings..... 192

tread wear indicators..... 193

winter tyres..... 195

U

Unlocking..... 129, 132

- settings..... 81

Upper mounting points, child seat..... 39

USB, connection..... 252

V

Ventilation..... 88

Vibration damper..... 181

Volume

audio system..... 252

auto volume control..... 255

media player..... 252

W**Warning lamp**

- stability and traction control system. . 167

Warning symbol, airbag system..... 19

Warning triangle..... 197

Washer fluid, filling..... 225

Washers		
headlamps.....	64	
rear window.....	65	
washer fluid, filling.....	225	
windscreen.....	64	
Waxing.....	209	
Weights		
kerb weight.....	287	
Wheels		
changing.....	199	
installation.....	200	
removal.....	199	
rims.....	194	
snow chains.....	194	
spare wheel.....	197	
Whiplash injury.....	27	
WHIPS		
child seat/booster cushion.....	27	
whiplash injury.....	27	
Windscreen wipers.....	64	
rain sensor.....	65	
Winter tyres.....	195	
Wiper		
rear window.....	65	
Wiper blades.....	228	
cleaning.....	228	
		replacing, rear window..... 228
		replacing, windscreen..... 228

