

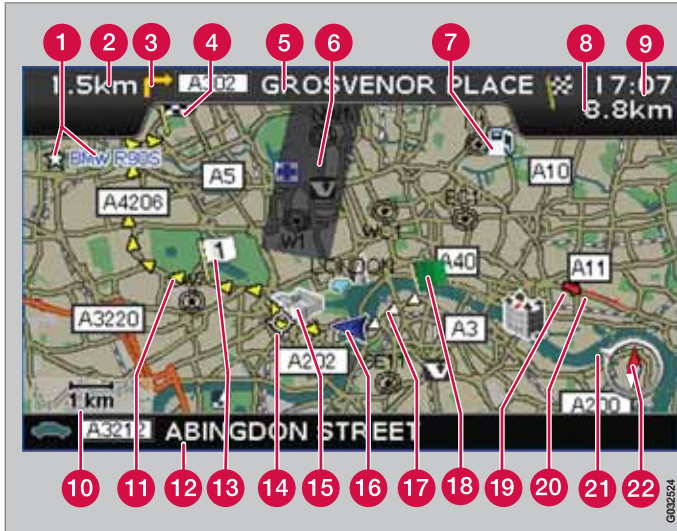

C30, C70 & XC90

ROAD AND TRAFFIC INFORMATION SYSTEM - RTI WEB EDITION





- 3 Event at next guidance point
- 4 Itinerary destination
- 5 Name of next road/street
- 6 Excluded area for route
- 7 Facility (petrol station)
- 8 Estimated distance to destination
- 9 Estimated travel time to destination or estimated time of arrival (ETA)
- 10 Map scale
- 11 Planned route
- 12 Current road/street name
- 13 Planned route interim destinations
- 14 Next guidance point
- 15 Known landmark
- 16 Position of car
- 17 Completed planned route
- 18 Planned route start
- 19 Traffic information
- 20 Section covered by traffic information
- 21 Arrow on outer compass ring indicates direction to destination
- 22 Compass

Road type	Colour
Motorway	Green
Primary road	Red
Smaller primary road	Dark grey
Ordinary road	Light grey

Text and symbols on screen

- 1 Stored location (any symbol and text)
- 2 Distance to next guidance point



ROAD AND TRAFFIC INFORMATION - RTI

Volvo's navigation system is a traffic information and road navigation system developed by Volvo. The system guides you to a destination and gives information along the route. It informs of situations that can affect the drive, such as accidents, road works and shows alternative routes.

It is possible to create an itinerary, search for facilities along the route, store special places etc. The system displays the car's exact position and in event of a wrong turning always corrects to guide you to the destination.

You will see just how intuitive it is to use. Try it out. In order to get along with the system we recommend that you familiarise yourself with the information in this manual.

By facilitating accessibility and shortening driving distances, Volvo's navigation system contributes to a better environment.

License agreement NAVTEQ DATABASE

For information for the end user - see page 78.



01 Get to know your navigation system

Manual.....	8
Before starting.....	9
Menus.....	11
Component location and functions C30... 14	
Component location and functions C70... 16	
Component location and functions XC90. 18	
Controls.....	20
Keyboard.....	21
Display modes and voice messages..... 22	
Main unit, updating, maintenance..... 24	



02 Easy user mode

Menus.....	28
Menu tree.....	30
Set destination.....	31
Show/Delete destination.....	34
Settings.....	35



03 Advanced user mode

Menus.....	38
Menu tree.....	42
Set destination.....	44
Itinerary.....	49
Current position.....	52
Traffic information.....	53
Settings.....	54
Simulation.....	59



04 Traffic information

General.....	62
Avoiding traffic problems.....	63
Selecting information.....	65
Reading information.....	66
Transmitters.....	67

04



05 Symbols on the map

Landmarks and road numbers.....	70
Symbols for facilities.....	71

05



06 Questions and answers

Frequently asked questions.....	76
EULA - License agreement.....	78
Copyright.....	80

06



07 Alphabetical Index

Alphabetical Index..... 82

07



Manual.....	8
Before starting.....	9
Menus.....	11
Component location and functions C30.....	14
Component location and functions C70.....	16
Component location and functions XC90.....	18
Controls.....	20
Keyboard.....	21
Display modes and voice messages.....	22
Main unit, updating, maintenance.....	24

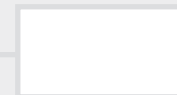
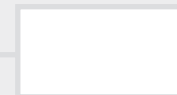

01

GET TO KNOW YOUR NAVIGATION SYSTEM





01 Get to know your navigation system

01

Manual

General information on the manual

The manual describes general functions for all markets, but market specific information may also be included.

Like the system, the manual is divided into **Easy** and **Advanced** user settings.

Menu options/Search paths

All options that can be selected on the display are marked in the manual with slightly larger and grey-shaded text, e.g. **Set destination**.

Search paths in the menu tree are stated as, e.g.:

Set destination → Address → City

Special text

NOTE

Texts marked with NOTE provide advice or tips to facilitate use of e.g. features and functions.

Footnote

There is information in the manual that is added as a footnote at the bottom of the page or in direct association with a table. This information is a supplement to the text to which it refers via the footnote number.

Changes in the manual

The specifications, design features and illustrations in this owner's manual are not binding.

We reserve the right to make modifications without prior notice.

© Volvo Car Corporation

General

The navigation system can be used without a destination being selected. The map with the position of the car is shown on the screen and the car is shown with a blue triangle.

The system is updated continuously and could therefore contain functions not described in this manual.

The system content may vary slightly from country to country and some menu options are not available to all countries for technical reasons.

Startup



The system starts by displaying a screen where you have to confirm the text content by pressing **ENTER** after selecting **Easy (Easy mode)** or **Advanced (Advanced mode)**.

Map position

After Startup, the Main menu is displayed briefly until the screen switches to Map mode. At this point, the current map covers the entire screen.

- Press **BACK** to activate the Main menu, see page 28.
 - Press **ENTER** to activate the Quick menu, see page 28.
1. Press the **navigation button** to activate Scroll mode, in order to view parts of the map that are outside of the screen for example.
 2. In this mode **ENTER** activates the Scroll menu, see page 28.

Settings

The system is supplied with default settings, but starts with the settings last made.

If a setting has been changed and the factory setting is required again then only the current function is affected.

There is no function that resets all settings simultaneously.

On/Off

On

The system is switched on automatically when the ignition key/starter knob¹ is turned to position **I** or **II**.

If the system has been switched off manually, it must also be switched on manually as follows:

1. The ignition key/starter knob must be in position **I** or **II** (see the instruction manual for the car).
2. Press **ENTER** or **BACK**.
3. The screen is activated.

The system may need a few seconds in order to detect the position and movement of the car.

Off

The system is switched off automatically when the ignition key is turned to position **0**.

The system can be switched off manually so that it does not start automatically the next time the ignition key is turned to position **I**, as follows:

1. Press **BACK** to reach the Main menu.

¹ Used instead of an ignition key in cars fitted with the Keyless system.



01 Get to know your navigation system

01

Before starting

2. Scroll to **Shut down** with the **navigation button**.
3. Press **ENTER**.
4. The screen is powered down.

NOTE

The system is also available with the engine switched off. For this reason, remember that frequent use of the navigation system with the engine switched off can drain the battery.

Simple/Advanced setting

When the navigation system starts up the required user settings are selected.

- **Easy**

Only the most important menus are available in this mode. Suitable for simply travelling from point A to B.

- **Advanced**

All settings and functions are available in this mode.

Switching between settings

It is possible to switch between **Easy** and **Advanced** settings under **Settings**.

Settings made in **Easy** mode do not transfer over to **Advanced** mode and vice versa, but instead are stored in each respective mode.

Refer to the following page to see which menus differ between the two options.

Demo (simulated guidance)

Specify a destination in order to obtain an overview of how guidance works. Guidance to the specified destination can be simulated when the car is stationary.

This function is available only in mode **Advanced**.

For more information on Demo, see page 59.

Menu options in two levels Simple mode

Set destination	
→	Address
→	Facilities
→	Last 20
→	Point on map
Show destination	
Delete destination	
Settings	

- Guiding voice
- Guiding volume
- Language
- Colour
- Map view
- User mode

Shut down

For information on all possible menu options in Simple mode, see page 30.

Menu options in two levels Advanced mode

Set destination	
→	Address
→	Facilities
→	Stored locations
→	Last 20
→	Return trip
→	Point on map
→	Latitude/longitude
Itinerary	
→	Start guidance
→	Add to itinerary
→	Route options
→	Clear itinerary
Next destination	



01 Get to know your navigation system

01

Menus

→ **Address**

Current position

Settings

→ **Traffic information**

→ **Route options**

→ **Map options**

→ **Guiding options**

→ **System options**

→ **Start demo**

Shut down

For information on all possible menu options in Advanced mode, see page 42.



Menu

01



01 Get to know your navigation system

01

Component location and functions C30

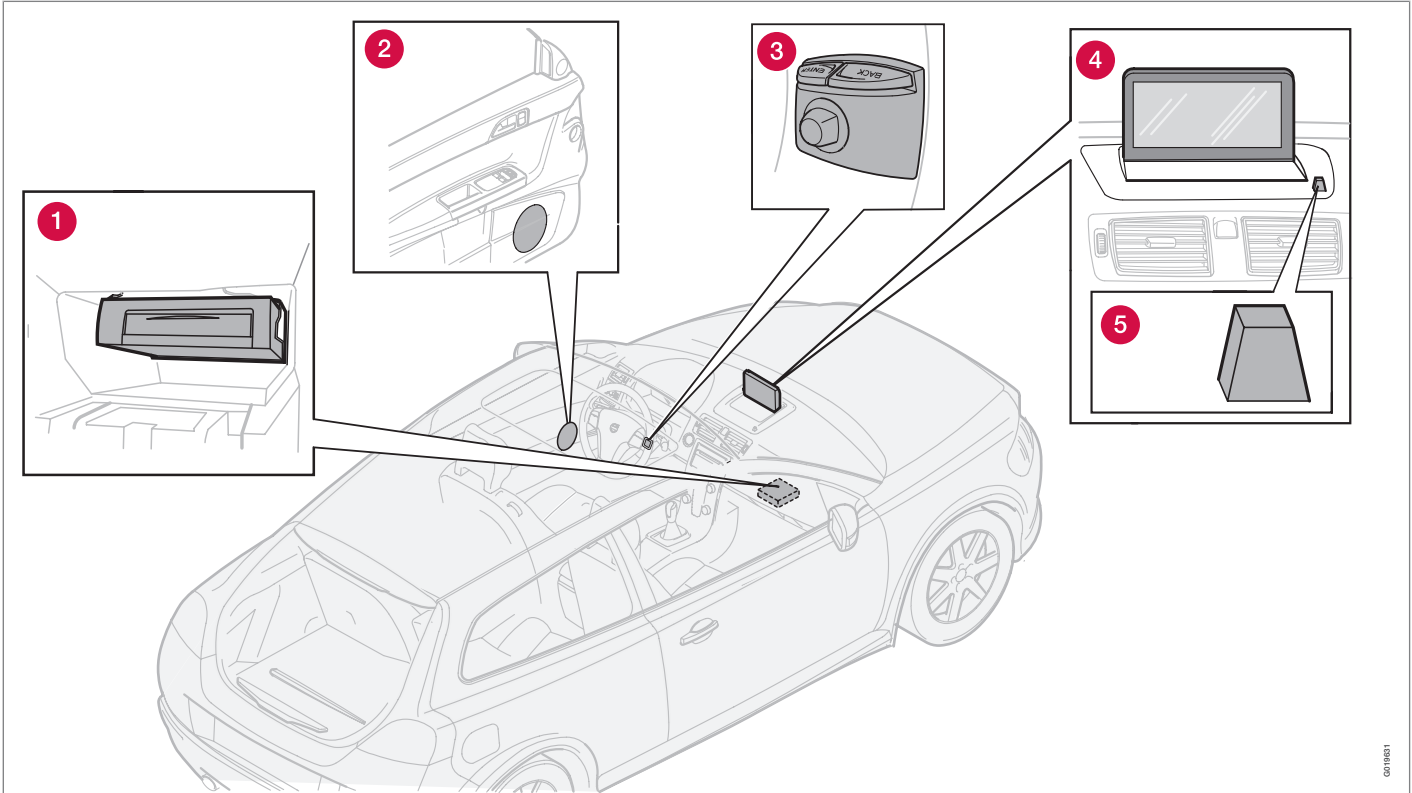

06/19/21

Component location and functions C30

1 Main unit

The system is hard disk based. For more information, see page 24.

The main unit is fitted in the glovebox and includes the following functions:

- Calculating the position of the car
- Calculating the route to the specified destination
- Handling traffic information
- Voice guidance
- Storing map data
- DVD player; for updating the map data and software.

NOTE

The main unit's DVD player is designed for Volvo's map discs.

The GPS and TMC receivers are integrated in the main unit.

Positioning

The car's speed sensor and a gyro calculate the current position and the direction of travel of the car using signals from the GPS satellite system.

The advantage of this concept is that the navigation system registers and calculates the

route outline even if the GPS signal is temporarily lost, e.g. when driving through a tunnel.

Traffic information

TMC (Traffic Message Channel) is a standardised coding system for traffic information. The receiver automatically searches for the correct frequency. Reception takes place via the FM antenna.

The coverage area of the system is under constant development which is why updates can sometimes be necessary, see page 24.

Irrespective of whether **Easy** or **Advanced** user settings are selected, traffic information transmitted is always received and presented. For more information, see page 62.

2 Speakers

Navigation system audio uses the front loudspeakers.

3 Keypad

The keypad is located on the right-hand rear side of the steering wheel. Use it to scroll between different menu options, to confirm selections or to move back in menus. For more information, see page 20.

4 Screen

The screen displays maps and provides detailed information on route type, distance, menus etc. For screen care, see page 24

5 IR receiver

The IR receiver for the remote control is located adjacent to the screen on the speaker grille. For more information, see page 20.



01 Get to know your navigation system

01

Component location and functions C70

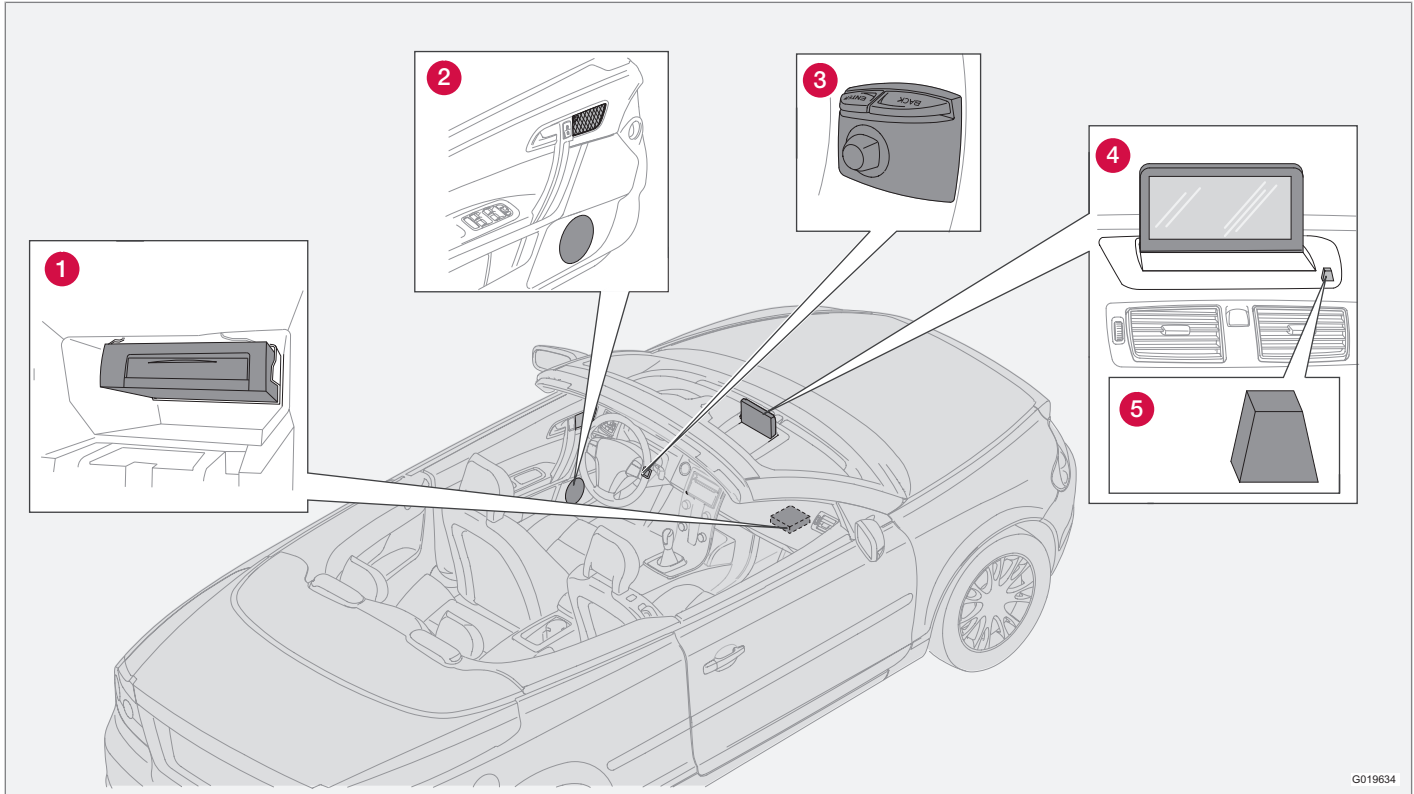

G019634



Component location and functions C70

1 Main unit

The system is hard disk based. For more information, see page 24.

The main unit is fitted in the glovebox and includes the following functions:

- Calculating the position of the car
- Calculating the route to the specified destination
- Handling traffic information
- Voice guidance
- Storing map data
- DVD player; for updating the map data and software.

NOTE

The main unit's DVD player is designed for Volvo's map discs.

The GPS and TMC receivers are integrated in the main unit.

Positioning

The car's speed sensor and a gyro calculate the current position and the direction of travel of the car using signals from the GPS satellite system.

The advantage of this concept is that the navigation system registers and calculates the

route outline even if the GPS signal is temporarily lost, e.g. when driving through a tunnel.

Traffic information

TMC (Traffic Message Channel) is a standardised coding system for traffic information. The receiver automatically searches for the correct frequency. Reception takes place via the FM antenna.

The coverage area of the system is under constant development which is why updates can sometimes be necessary, see page 24.

Irrespective of whether **Easy** or **Advanced** user settings are selected, traffic information transmitted is always received and presented. For more information, see page 62.

2 Speakers

Navigation system audio uses the front loudspeakers.

3 Keypad

The keypad is located on the right-hand rear side of the steering wheel. Use it to scroll between different menu options, to confirm selections or to move back in menus. For more information, see page 20.

4 Screen

The screen displays maps and provides detailed information on route type, distance, menus etc. For screen care, see page 24

5 IR receiver

The IR receiver for the remote control is located adjacent to the screen on the speaker grille. For more information, see page 20.



01 Get to know your navigation system

01

Component location and functions XC90

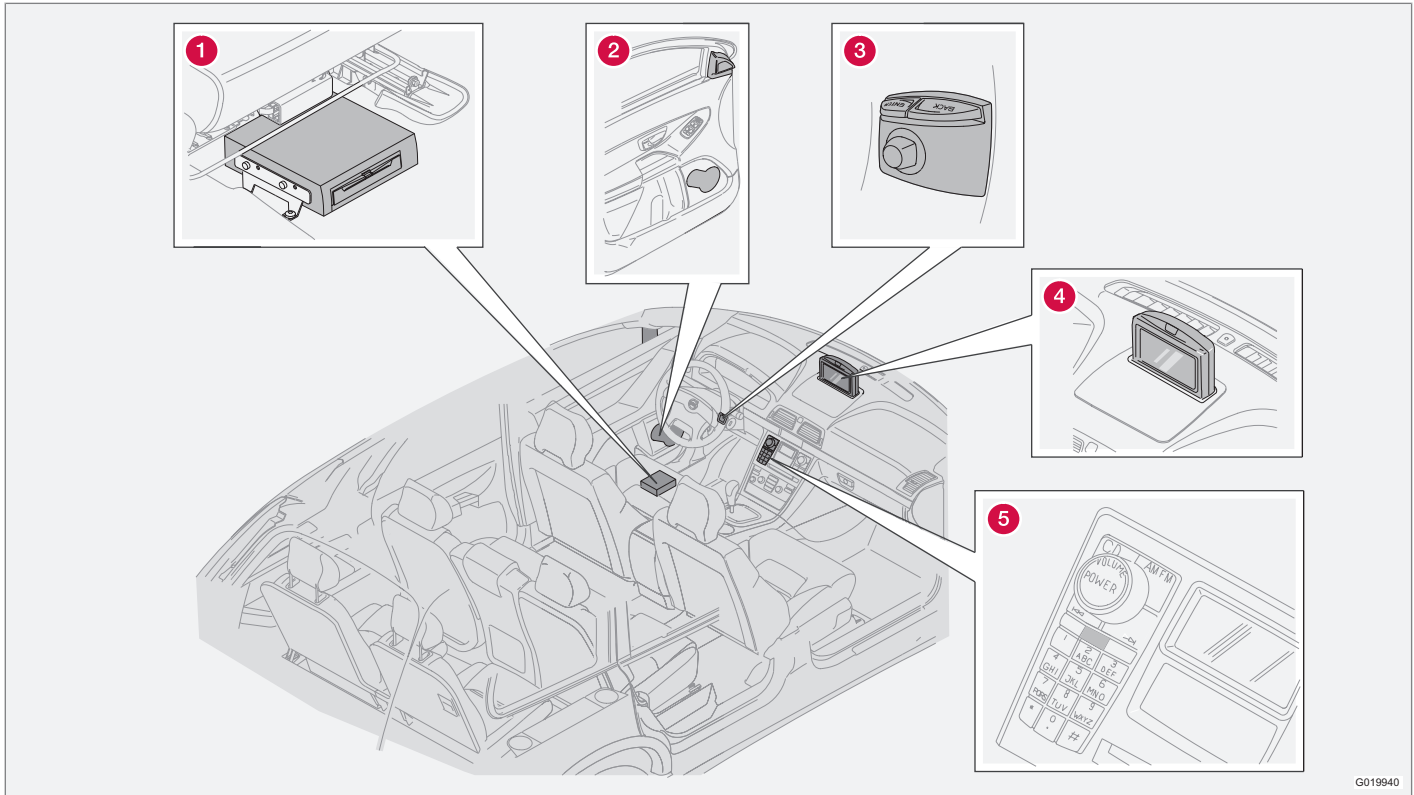

G019940

Component location and functions XC90

1 Main unit

The system is hard disk based. For more information, see page 24.

The main unit is fitted under the driver's seat and includes the following functions:

- Calculating the position of the car
- Calculating the route to the specified destination
- Handling traffic information
- Voice guidance
- Storing map data
- DVD player; for updating the map data and software.

NOTE

The main unit's DVD player is designed for Volvo's map discs.

The GPS and TMC receivers are integrated in the main unit.

Positioning

The car's speed sensor and a gyro calculate the current position and the direction of travel of the car using signals from the GPS satellite system.

The advantage of this concept is that the navigation system registers and calculates the

route outline even if the GPS signal is temporarily lost, e.g. when driving through a tunnel.

Traffic information

TMC (Traffic Message Channel) is a standardised coding system for traffic information. The receiver automatically searches for the correct frequency. Reception takes place via the FM antenna.

The coverage area of the system is under constant development which is why updates can sometimes be necessary, see page 24.

Irrespective of whether **Easy** or **Advanced** user settings are selected, traffic information transmitted is always received and presented. For more information, see page 62.

2 Speakers

Navigation system audio uses the front loudspeakers.

3 Keypad

The keypad is located on the right-hand rear side of the steering wheel. Use it to scroll between different menu options, to confirm selections or to move back in menus. For more information, see page 20.

4 Screen

The screen displays maps and provides detailed information on route type, distance, menus etc. For screen care, see page 24.

5 IR receiver

The IR receiver for the remote control is located in the audio system's control panel. For more information, see page 20.

Controls

Keypad location and IR receiver

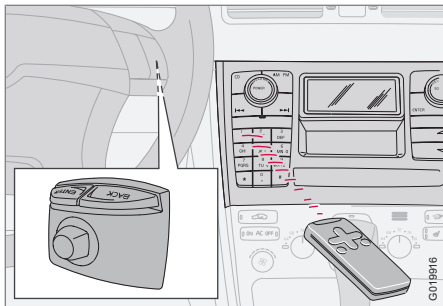

The navigation system is controlled with the steering wheel's keypad or the remote control.

The keypad is located on the right-hand rear side of the steering wheel.

Aim the remote control towards the IR receiver located on the loudspeaker grille adjacent to the screen or in the audio system's control panel (XC90 only).

NOTE

The remote control contains AAA or R03 batteries. Try changing to new batteries first if the remote control does not work.

Keypad, steering wheel/remote control

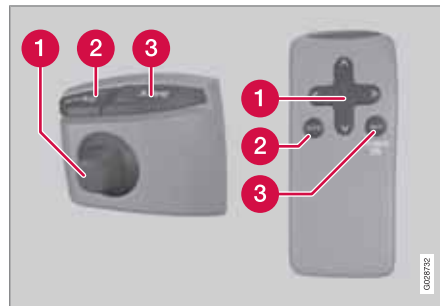

The steering wheel keypad and the keypad on the remote control have the same functions. Use the keypad to scroll through different menu options, confirm selections or move back in menus.

The design may vary for different models.

1 Navigation button

Scroll between different menu options using the **navigation button** , the keypad's locating pin or the remote control's arrow keys , , and . The navigation button also moves the cursor (hairline cross) on the map.

2 ENTER

Confirms or activates selections.

3 BACK

Undoes the most recent selection or goes back in the menu structure.

"Do not disturb"



In some situations, the system requires a few extra seconds to make a calculation. A symbol is then displayed on screen.

NOTE

When the calculation symbol appears, the system is unable to accept any commands from the **navigation**, **ENTER** or **BACK** buttons.

Entering and selecting options



The keyboard is used in many places within the menus for entering specific information, e.g. type of facility, country, city, street address, street or post code.

1. Select the letters using the **navigation button** and press **ENTER**.
 - > When there are no further alternatives the remaining letters in the name are entered automatically.

The list at the bottom of the screen shows the first three possible alternatives matching the letter input.
2. It is also possible to scroll down using **V** to directly access alternative names on the list.
3. Select the alternative and press **ENTER**.

The scroll bar on the right-hand side of the list shows that there are more alternatives in the list than those shown on the screen. The number (110) indicates the number of options.

1. Return to the character chart from the list of alternatives using **BACK**.
2. Delete the input letters entered one at a time using **BACK**.

General search

The search function is always available and always works in the same way irrespective of menu status when a location is entered.

If **ENTER** is pressed during an input then all reply combinations are shown for each respective alternative: City, street, facility etc.

For example, if a search is made for a name such as London Airport then all London combinations will be shown when **LO** is input. The more letters you input the more specific the reply.

A search for **LO** also provides reply alternatives such as Restaurant **Lou** Trivalou for example, as alternatives containing several words separated by spaces are included in the search.



01 Get to know your navigation system

01

Display modes and voice messages

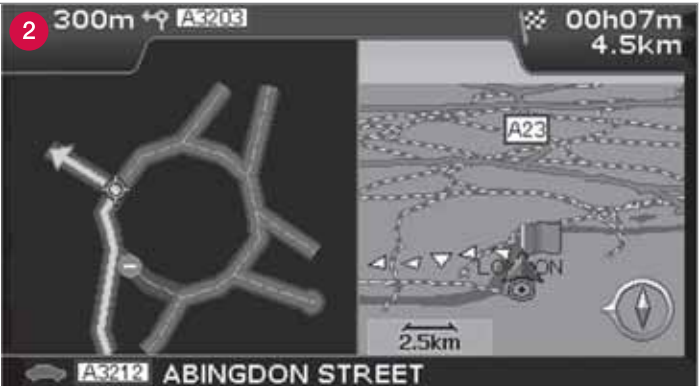
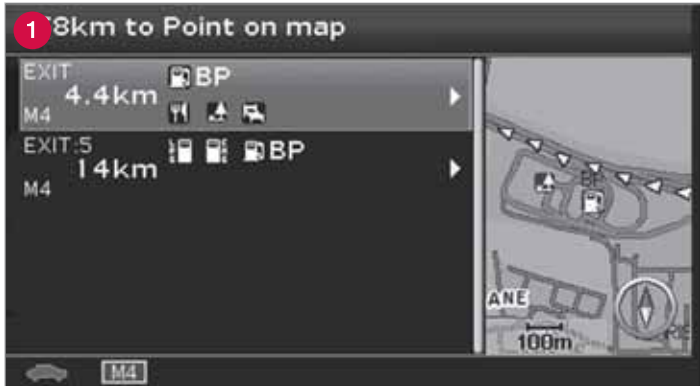

Display modes and voice messages

Different display mode appearances

The appearance of the screen image depends on geographic position and the settings made, e.g. map scale, symbols selected for display etc.

Explanations for the text, signs and symbols that may appear on the screen are available on the inside of the cover.

- 1 Facilities along the motorway. This function is available even if a destination has not been entered. Only shown when driving on the section of motorway in question. Press **ENTER** on the symbol for Facilities on the far right on the Quick menu, see page 39.
- 2 Detailed junction map. The left-hand section of the screen enlarges the navigation at the next junction. (Alternative navigation options are only shown for major roads.) The situation is always supplemented by a voice message.
- 3 Two maps can be selected as display mode. The screen shows the same map image but in two different scales. Shown following **ENTER** on the symbol for Map/Route outline in the Quick menu, see page 38.
- 4 Scroll mode, see page 28 and 40.

Voice messages

After a destination has been set, Guidance is activated and when a junction or exit is approaching the system generates a voice message stating distance and type of manoeuvre. At the same time a detailed map of the junction is displayed. The voice message is repeated closer to the junction.

Guidance with voice messages can be obtained at any moment using **ENTER** on the Quick menu's symbol for Guidance, see page 28 and 38.

NOTE

In some cases, e.g. for calls on the car phone, the voice message is replaced with a ping.

Toll roads

Some areas include toll roads. When a toll booth is approaching, a voice message indicates this.

A destination must be input in order to receive the message.

Compass

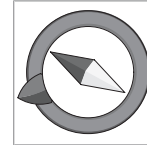

The map image can show the compass in two different ways:

- With the compass direction north always facing up.
- With the direction of travel always facing up.

always facing up.

The red tip of the compass needle points north on the map and the white tip points south.

The grey destination arrow in the outer ring of the compass points in the direction of the selected destination.

Go to **Settings** → **Map options** → **Map orientation** to select how the map direction is to be displayed and to **Compass** to select how the compass is to be displayed, see page 56.



01 Get to know your navigation system

01

Main unit, updating, maintenance

Contents in main unit

All map information is pre-installed on the main unit hard disk. There is no DVD disc in the unit at delivery. A DVD disc is not used until a map data update, refer to the package's instructions.

DVD discs with updated and additional information are issued regularly. Contact a Volvo dealer for the latest issue.

See also www.volvocars.com/navi for further information on maps etc.

If you encounter any errors or other issues with your maps, we recommend that you contact map supplier NavTeq directly: see www.navteq.com.

NOTE

The main unit's DVD player is designed for Volvo's map discs.

Screen care

Clean the screen with a soft, lint-free rag, lightly moistened with clean water or mild window cleaning agent.

Care of DVD discs

Handle DVD discs with care. When they are not in use they must be stored in their packaging. Avoid storing them in damp, excess heat, direct sunlight or dusty surroundings.

Updating with DVD disc

NOTE

Make sure that the car's electricity supply is secure because an update can take up to about 2 hours.

If the DVD disc, apart from new map discs, contains new software then this part starts first.

The car can be driven while map information is being updated but the system cannot be used while the update is in progress.

1. Switch on the system.
2. Eject any DVD disc that is loaded in the unit.

3. Load the DVD update disc. If there are several discs then load them in numerical order.
4. The system now updates automatically. The information shown indicates progress achieved.
5. After the update the DVD disc with the latest update must remain in the unit. If there is more than one disc then disc no. 1 must be used. If the disc is removed from the main unit then the system ceases to function.

If the system is switched off while the update is in progress then it continues automatically next time the system is activated.

In some cases map information updates can add new functions to the system.

When the update is finished the start screen is displayed.

Interrupted update

If an update is interrupted then it can be resumed. During the subsequent start-up, select the **Resume map update** option in the Navigation menu.

The update then resumes, not from the start, but from where the system detects that the update was interrupted.





Menus.....	28
Menu tree.....	30
Set destination.....	31
Show/Delete destination.....	34
Settings.....	35

02

EASY USER MODE





02 Easy user mode

Menus

General

When the navigation system starts up the required user settings are selected **Easy**.

In **Easy** mode, only the most important menus containing the most common functions are accessible.

Main menu



The main menu is at the top of the menu tree and can be reached by pressing the **BACK** key several times.

It is possible to switch from **Easy** to **Advanced** user settings in the main menu under: **Settings** → **System options** → **User mode**.

Quick menu



The most common functions are collected together in the Quick menu, which makes them easier to access while driving.

1. Press **ENTER** in Map mode.
2. Select a symbol using **<** or **>**.

Most system settings can be made under **Settings** in the Main menu while others can only be accessed via the Quick menu.

– Map scale

A menu containing two options is displayed.

Pressing **ENTER** on the options (+) or (-) changes the map scale in various stages, from 50 metres up to 100 km, to give you a greater perspective or allow you to see more details. Stepless changing is possible if you hold down **ENTER** - release the button when the scale is suitable.

– Guidance

Pressing **ENTER** provides current voice guidance.

Traffic information¹

Irrespective of whether **Easy** or **Advanced** user settings are selected, traffic information transmitted is always received and presented. For more information, see page 53 or 62.

Scroll menu



Map scroll

In Scroll mode, a hairline cross is manoeuvred over the map image.

- Activate Scroll mode (Scroll menu) by scrolling with the **navigation button**.

The longer you hold down the button, the faster the hairline cross moves across the map.

Menu

- Press **ENTER** in Map scroll mode to view the Scroll menu.

¹ Does not apply to all areas/countries.



Scale

Changes the size of the map image to provide a larger perspective or more detail.

Pressing **ENTER** on the options (+) or (-) changes the map scale in various stages, from 50 metres up to 100 km.

Stepless changing is possible if you hold down **ENTER** - release the button when the scale is suitable.

Set as destination (Set as destination)

Selects the location marked by the hairline cross as a destination by pressing **ENTER**. Guidance starts immediately.



Menu tree

Menu options

Shown here are three of the menu tree's levels. Several of the menus at level three have further submenus - these are described in more detail in their respective sections.

Set destination	page 31
→ Address	page 31
Country	
City	
Street	
No.	
Intersection	
→ Facilities	page 32
Country	
City	
Type	
Name	
→ Last 20	page 32
→ Point on map	page 33

Show destination	page 34
Delete destination	page 34
Settings	page 35
→ Guiding voice	page 35
Female/Male	
→ Guiding volume	page 35
Off/1/2/3/4/5	
→ Language	page 35
→ Map & menu colour	page 35
Black/Chrome/Blue/Dark	
→ Map view	page 35
2D/3D	
→ Distance unit	page 35
km/Statute mile	

→ User mode	page 35
Simple/Advanced	
Shut down	page 9



Set destination

Address



Set destination → Address



Enter street address

The system places the cursor on **Street** (**Street**) first. The last **Country** (**Country**) selected is preselected.

If not:

1. Scroll to **Country** (**Country**) and/or **City** (**City**) and press **ENTER**.
2. Or choose from the latest options selected by pressing **>**.

(For information on how the keyboard is used, see page 21.)

NOTE

The system starts with **Street** in order to avoid misunderstanding when two nearby cities/localities have grown together.

Alternatives 1

- Select **Street** (**Street**) without selecting a city.

If the street appears in several cities, a list will be displayed offering you alternatives to choose from. The system guides you to the middle of the street selected.

Alternatives 2

1. Start by selecting **City**
2. Then select **Street**.

NOTE

The definition of city or area may vary from country to country and even within the same country. In some cases, it refers to a municipality and in others it refers to a district.

No street addresses have been entered in the system for small locations. It is always possible to choose the centre of the place as a destination.

Specify street number

If the selected address has a street number, this can be entered in order to specify the destination more precisely.

1. Scroll to the line for **Number** after entering the street address, then press **ENTER**.
 - > Alternative street numbers are displayed.
2. Enter the required street number.
3. Scroll to **Select** and press **ENTER**.
 - > The address selected appears in the itinerary.
4. The cursor appears on **Start** - press **ENTER** again.
 - > Route indication starts.

Alternatively:

- Scroll to **Start** and press **ENTER**.



02 Easy user mode

Set destination

> Route indication starts immediately.

If the street number is not specified then the system guides to the middle of the selected street.

Select

Confirms input number.

Cancel

Go back to previous screen.

Enter a junction

Start guidance

- Scroll to **Start guidance** to start the guidance.

Search by post code

Set destination → Address → City

Instead of searching in a city, you can choose to search within a postcode area.

1. Select **City** and press **ENTER**.
2. Scroll to **Post code** and press **ENTER**.
3. Select digits and press **ENTER**, or select from the list of alternatives.
4. Scroll to **Street** to choose from addresses with the selected postcode, then press **ENTER**.

5. Scroll to **Start guidance** for guidance to the destination.



NOTE

This also applies when searching for facilities.

Search by facilities



Set destination → Facilities



Facilities is a collective name for petrol stations, hotels, restaurants, Volvo dealers, hospitals, car parks etc.

- Press **ENTER** to access a submenu with different search options in order to set a facility.

Country (Country)

- Enter and select country and press **ENTER**.

City (City)

- Enter and select city and press **ENTER**.

Type (Type)

- Enter and select type of facility and press **ENTER**.

Name (Name)

- Enter the name of a facility, or select from among the alternatives in the menu.

The list only displays the facilities in the selected city/selected area.



Set destination

Select from among the last 20

Set destination → Last 20

A list of the twenty most recent destinations is displayed.

- Scroll to the desired destination using **➤** or **ENTER** to access the submenu.

Set as destination

Adds the destination to the itinerary.

Delete location

Deletes the location from the list **Last 20**.

Location on map

Set destination → Location on map

1. Use the **navigation button** to move the hairline cross to the required destination and press **ENTER** to access the Scroll menu, see page 28.
2. Scroll to **Set as destination** and press **ENTER**.

NOTE

It is also possible to search for a location on the map directly with the crosshair by using the **navigation button** in Map mode.



Show/Delete destination

Show destination on map

Show destination

- Press **ENTER** to obtain a map overview of the area you set as final destination.

Delete destination

Remove destination

1. Press **ENTER** to reach the destination to be deleted.
2. Press **ENTER** again to delete the destination.



Guiding voice

Settings → Guiding voice

Set female or male guiding voice¹.

Guiding volume

Settings → Guiding volume

Select the volume of voice messages, or switch them off completely.

Language

Settings → Language

Set language for menus, text and voice messages.

Colour

Settings → Colour

There are four screen display settings - select the one that suits you best.

Map view

Settings → Map view

The map can be displayed in **2D** (from directly above) or **3D** (obliquely from above).

Distance Unit

Settings → Distance Unit

Select whether distance should be shown in km or **UK-mile**.

User mode

Settings → User mode

Switch between **Easy** and **Advanced** user settings.

¹ Not applicable to the Netherlands. Instead there is the choice of language between **Nederlands** and **Belgisch**.



Menus.....	38
Menu tree.....	42
Set destination.....	44
Itinerary.....	49
Current position.....	52
Traffic information.....	53
Settings.....	54
Simulation.....	59

03

ADVANCED USER MODE





Menus

General

When the navigation system starts up the required user settings are selected **Advanced**.

Access to all of the navigation system's settings and functions is available in the **Advanced** mode.

Main menu



The main menu is at the top of the menu tree and can be reached by pressing the **BACK** button one or more times.

It is possible to switch from **Advanced** to **Easy** user settings in the main menu under:

Settings → System options → User mode

Quick menu



The most common functions are collected together in the Quick menu, which makes them easier to access while driving.

1. Press **ENTER** in Map mode.
2. Select a symbol using **<** or **>**.

Most system settings can be made under **Settings** in the Main menu while others can only be accessed via the Quick menu.

Fast storage of current location

You can save the location of your car to the map at any one time at the touch of a button.

- Press **ENTER** - hold down the button until the display changes.



Your location will then be stored, as indicated by this symbol. Information linked with the position is adjusted via **Stored location → Edit**, see page 46.



- Route outline/Scale

A menu containing four options is displayed.

Pressing **ENTER** on the option at the top displays a map showing the remaining route out-

line¹ from the current position to the destination.

Pressing **ENTER** on the second option displays a map showing the entire route outline¹ from start to destination.

Pressing **ENTER** on the options (+) or (-) changes the map scale in various stages, from 50 metres up to 100 km, to give you a greater perspective or allow you to see more details.

Stepless changing is possible if you hold down **ENTER** - release the button when the scale is suitable.

If you opt to display two maps, the map scale symbol appears at either end of the Quick menu so that you can adjust the relevant scale individually.



- Guidance

Pressing **ENTER** provides current voice guidance.



- Map/Route outline

Route outline

Pressing **ENTER** displays a list of approaching waypoints. The distance between waypoints and type of manoeuvre are displayed in addition to the road name.

¹ A route must be selected.



One map/Two maps

Pressing **ENTER** displays one large or two smaller map images of the current area. Different scales may be input for the respective maps.

Surveillance²

Allows you to save map views of three different monitoring areas, e.g. roads with high traffic densities that are often subject to traffic problems.

Select **Surveillance.1, 2 or 3**. To view previously set surveillances, see page 40.



– Diversion

Displays a menu with **Avoid** and the options **1-5-10-20-40-80 km**.

Avoid streets/roads

This function deselects streets or roads from an itinerary set up so that you do not have to drive through a known roadworks area, for example.

1. Select **Avoid** in the Diversion menu and press **ENTER**. A list of streets/roads included in the route outline is shown.
2. Scroll to the street/road to be avoided and press **ENTER**.

3. If several streets/roads are to be avoided, start by scrolling using **V** to the first street/road in the group to be avoided, then press **ENTER**. Then scroll to the last street/road in the group to be avoided and press **ENTER**.

The system then calculates, as far as possible, a new route outline which leads back to the original route outline only once the specified stretches have been avoided and passed.

Avoid stretch within 1-80 km

This function deselects an entire area in the original itinerary so that you do not have to drive through a densely populated area in rush hour, for example.

- Select an option from the diversion menu **1-80 km** and press **ENTER**.

The system then calculates, as far as possible, a new route outline which leads back to the original route outline only once the specified area has been avoided and passed.

It is also possible to avoid an area by marking a square area directly on the map, see **Avoid specified areas** under

Settings → Route options

on page 54.



– Traffic information³

Displays a menu containing different options for viewing information on traffic problems within the area displayed on screen.

A change in the scale affects the number of messages shown, see page 66.

Read message

Pressing **ENTER** allows you to scroll through the traffic messages displayed on screen.

Show all

Pressing **ENTER** displays all messages.

Hide all

Pressing **ENTER** hides all messages.

Show selected

Pressing **ENTER** allows you to select the type of traffic messages to be displayed in the map.

Irrespective of whether **Easy** or **Advanced** user settings are selected, traffic information transmitted is always received and presented. For more information, see page 62.



– Facilities

Displays a menu containing various options for searching for a facility.

² Only in areas that can receive traffic information.

³ Does not apply to all areas/countries.



Menus

Around the car

Pressing **ENTER** allows you to search around the car. See page 45

Along the route

Pressing **ENTER** allows you to search along the route. See page 45

Along the motorway

Pressing **ENTER** allows you to search for rest areas, petrol stations and restaurants that are readily accessible along the motorway.

If a calculated route extends over several motorways then the system only searches along the section of motorway currently being used.

Scroll menu

Map scroll

In Scroll mode, a hairline cross is manoeuvred over the map image.

- Activate Scroll mode (Scroll menu) by scrolling with the **navigation button**.

The longer you hold down the button, the faster the hairline cross moves across the map.

Menu



- Press **ENTER** in Map scroll mode to view the Scroll menu.

Scale

Changes the size of the map image to provide a larger perspective or more detail.

- Pressing **ENTER** on the options (+) or (-) changes the map scale in various stages, from 50 metres up to 100 km.
- Stepless changing is possible if you hold down **ENTER** - release the button when the scale is suitable.

Set as destination (Set as destination)

Selects the location marked by the hairline cross as the destination.

- Press **ENTER**. Guidance starts immediately.

Facilities around (Facilities around)

A menu is displayed.

- Choose between the **Last 5** and **All types** to search for facilities within the local area.

Read traffic msg. (Read traffic msg.)

Searches for current traffic messages within the area.

Surveillance (Set for surveill.)³

Pressing **ENTER** displays a menu containing various options.

- Select between **Surveillance 1, 2 or 3** and press **ENTER** to store a map view you want to save as a surveillance area, e.g. heavily trafficked roads that are often subject to traffic problems.

Activating the map

Selects map options in the Quick menu.

- Select required surveillance.

Store location (Store location)

Saves a selected location, which then appears under:

Set destination → Stored locations

³ Does not apply to all areas/countries.



Follow route in itinerary

To be able to easily follow a set route in the itinerary, there is a built-in "magnet function" where - regardless of how the route outline turns and changes compass direction - the hairline cross follows the route outline automatically by simply holding down a button.

One of the lines on the hairline cross indicates which button is to be selected - it appears "fatter" than the other one.



The route outline is followed automatically using button **<** or **>**.



The route outline is followed automatically using button **▲** or **▼**.

If no "magnet function" is required, the "fat" hairline cross line disappears when you scroll the hairline cross a few millimetres off the selected itinerary. The scroll function then returns to normal.



Menu tree

Menu options

Shown here are three of the menu tree's levels. Several of the menus at level three have further submenus - these are described in more detail in their respective sections.

Set destination	page 44
→ Address	page 44
Country	
City	
Street	
No.	
Intersection	
→ Facilities	page 32
Facility by name	
Around the car	
Along the route	
Around point on map	
Along a street	

→ Stored locations	page 46
Add to itinerary/Information/Sorting/Delete location	
→ Last 20	page 47
Add to itinerary/Information/Delete location/Del. all	
→ Return trip	page 47
View Itinerary	
→ Point on map	page 47
→ Latitude/longitude	page 48
Itinerary	page 49
→ Start guidance	page 44
→ Add to itinerary	page 49
View Address under Set destination	

→ Route options	page 54
View Route options under Settings	
→ Clear itinerary	page 49
Next destination	page 44
→ Address	page 44
View Address under Set destination	
Current position	page 52
Settings	page 53
→ Traffic information	page 53
Dynamic route guidance	
Traffic-info. selection	
Search stations	
Reset to default	



→ Route options Route Avoid motorways/toll roads/ferries/car trains/traffic problems/time-restr. roads/specified areas Reset to default	page 54	→ System options Guiding voice Guiding volume Language Menu colour Map colour Screen saver Help Distance unit User mode Date & time info GPS information About Reset to default	page 57
→ Map options Facility selection Map Right map view Left map view Compass Current location Reset to default	page 55	→ Start demo	page 59
→ Guiding options Time/dist. to go Facility warning Charge area warning Reset to default	page 56	Shut down	page 9



Set destination

Address



Set destination → Address



Enter street address

The system places the cursor on **Street** (**Street**) first. The last **Country** (**Country**) selected is preselected.

If not:

1. Scroll to **Country** (**Country**) and/or **City** (**City**) and press **ENTER**.
2. Or choose from the latest options selected by pressing **>**.

(For information on how the keyboard is used, see page 21.)

NOTE

The system starts with **Street** in order to avoid misunderstanding when two nearby cities/localities have grown together.

Alternatives 1

- Select **Street** (**Street**) without selecting a city.

If the street appears in several cities, a list will be displayed offering you alternatives to choose from. The system guides you to the middle of the street selected.

Alternatives 2

1. Start by selecting **City**.
2. Then select **Street**.

NOTE

The definition of city or area may vary from country to country and even within the same country. In some cases, it refers to a municipality and in others it refers to a district.

No street addresses have been entered in the system for small locations. It is always possible to choose the centre of the place as a destination.

Specify street number

If the selected address has a street number, this can be entered in order to specify the destination more precisely.

- Scroll to the line for **Number** after entering the street address, then press **ENTER**.

If the street number is not specified then the system guides to the middle of the selected street.

Alternatively:

1. Enter the required street number.
 - > Alternative street numbers are displayed.
2. Scroll to **Select** and press **ENTER**.

Cancel

Go back to previous screen.



Set destination

Enter a junction

- Scroll to **Intersection (Junction)** and select a street which intersects the street selected.

Start guidance

1. Scroll to **Start guidance** to start the guidance.
2. Scroll to **Select** to add the input address to the itinerary.

Information

Provides information about the destination.

Search by post code



Set destination → Address → City

Instead of searching in a city, you can choose to search within a postcode area.

1. Select **City** and press **ENTER**.
2. Scroll to **Post code** and press **ENTER**.
3. Select digits and press **ENTER**, or select from the list of alternatives.
4. Scroll to **Street** to choose from addresses with the selected postcode, then press **ENTER**.
5. Scroll to **Start guidance** for guidance to the destination.

NOTE

This also applies when searching for facilities.

Search by facilities



Set destination → Facilities

Facilities is a collective name for petrol stations, hotels, restaurants, Volvo dealers, hospitals, car parks etc.

- Press **ENTER** to access a submenu with various search options for specifying facilities.

Facility by name (Facility by name)

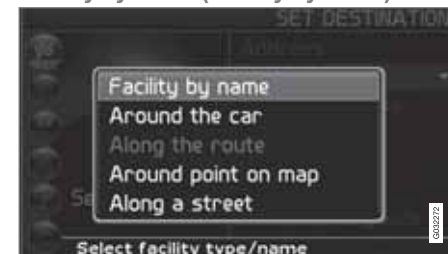

- Enter the name of a facility, or choose from the alternatives in the menu.

The list only displays the facilities in the selected city/area.

Around the car (Around the car)

Search **Last 5** or **All types**.

The system searches for facilities around the car (max. 100 km radius). The search is stopped after 40 facilities have been found.

Along the route (Along the route)

Search **Last 5** or **All types**.



Set destination

When a destination has been specified, the system can search for facilities in an area along the route (within 1 km of the route).

Around point on map (Around point on map)

The system searches in the same way as **Around the car**, but around a chosen point on the map.

1. Move the crosshairs on the map using the **navigation button**.
2. Press **ENTER** to access the Scroll menu.

Along a street (Along a street)

The system searches along a specified street.

NOTE

It is also possible to search for facilities around the car, along the route, or along a motorway via the Quick menu, see page 28.

Facility types/Different categories

Set destination → Facilities → Facility by name

The system places the cursor on **Type** first. The last **Country** selected is preselected.

If not:

1. Scroll to **Country** and/or **City** and press **ENTER**.
Or choose from the latest options selected by pressing **>**.
2. Scroll to **Name** and press **ENTER** to enter a facility name without specifying a city.
3. Scroll to **Select** and press **ENTER**.
4. Then scroll to **Start guidance** and press **ENTER** for guidance to the destination.

NOTE

To refine the search, select City first and then scroll to Name.

There are sub-categories for e.g. restaurants to simplify searching.

Information on facility

Information shows the address, coordinates and - in some cases - telephone number of the facility. If the car is equipped with built-in phone then the function **Call** is also activated.

Call

The telephone dials the number specified.

Map

Displays the location of the facility on the map.

Other facilities

Airports, for example, often have restaurants, petrol stations, etc. directly next to the airport.

Instead of searching on Restaurants in the main menu, you can select Restaurants directly for the Airport selected.

Avoiding alternatives off-airport simplifies your search and makes it faster.

Stored locations

Set destination → Stored locations

Stored location is a destination saved previously, e.g. home address, favourite restaurant, airport, Volvo dealer. Information on how to store a location, see page 50.

- Scroll between the stored locations and press **>** or **ENTER** to access the sub-menu.

Add to itinerary

Adds the stored location to the itinerary.

Information

Provides information about the stored location.

Edit

Change name, add sound, etc. for a stored location. See under the following heading, Add information on stored location.

**Set destination****Sorting**

Sort stored locations according to icon or name.

Delete location

Deletes a stored location.

Delete all

Deletes all stored locations.

Move the position of a stored location

1. Select **Edit**, scroll with **➤** to **Adjust** and press **ENTER** in order to specify a new position on the map for the stored location.
2. Move the crosshairs to the new position using the **navigation button**, then press **ENTER**.
3. Then select **Store location** and press **ENTER** to save the location.

Add information on stored location

- Select **Edit**, scroll with **➤** to **Add info.** and press **ENTER** to add further information on the stored location.

Every stored location can be provided with the following information:

- Alarm On/Off (...to notify the driver of his/her approach to the location)
- Icon
- Name

- Address
- City
- Country
- Tel.
- E-mail
- URL

Choose from the last 20

Set destination → Last 20

A list of the twenty most recent destinations is displayed.

- Scroll to the desired destination using **➤** or **ENTER** to access the submenu.

Add to itinerary

Adds the destination to the itinerary.

Information

Provides information about the destination.

Delete location

Deletes the location from the list **Last 20**.

Delete all

Deletes all addresses from the list **Last 20**.

Return trip

Set destination → Return trip

- Select **Start guidance** and press **ENTER**.

The system then starts guidance back to the location where **Start guidance** was last selected.

Search via point on map

Set destination → Location on map

1. Use the **navigation button** to move the crosshairs to the required destination, then press **ENTER** to access the Scroll menu.
2. Select **Set as destination**, see page 40.

**NOTE**

It is also possible to search for a location on the map directly with the crosshair by using the **navigation button** in Map mode.



Set destination

Search via latitude/longitude

Set destination → Latitude/longitude

1. Select a destination by entering the coordinates for the destination.
2. Enter a latitude using the **navigation button**: select **N** for north or **S** for south.

NOTE

London is at longitude 0 (zero). Points west of London's longitude are indicated by W (West) and points east of it are indicated by E (East).

3. Scroll to the next line and specify longitude: select **E** for easterly or **W** for westerly.
Press **OK**
> Shows the location of the specified coordinates on the map.
4. Press **ENTER** to reach the Scroll menu.
5. Scroll to **Set as destination** and press **ENTER** to select the location as a destination.
6. Press **BACK** to return to coordinate input.

Cancel

Return to previous screen.



Itinerary

Create an itinerary



Destination/intermediate destination

The menu option **Itinerary (Itinerary)** can be accessed only when you have input an itinerary.

Create an itinerary with several waypoints to avoid entering destination after destination during your trip. One final destination with up to six waypoints can be specified in an itinerary.

Start guidance (Start guidance)

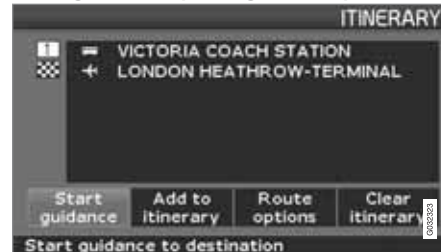

Itinerary

Starts guidance to the destination.

Add to itinerary (Add to itinerary)

Additional waypoints are added to the itinerary here, see page 44.

Route options (Route options)

Route prioritising options, see page 54.

Clear itinerary (Clear itinerary)

Deletes the whole itinerary.

Itinerary layout



Itinerary

- Select an input destination and press **ENTER** or **>** to access the submenu.

Information (Information)

Provides information about the destination.

Delete (Delete)

Deletes the destination from the itinerary.

Move (Move)

Changes the location of the destination in the itinerary.

Adjust (Adjust)

Changes the location of the destination on the map.

Store (Store)

Saves the destination that will be available under **Stored locations**.



Itinerary

Delete from itinerary

Itinerary

Delete the whole itinerary

All waypoints and the final destination are deleted.

- Scroll directly to **Clear itinerary** and press **ENTER**.

Delete intermediate destination in the itinerary

1. Select one of the input intermediate destinations and press **ENTER** or **>** to access the submenu.
2. Scroll to **Delete** and press **ENTER**.

NOTE

Passed waypoints are automatically deleted from the itinerary.

Store for re-use

Up to 250 destinations can be stored for re-use in different itineraries.

An acoustic signal that alerts the driver to the fact that the stored location is approaching, plus other information can be linked to the stored location, see page 47 - Add information on stored location.



Itinerary

Save a location from the itinerary

1. Use the **navigation button** to step through to the destination you want to store, then press **ENTER** or **>** to access the submenu.
2. Select **Store** and press **ENTER**.
3. Use the **navigation button** to select a symbol to be displayed on the map, then press **ENTER**.
4. Enter the required name.
5. Scroll to **Store Store** and press **ENTER**.

Save a location on the map

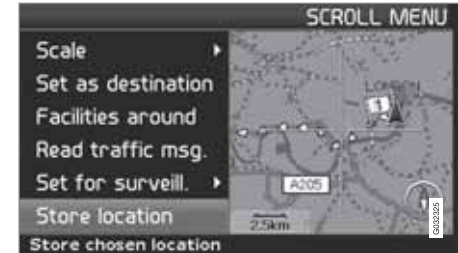

Scroll menu

1. In Scroll mode, use the **navigation button** to step through to the point to be stored, then press **ENTER**.
2. Select **Store location** **Sore location** from the Scroll menu, then press **ENTER**.
3. Use the **navigation button** to select a symbol to be displayed on the map, then press **ENTER**.
4. Enter the required name.
5. Scroll to **Store** and press **ENTER**.

A current location can also be stored quickly while driving, for example, at the touch of a button, see page 38 - Fast storage of current location.



Itinerary

Next destination in itinerary



Next destination



The map image shows the next destination.

1. Press **ENTER** or **>** to view information on the destination such as the name, time to destination or distance from current position to destination.
2. Press **ENTER** if several destinations are presented in order to view information and see them on the map.
3. Step through to **MapMap** and press **ENTER** to view the map of the area.



Current position

Current position



GPS

Specifies the number of satellites the system is in contact with.

Current position



The map image shows the car's position.

- Press **ENTER** or **➤** to obtain information on the location, such as name and coordinates for example.



Traffic information



Settings → Traffic information

Irrespective of whether **Easy** or **Advanced** user settings are selected, traffic information transmitted is always received and presented. For more information, see page 62.

NOTE

Traffic information is not available in all areas/countries.



Settings

Route options



Settings → Route options

1. Scroll between the functions, select the required setting and press **ENTER** to save the settings.
2. Press **BACK** to cancel.



Route

Select a fast, short or simple route when calculating a route.

- **Fast:** As far as possible the system prioritises major roads with high speed limits.
- **Short:** As far as possible the system prioritises the nearest road.
- **Easy:** As far as possible the system prioritises roads that do not involve complicated manoeuvres and junctions.

NOTE

When calculating a route, the system as far as possible takes consideration of the alternatives the driver has chosen to avoid. However, an exception is made if no reasonable alternative is available.

Avoid motorways

Indicate whether motorways are to be avoided when calculating a route.

Avoid toll roads

Indicate whether toll roads are to be avoided when calculating a route.

Avoid ferries

Indicate whether car ferries are to be avoided when calculating a route.

Avoid car train

Indicate whether car trains are to be avoided when calculating a route.

Avoid traffic problems

Indicate whether the system should give consideration to traffic problems when calculating a route.

Avoid time-restr. roads

- Select **Yes** if you want the system to completely avoid time-restricted roads when calculating a route.
- Select **No** if the system is to give consideration to time-restricted roads when calculating a route.

The system uses the time in the car's clock to determine whether a road should be avoided.

NOTE

If a time zone boundary is crossed then the car's clock must be adjusted.

Avoid specified areas

The function is for avoiding being guided through special areas, cities or districts. The system ignores the selected areas when calculating the route outline. The exception is motorways which are used for calculating even in an area selected to be avoided.



Settings



Settings → Route options → Avoid specified areas → Selected

Select the area that the itinerary should avoid by directly selecting on the map with a square field.

1. Call up the map by clicking with **>** on **Selected**, click with **>** on **Map** and then **ENTER** on one of the options in the list displayed.
 - > Scroll to the required area with the marker field, then press **ENTER**.
2. To change the size: Select **Adjust size** (**Adjust size**) and press **ENTER**.
 - > Change the shape of the marker field using the **navigation button** so that it covers the area to be avoided, then press **ENTER**.

In the same way, the marker field mode can be changed under **Adjust area** (**Adjust area**).

3. Select **Set area to avoid** and press **ENTER**.
 - > The selected area is saved to a list in which a number of areas can be stored and activated when required.
4. Agree to avoidance of the area with **ENTER** on **OK** and a cross in the list.
 - > The system will then, as far as possible, avoid this area in the itinerary.

The areas stored in the list can be adjusted in terms of size and geographical location under **Edit**, and they can be deleted permanently from the list with **Delete**. A number of activated areas can be deactivated simultaneously using the **None** option.

Reset to default

Restore factory settings for Route options.

- Press **>**, select **OK** and press **ENTER**.

Map options



Settings → Map options

Select here what facilities are to be displayed in the map and how the map is to appear on screen.

1. Select a function to be adjusted using the **navigation button**.
2. Press **ENTER** to open the function.

Facility selection

Press **>** to access the submenu's options.

- **Show all:** All facilities symbols are shown on the map image.
- **Hide all:** No symbols are shown.
- **Show selected:** Press **>** to view all symbols which can be shown on the map image. Then select symbols as follows:



Settings



1. Scroll through the symbols by pressing **▲** or **▼**.
2. Activate the required symbols with a cross with **<** or **>**.
3. Press **ENTER** to save.

Map

Choose between the options **Show** and **Hide**.

If the map is hidden, the system guides with an arrow.

Right map view

Select whether the map is to be displayed in 2D (from directly above) or 3D (obliquely from above).

- With the **3D** option, the heading is always upwards on the screen.
- With the **2D Heading** option, 2D is shown with the heading upwards on the screen

and the **2D North** option provides 2D with compass direction North always upwards.

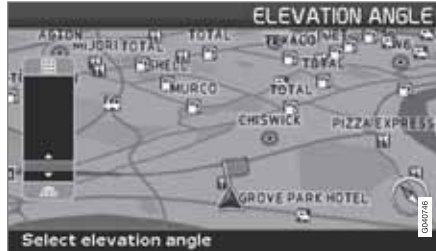

Selection of elevation angle.

Settings → Map options → Map view → 3D

After the selection of **3D** with **>** or **<** and **ENTER** the control for the elevation angle is displayed. Select the desired angle with **▲** or **▼** followed by **ENTER** and **BACK**.

Left map view

See the description in the previous section.

i NOTE

If 3D is selected for the map on the right, the map on the left can only display 2D.

Compass

Choose whether the compass is to be displayed on the screen.

Current location

Indicate whether the name of the street/road on which the car is currently driving should be shown at the bottom of the screen.

Reset to default

Restore factory settings for Map options.

- Press **>**, select **OK** and press **ENTER**.

Guiding options

Settings → Guiding options

Time/dist. to go

Select one of the alternatives **RTA/ETA/Hide**.

- **RTA** (Remaining Time to Arrival): Remaining time to arrival.
- **ETA** (Estimated Time of Arrival): Estimated time of arrival.

i NOTE

The time set on the car's clock controls the time indicated for **ETA**.



Charge zone warning

Besides road tolls with barriers or other blocking systems, there are also charge routes/zones without physical barriers, such as congestion charge areas.

Select **YesOn** if you require warnings of these types of road, otherwise select **NoOff**.

Facility warning



Safety camera.

The driver is alerted by means of an acoustic signal and a symbol that a safety camera is approaching. The symbol is orange if vehicle speed exceeds the permitted limit - otherwise it is white.

- Select **Yes** to hear an acoustic warning signal, or **No** if no signal is required.

NOTE

The type of information permissible for inclusion on the map is stipulated in national legislation. For current information, see www.volvocars.com/navi.

NOTE

- In certain regions the maximum permissible speed is not stated on the map in combination with a camera warning.
- Pay attention that the posted maximum permissible speed may sometimes be changed and accordingly deviate from the navigator's database.
- The driver always has the responsibility that the traffic and speed regulations in force are followed.

Reset to default

Restore factory settings for Guiding options.

- Press **>**, select **OK** and press **ENTER**.

System options

Settings → System options

1. Scroll between the functions using the **navigation button**, then press **ENTER** to save the settings.
2. Press **BACK** to cancel.

Guiding voice

Select the guiding voice you want as the setting: **Female/Male**¹.

Guiding volume

Set the volume for voice messages.

Language

Set language for menus, text and voice messages.

Menu colour

Select **Black**, **Chrome** or **Blue** for the appearance of the menus.

Map colour

Select **Bright 1**, **Bright 2** or **Dark**.

The light colours are intended for daylight and dark for night or in darkness.

Screen saver

Indicate whether the screen saver should be used (the screen goes out 30 seconds after the last keystroke).

¹ Not applicable to the Netherlands. Instead there is the choice of language between **Nederlands** and **Belgisch**.



Settings

Help

Indicate whether help texts should be displayed at bottom of the screen.

Distance Unit

Select the unit to be displayed for distance - km or statute mile.

User settings

Switch between **Easy** and **Advanced** mode.

Date & time info

Select how the date and time are to be displayed.

GPS information



The car's position and height above sea level (Altitude).

Press **>** to see coordinates and height above sea level for the car's position, as well as the number of satellites the system is in contact with.

NOTE

Information on height is displayed in increments of 10 m. All heights below 50 m ASL are displayed as <50 m.

About

Shows system and map information.

Reset to default

Restore factory settings for System options.

- Press **>**, select **OK** and press **ENTER**.



Start demo (simulation)

Settings → Start demo

Demo demonstrates the system when the car is stationary by simulating a journey to a specified destination.

It is also possible to make settings during the demonstration.

Stop demo stops the simulation.

NOTE

A destination must be entered in order for the demo to work.

General.....	62
Avoiding traffic problems.....	63
Selecting information.....	65
Reading information.....	66
Transmitters.....	67

04

TRAFFIC INFORMATION





04 Traffic information

General

Display and reception

Traffic information that is transmitted is always received and presented, irrespective of whether **Easy** or **Advanced** user settings are selected.

The settings for how traffic information should be presented can only be changed in **Advanced** mode, see page 38.

The presentation of traffic information also depends on how it is transmitted.

NOTE

Traffic information is not available in all areas/countries.

The traffic information transmission areas are constantly being expanded.

Traffic symbols on the map









Symbol for traffic message.

A symbol is shown in the upper left-hand corner of the map when there is at least one traffic message along the itinerary's route. The traffic problem can be scrolled forward using the **navigation button** in order to see its position and nature.

Traffic problems are marked with symbols, lines and frames. These are coloured red or yellow.

Red - Important information.

Yellow - General information.

	Accident
	Slow traffic
	Slow traffic in both directions
	Stationary traffic
	Area message
	Other information

Extent



Certain traffic messages also contain information on the extent of the traffic obstruction.

On all scales up to 5 km the extent is marked with a red or yellow line along the route affected. The length of the line corresponds to the extent (distance) of the traffic problem.



Avoiding traffic problems

Before guidance is started

Settings → Route options

In connection with entering a new itinerary in the navigator: Select whether or not the system should take into consideration traffic problems when the **Start guidance** function is activated, see page 49.

1. Set **Avoid traffic problems**.
2. Choose between **Yes** and **No**.

Yes

The system attempts as far as possible to avoid roads with traffic problems when the itinerary is activated.

No

The system does not avoid any roads with traffic problems when the itinerary is activated.

NOTE

When starting up the system it can take up to 15 minutes before all traffic information for the area has been loaded.

During the journey

Settings → Traffic information →
Dynamic route guidance

The system proposes another route if there is a suitable alternative, e.g. if a traffic message states that there is a traffic problem on the original itinerary.

Man/Sem-aut/Auto/Off

Choose how the system is to display an alternative route by selecting **Male/Sem-aut/Auto**, or shut down the function by selecting **Off**.

- **Manual**

Another route is suggested, regardless of whether it is better or worse - select/accept the suggested route, then a new itinerary will be used.

- **Semi-auto**

Another route is suggested, but only if it is better - select/accept the suggested route, then a new itinerary will be used.

- **Auto**

The system calculates and uses a new itinerary automatically if a better route exists.

- **Off**

The system does not display or calculate alternatives for better routes.

Messages along the route

One of the **Male Sem-aut** alternatives is selected in the preceding section and a traffic problem arises along the route:



If there is another route past the problem, the display shows the difference in distance and driving time:

Changed traffic situation, New route?:
600 m longer, 00h 09m faster.

(Changed traffic situation. Use new route?:
600m longer, 00h 09m faster).

- Select **Yes** or **No**.

Yes (Yes)

A new route is used - around and past the problem.



Avoiding traffic problems

No (No)

Guides up to and through the problem.

Show new route (Show new route)

Shows map with the new route highlighted.



Selecting information

Traffic-info. selection

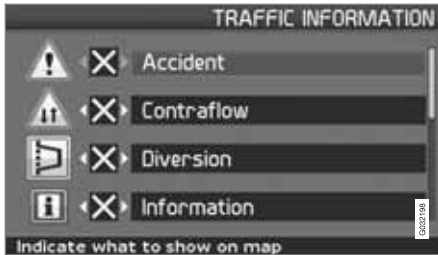

Select the type of traffic information the system should display and to be considered in the event of calculating a route.

Settings → Traffic information → Traffic info. selection

Show all

All traffic information is available.

Hide all

No traffic information is displayed.

Show selected

1. Press **>** to enable selection from symbols.
2. Select using **▲** or **▼** the traffic information symbols (traffic messages) the system should show on the map.

3. Activate and deactivate respectively using **>** or **<**.
4. Confirm the settings with **ENTER**.

Traffic signs on the map

	Accident
	Contraflow
	Diversion
	Information
	Narrow road
	Parking
	Congestion
	Roadwork

	Slippery road
	Other hazard



Reading information

Read traffic message



Detailed traffic information.

Read traffic msg.

A traffic message is indicated by a symbol on screen. To read a traffic message:

1. Press **ENTER** to call up the Quick menu:



2. Scroll to  using **<** or **>**, then press **ENTER**, see page 38 and 39.

> Current messages are marked with a red or yellow frame.

3. Browse forward or back using **<** or **>** and press **ENTER** for detailed traffic information (the illustration shows an example).

4. Press **BACK** to enable browsing between current messages again.

The traffic messages relevant to the map area are indicated on the screen.

Detailed information on the traffic problem is also shown. The extent of the problem is shown at the top. If the traffic problem is located along the selected route then the distance to it is specified.

If details are available, the following are also displayed:

- duration
- restrictions on speed, vehicle width and height
- roads affected.

Scale

The scale of the map determines how great a quantity of traffic information can be shown - the larger the map area shown on the screen, the more information is provided. For more information, see page 28.



Search/select station for traffic information

Settings → Traffic information → Search station

The system automatically searches stations for traffic information, but a specific station can also be selected.

Search stations

- Press **ENTER** to search for existing stations.

Select station

1. Press **ENTER** to select from among existing stations.
2. Select station using **▲** or **▼** and press **ENTER**.
3. Press **BACK** to return to the previous screen.

Current station

Shows the current station for traffic information.

Reset to default

Restore factory settings for station settings.

- Press **➤**, select **OK** and press **ENTER**.

Landmarks and road numbers..... 70

Symbols for facilities..... 71

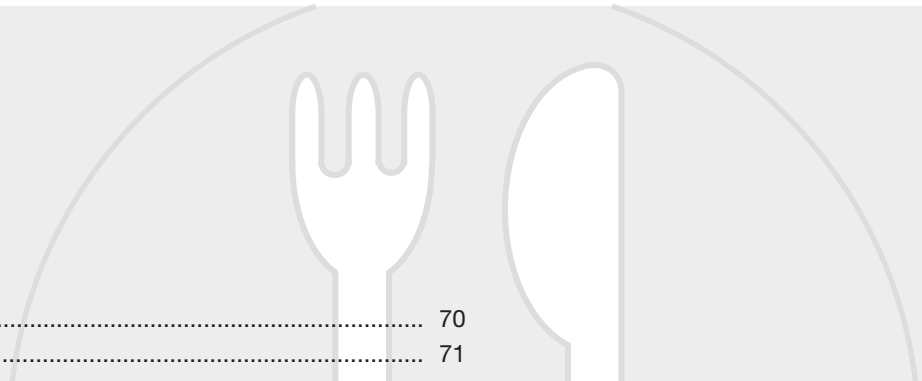

05

SYMBOLS ON THE MAP





05 Symbols on the map

Landmarks and road numbers

Landmarks

Many countries/cities have well known landmarks that can be used as target points.

When the map scale is set to 1 km or lower then a selection of landmarks is shown e.g. churches and castles.

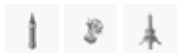

NOTE

Landmarks are only available for Europe.

Facilities

Facilities → Map options → Facility selection

Select facilities to be shown on map.

Road numbers

Local road numbers and international numbers are shown on the map.



Mountain peaks

Mountain peaks shown on the map scale are set at 5 km or lower (only applies to particular areas).



Symbols for facilities

Select whether all or no facilities should appear on the map or specify which should be shown.

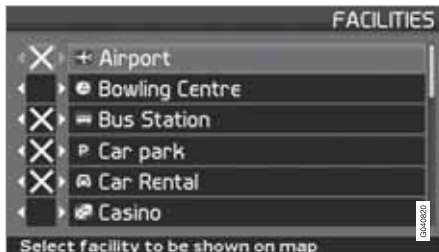

(Settings → Map options → Facility selection)

Settings → Map options → Facility selection













1. With **Facility selection (Facility selection)** selected, press **>** - a menu opens.
2. Select **Show selected (Show selected)** and press **>** - a new menu opens.
3. Facilities marked with a cross are displayed on the map - scroll through the list and uncheck the **>** the symbols not to be displayed.
4. Finish with **ENTER** when all selections have been made - exit the menus with **BACK**.

NOTE

The symbol for a facility may vary between different countries.

The following symbols for the different facilities can be chosen to appear on the display screen.

	Embassy
	Pharmacy
	Bathing beach
	Bank

	Petrol station
	Library
	Automobile club
	Car hire
	Car workshop
	Cinema
	Book store
	Bowling
	Fire brigade
	Bus station
	City centre
	Court house
	Airport

Symbols for facilities

	Recreation area
	Recreation area
	Ferry terminal
	Liquid petroleum gas
	Golf course
	Sacred edifice
	Historical monument
	Hotel
	Sports complex
	Industrial zone
	Ice skating
	Train station
	Coffee shop























	Casino
	Dry cleaners
	Civic/community centre
	Concert hall
	Art museum
	County council
	Grocery shop
	Doctor
	Medical service
	Hamlet
	Monument
	Museum
	Authority

	Convention/exhibition centre
	Night life/music club
	Compressed natural gas
	Amusement park
	Public sport airport
	Accident site
	Parking
	Parking garage
	Park & ride
	Commuter train station
	Guest house
	Police station
	Post office

05



Symbols for facilities

	Rest area		Tourist attraction
	Restaurant		Tourist information
	Town hall		Railway station
	Shopping centre		University/college
	Swimming baths		Vantage point
	Hospital		Bank machine
	Ski resort		Winery
	School		Volvo dealer
	Yacht harbour/Marina		Toll booth
	City hall		Zoo
	Major companies		
	Safety camera		
	Theatre/opera		



Frequently asked questions.....	76
EULA - License agreement.....	78
Copyright.....	80

06

QUESTIONS AND ANSWERS



Frequently asked questions

The position of the car on the map is wrong

The GPS system shows the position of the car with an accuracy of about 20 metres.

There is a greater chance of error when driving on roads lying parallel to another road, on winding roads, on roads on several levels and after driving a long distance without making any distinctive turns.

High mountains, buildings, tunnels, viaducts, over/underpasses etc. also have a negative affect on the reception of GPS signals, which means that accuracy in calculating the position of the car may decrease.

The system does not always calculate the fastest/shortest route

When calculating a route, distance, width of road, type of road, number of right or left turns, roundabouts etc. are all taken into account in order to produce the best theoretical route. A more efficient selection of route may be possible based on experience and knowledge of the area.

The system uses toll roads, motorways and ferries even though I chose to avoid them

For technical reasons, the system can only use larger roads when calculating a route extending over a long distance.

If **No** is selected for toll roads and motorways, then they are avoided to the greatest possible extent and are only used if there is no other reasonable alternative available.

The position of the car on the map is incorrect after transportation

If the car is transported, for example by ferry or train, or in such a way as to impede the reception of GPS signals, it can take up to 5 minutes before the position of the car is correctly calculated.

The position of the car on the map is incorrect after the car battery has been disconnected

If power has been cut from the GPS antenna, it can take more than 5 minutes for the GPS signals to be received correctly and the position of the car to be calculated.

The car symbol on screen behaves erratically after a tyre change

In addition to the GPS receiver, the car's speed sensor and a gyro assist in calculating the current position and direction of travel of the car. After fitting the spare wheel or changing from summer to winter tyres the system needs to "learn" the size of the new wheels.

To achieve the optimum functionality of the system it may therefore be necessary to drive

a number of kilometres including several significant turns.

The map image does not correspond with the real situation

Factors such as the constant expansion and rebuilding of the road network, new traffic regulations constantly being introduced etc. mean that the digital map database is not always complete. The information stored in the maps is constantly being developed and updated. Your Volvo Dealer can provide further information.

See also www.volvocars.com/navi for further information on maps etc.

The scale of the map sometimes changes

There is no detailed map information in certain areas. The system then automatically changes the degree of magnification.

The expected menu option is missing

Check the settings that have been made. Select **Return to basic settings** for the function in order to restore the original settings.

The system shows the route I am already on

The system cannot find a good alternative to the current route when I selected **Calculate new** or **Diversions**.

**Frequently asked questions****The car symbol on screen jumps forwards or spins**

The system may need a few seconds to sense the position and movement of the car before driving off. Switch off both the system and the engine. Start again, but remain stationary for a while before starting to drive.

I'm going to make a long journey but do not want to specify a special destination to the cities I am thinking of travelling through. How do I most easily create an itinerary?

Specify the destination directly on the map using the hairline cross. The system automatically guides you to the final destination even though you are driving beside the intermediate destinations.

Why do I not always receive traffic messages?

The function is not accessible, fully developed or not available in all markets. Check also that the correct settings are made under **Route options**.

My map information is not up-to-date

Contact your Volvo Dealer regarding the updating of map data.

See also www.volvocars.com/navi



EULA - License agreement

Notice to the user

PLEASE READ THIS END USER LICENSE AGREEMENT CAREFULLY BEFORE USING THE NAVTEQ DATABASE.

THIS IS A LICENSE AGREEMENT - AND NOT AN AGREEMENT FOR SALE - BETWEEN YOU AND NAVTEQ EUROPE B.V. FOR YOUR COPY OF THE NAVTEQ NAVIGABLE MAP DATABASE, INCLUDING ASSOCIATED COMPUTER SOFTWARE, MEDIA AND EXPLANATORY PRINTED DOCUMENTATION PUBLISHED BY NAVTEQ (JOINTLY "THE DATABASE"). BY USING THE DATABASE, YOU ACCEPT AND AGREE TO ALL TERMS AND CONDITIONS OF THIS END USER LICENSE AGREEMENT ("AGREEMENT"). IF YOU DO NOT AGREE TO THE TERMS OF THIS AGREEMENT, PROMPTLY RETURN THE DATABASE, ALONG WITH ALL OTHER ACCOMPANYING ITEMS, TO YOUR SUPPLIER FOR A REFUND.

OWNERSHIP

The Database and the copyrights and intellectual property or neighbouring rights therein are owned by NAVTEQ or its licensors. Ownership of the media on which the Database is contained is retained by NAVTEQ and/or your supplier until after you have paid in full any amounts due to NAVTEQ and/or your supplier pursuant to this Agreement or similar agreement(s) under which goods are provided to you.

LICENSE GRANT

NAVTEQ grants you a non-exclusive license to use the Database for your personal use or, if applicable, for use in your business' internal operations. This license does not include the right to grant sub-licenses.

LIMITATIONS ON USE

The Database is restricted for use in the specific system for which it was created. Except to the extent explicitly permitted by mandatory laws (e.g. national laws based on the European Software Directive (91/250) and the Database Directive (96/9)), you may not extract or reutilise substantial parts of the contents of the Database nor reproduce, copy, modify, adapt, translate, disassemble, decompile, reverse engineer any portion of the Database. If you wish to obtain interoperability information as meant in (the national laws based on) the European Software Directive, you shall grant NAVTEQ reasonable opportunity to provide said information on reasonable terms, including costs, to be determined by NAVTEQ.

TRANSFER OF LICENSE

You may not transfer the Database to third parties, except when installed in the system for which it was created or when you do not retain any copy of the Database, and provided that the transferee agrees to all terms and conditions of this Agreement and confirms this in

writing to NAVTEQ. Multi-disc sets may only be transferred or sold as a complete set as provided by NAVTEQ and not as subset thereof.

LIMITED WARRANTY

NAVTEQ warrants that, subject to the warnings set out below, for a period of 12 months after acquisition of your copy of the Database, it will perform substantially in accordance with NAVTEQ's Criteria for Accuracy and Completeness existing on the date you acquired the Database; these criteria are available from NAVTEQ at your request. If the Database does not perform in accordance with this limited warranty, NAVTEQ will use reasonable efforts to repair or replace your non-conforming copy of the Database. If these efforts do not lead to performance of the Database in accordance with the warranties set out herein, you will have the option to either receive a reasonable refund of the price you paid for the Database or to rescind this Agreement. This shall be NAVTEQ's entire liability and your sole remedy against NAVTEQ. Except as expressly provided in this section, NAVTEQ does not warrant nor make any representations regarding the use of results of the use of the Database in terms of its correctness, accuracy, reliability, or otherwise. NAVTEQ does not warrant that the Database is or will be error free. No oral or written information or advice provided by NAVTEQ, your supplier or any other person shall

**EULA - License agreement**

create a warranty or in any way increase the scope of the limited warranty described above. The limited warranty set forth in this Agreement does not affect or prejudice any statutory legal rights that you may have under the legal warranty against hidden defects.

If you did not acquire the Database from NAVTEQ directly, you may have statutory rights against the person from whom you have acquired the Database in addition to the rights granted by NAVTEQ hereunder according to the law of your jurisdiction. The above warranty of NAVTEQ shall not affect such statutory rights and you may assert such rights in addition to the warranty rights granted herein.

LIMITATION OF LIABILITY

The price of the Database does not include any consideration for assumption of risk of consequential, indirect or unlimited direct damages which may arise in connection with your use of the Database. Accordingly, in no event shall NAVTEQ be liable for any consequential or indirect damages, including without limitation, loss of revenue, data, or use, incurred by you or any third party arising out of your use of the Database, whether in an action in contract or tort or based on a warranty, even if NAVTEQ has been advised of the possibility of such damages. In any event NAVTEQ's liability for

direct damages is limited to the price of your copy of the Database.

THE LIMITED WARRANTY AND LIMITATION OF LIABILITY, SET FORTH IN THIS AGREEMENT, DO NOT AFFECT OR PREJUDICE YOUR STATUTORY RIGHTS WHERE YOU HAVE ACQUIRED THE DATABASE OTHERWISE THAN IN THE COURSE OF A BUSINESS.

WARNINGS

The database may include incorrect or incomplete information due to changes over time, changes of circumstances, the quality of the sources used and the process used for collection of extensive geographical data. All of these situations may lead to erroneous results. The Database does not include or reflect information on - inter alia - neighbourhood safety; law enforcement; emergency assistance; construction work; road or lane closures; vehicle or speed restrictions; road slope or grade; bridge height, weight or other limits; road or traffic conditions; special events; traffic congestion; or travel time.

GOVERNING LAW

This Agreement shall be governed by the laws of the jurisdiction, in which you reside at the date of acquisition of the Database. Should you at that moment reside outside the European Union or Switzerland, the law of the jurisdiction

within the European Union or Switzerland where you acquired the Database shall apply. In all other cases, or if the jurisdiction where you acquired the Database cannot be defined, the laws of the Netherlands shall apply. The courts competent at your place of residence at the time you acquired the Database shall have jurisdiction over any dispute arising out of, or relating to this Agreement, without prejudice to NAVTEQ's right to bring claims at your then current place of residence.



Copyright

Austria

© Bundesamt für Eich- und Vermessungswesen.

France

Source Géoroute® IGN France & BD Carto® IGN France.

Germany

Die Grundlagendaten wurden mit Genehmigung der zuständigen Behörden entnommen.

Great Britain

© Based upon Crown Copyright material.

Greece

Copyright Geomatics Ltd.

Hungary

Copyright © 2003; Top-Map Ltd.

Italy

La Banca Dati Italiana è stata prodotta usando quale riferimento anche cartografia numerica ed al tratto prodotta e fornita dalla Regione Toscana.

Norway

Copyright © 2000; Norwegian Mapping Authority.

Poland

© EuroGeographics.

Portugal

Source: IgeoE - Portugal.

Spain

Información geográfica propiedad del CNIG.

Sweden

Based upon electronic data © National Land Survey Sweden.

Switzerland

Topografische Grundlage: © Bundesamt für Landestopographie.

© 2005-2009 NAVTEQ All rights reserved.



NOTE

Australia is not covered by this agreement; see special information.



1, 2, 3 ...

2D or 3D..... 35, 56

A

About

information on the map disc..... 58

Acoustic signal

camera..... 57

Stored location..... 47

Address

enter..... 31, 44

Arrow keys..... 20

Audible signal

road camera..... 57

stored location..... 47

Avoid

ferries..... 54

motorways..... 54

specified areas..... 54

time-restr. roads..... 54

toll roads..... 54

traffic problems..... 54

B

Basic settings..... 9

Battery

deactivation..... 76

remote control..... 20

C

Camera

acoustic signal..... 57

camera (Audible signal)..... 57

Change between settings..... 28

Changes in the manual..... 8

Compass..... 23, 56

Component location and functions C30.... 14

Component location and functions C70.... 16

Component location and functions XC90.. 18

Controls..... 20

Coordinates

search..... 48

Copyright..... 80

Current position..... 52

D

Delete destination..... 34

Delete in itinerary..... 50

Demo..... 10, 59

Destination..... 49

last 20..... 33, 47

set..... 31, 44

Detour

quick menu..... 39

Distance unit..... 35

ETA..... 56

Do not disturb - symbol..... 20

Drop-down menu

advanced mode..... 40

simple mode..... 28

DVD disc

care..... 24

changing..... 24

E

Elevation angle in 3D..... 56

ENTER..... 20

Enter an itinerary..... 49

F

Facilities	
quick menu.....	39
Symbols.....	71
Facility as destination.....	32, 45
Factory settings.....	9

G

GPS information.....	58
Guidance	
start.....	32, 45
Guiding options.....	56
Guiding voice.....	35
Guiding volume.....	35

H

Hill and level differences.....	70
---------------------------------	----

I

IR receiver and remote control.....	20
Itinerary.....	49
next destination.....	51

K

Keypad	
location.....	20

L

Landmarks.....	70
Language.....	35, 57
Last 20 destinations.....	33, 47
Latitude and longitude.....	48
Level differences	
mark on map.....	70
License agreement.....	78
Longitude and latitude.....	48

M

Main menu Advanced.....	38
Main menu Simple.....	28
Main unit	
contents.....	24
Main unit C30	
location.....	15
Main unit C70	
location.....	17
Main unit XC90	
location.....	19
Map.....	38
2D or 3D.....	56
colour on screen.....	35, 57
direction.....	56
point on.....	33
show/hide.....	56
Map colour.....	35
Map disc	
care.....	24
changing.....	24
Map image.....	23
Map mode.....	9
Map options.....	55

Map scale/Current route in quick menu	28, 38
Map scrolling	
advanced mode.....	40
simple mode.....	28
Map view.....	35
Menu options.....	8, 42
Menu tree	
advanced.....	42
simple.....	30

N

Navigation button.....	20
Next destination in itinerary.....	51

O

On/Off.....	9
-------------	---

P

Point on map.....	33, 47
Post code	
search.....	45

Q

Quick menu.....	38
-----------------	----

R

REAR.....	20
Remote control and IR receiver.....	20
Return to default settings.....	55, 58
Return trip.....	47
Road number.....	70
Route.....	38
Route options.....	54

S

Safety camera.....	57
Save a location.....	50
Scale/current route in quick menu.....	28, 38
Screensaver.....	57
Screen settings	
colour of map.....	35
Language.....	35
Scroll menu.....	40
Search	
general.....	21
post code.....	45
via coordinates.....	48
via point on map.....	47
Search paths described in the manual.....	8
Set destination.....	31, 44
Set for surveill.....	39, 40
Settings	
route.....	54
Show destination.....	34
Simple user settings.....	28
Simulation.....	59
Speakers.....	15, 17, 19

Start guidance.....	32, 45
Store a location.....	50
Stored location	
Acoustic signal.....	47
Stored locations.....	46
Symbols	
facilities.....	71
System options.....	57
System settings.....	9

T

Toll roads.....	57
Traffic information.....	28
quick menu.....	39
Transport of car.....	76
TV screen	
care.....	24

U

User settings	
change between.....	10, 35

V

Voice guidance.....	23
quick menu.....	28, 38

W

Waypoint.....	49
---------------	----

