



VOLVO V50

OWNER'S MANUAL



WEB EDITION

DEAR VOLVO OWNER

THANK YOU FOR CHOOSING VOLVO

We hope that you will enjoy many years of driving pleasure in your Volvo. The car has been designed for the safety and comfort of you and your passengers. Volvo is one of the safest cars in the world. Your Volvo has also been designed to satisfy all current safety and environmental requirements.

In order to increase your enjoyment of the car, we recommend that you familiarise yourself with the equipment, instructions and maintenance information contained in this Owner's Manual.





00 Introduction

Introduction	6
Volvo Cars and the environment	7



01 Safety

Seatbelts	12
Airbag system	15
Airbags (SRS)	16
Activating/deactivating the airbag (SRS)	18
Side airbags (SIPS bags)	20
Inflatable Curtain (IC)	22
WHIPS	23
When the systems deploy	25
Crash mode	26
Child safety	27

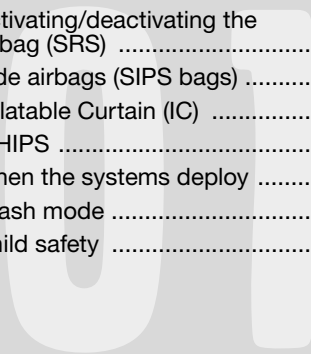

02 Instruments and controls

Overview, left-hand drive cars	34
Overview, right-hand drive cars	36
Driver's door control panel	38
Combined instrument panel	39
Indicator and warning symbols	40
Information display	44
Electrical socket	45
Lighting panel	46
Left-hand stalk switch	49
Right-hand stalk switch	51
Cruise control (option)	53
Steering wheel keypad (option)	54
Steering wheel adjustment, hazard warning flashers	55
Parking brake	56
Power windows	57
Rearview and door mirrors	59
Power sunroof (option)	63
Personal preferences	65

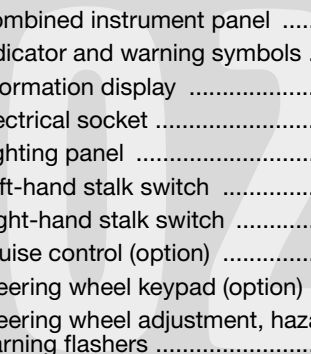



03 Climate control

General information on climate control	70
Manual climate control, AC	72
Electronic climate control, ECC (option)	75
Air distribution	78
Fuel-driven heater (option)	79

03



04 Interior

Front seats	84
Interior lighting	86
Storage spaces in the passenger compartment	88
Rear seat	92
Cargo area	94

04



05 Locks and alarm

Remote control with key blade	100
Active locks	103
Keyless drive (option)	104
Battery in remote control	107
Locking and unlocking	108
Child safety locks	111
Alarm (option)	112

05



06 Starting and driving

General	118
Refuelling	120
Starting the engine	121
Starting the engine – Flexifuel	123
Keyless drive (option)	124
Manual gearbox	125
Automatic gearbox	127
All-wheel drive	130
Brake system	131
Stability and traction control system	133
Parking assistance (option)	135
BLIS – Blind Spot Information System (option)	138
Towing and recovery	142
Start assistance	144
Driving with a trailer	145
Towing equipment	147
Detachable towbar	149
Loading	154
Adjusting headlamp pattern	155



07 Wheels and tyres

General	158
Tyre pressure	162
Warning triangle and spare wheel	164
Changing wheels	165
Emergency puncture repair	167



08 Car care

Cleaning	174
Touching up paintwork	177
Rustproofing	178

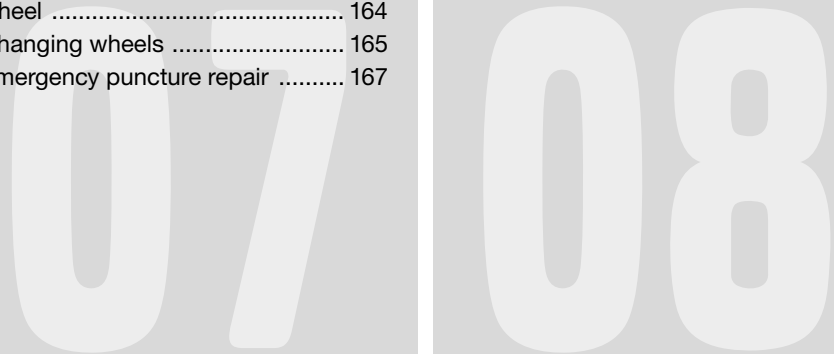



09 Maintenance and service

Volvo service	182
Self-maintenance	183
Bonnet and engine compartment	184
Diesel	185
Oils and fluids	186
Wiper blades	191
Battery	192
Replacing bulbs	194
Fuses	201



10 Infotainment system

General	210
Audio functions	211
Radio functions	214
CD functions	218
Menu structure – audio system ...	220
Phone functions (option)	221
Menu structure – phone	228



11 Specifications

Type designation	234
Dimensions and weights	235
Engine specifications	237
Engine oil	239
Fluids and lubricants	243
Fuel	245
Catalytic converter	249
Electrical system	250
Type approval	252



Introduction

Owner's Manual

A good way of getting to know your new car is to read the Owner's Manual, ideally before your first journey. This will give you the opportunity to familiarise yourself with new functions, to see how best to handle the car in different situations, and to make the best use of all the car's features. Please pay attention to the safety instructions contained in the manual:



WARNING

"Warning!" texts indicate where there is a risk of personal injury in the event of the instructions not being followed.



IMPORTANT

"Important!" texts indicate a risk of damage to the car in the event of the instructions not being followed.

The equipment described in the owner's manual is not present in all models. In addition to standard equipment, this manual also describes options (factory fitted equipment) and certain accessories (extra equipment).



NOTE

Volvo cars are adapted for the varying requirements of different markets, as well as for national or local legal requirements and regulations. If you are uncertain over what is standard, an option or an accessory then contact your Volvo dealer.

The specifications, design features and illustrations in this Owner's Manual are not binding. We reserve the right to make modifications without prior notice.

© Volvo Car Corporation

Volvo Cars and the environment**Volvo Cars' environmental philosophy**

Environmental care, safety and quality are the three core values which influence all operations of the Volvo Car Corporation. We also believe that our customers share our consideration for the environment.

Your Volvo complies with strict international environmental standards and is also manufactured in one of the cleanest and most resource-efficient plants in the world.

Volvo Car Corporation has global ISO certification, which includes the environmental standard (ISO 14001) covering factories, central functions, as well as several of our

other units. We also set requirements for our partners so that they work systematically with environmental issues.

EPI (Environmental Product Information) is supplied for all Volvo models. Here you can see how the environment is affected during the entire lifecycle of the car.

Read more at www.volvocars.com/EPI.

Fuel consumption

Volvo cars have competitive fuel consumption in each of their respective classes. Lower fuel consumption generally results in

lower emission of the greenhouse gas, carbon dioxide.

It is possible for the driver to influence fuel consumption. For more information read under the heading Reducing environmental impact on page 8.

Volvo Cars and the environment

Efficient emission control

Your Volvo is manufactured following the concept **Clean inside and out** – a concept that encompasses a clean interior environment as well as highly efficient emission control. In many cases the exhaust emissions are well below the applicable standards.

Clean air in the passenger compartment

A passenger compartment filter prevents dust and pollen from entering the passenger compartment via the air intake.

A sophisticated air quality system, IAQS¹ (Interior Air Quality System) ensures that the incoming air is cleaner than the air in the traffic outside.

The system consists of an electronic sensor and a carbon filter. The incoming air is monitored continuously and if there is an increase in the level of certain unhealthy gases such as carbon monoxide then the air intake is closed. Such a situation may arise in heavy traffic, queues and tunnels for example.

The entry of nitrous oxides, ground-level ozone and hydrocarbons is prevented by the carbon filter.

¹ Option

Textile standard

The interior of a Volvo is designed to be pleasant and comfortable, even for people with contact allergies and for asthma sufferers. All of our upholstery and interior textiles are tested with respect to certain unhealthy substances and allergens as well as emissions. This means that all textiles fulfil the requirements in the Öko-Tex 100 standard², a major advance towards a healthier passenger compartment environment.

Öko-Tex certification covers seatbelts, carpets and fabrics for example. The leather in the upholstery undergoes chromium-free tanning with natural plant substances and fulfils the certification requirements.

Volvo workshops and the environment

Regular maintenance creates the conditions for a long service life and low fuel consumption for your car, and in this way you contribute to a cleaner environment. When Volvo's workshops are entrusted with the service and maintenance of your car it becomes part of our system. We make clear demands regarding the way in which our workshops are designed in order to prevent spills and discharges into the environment. Our workshop staff have the knowledge and the tools required to guarantee good environmental care.

² More information on www.oekotex.com

Reducing environmental impact

You can easily help reduce environmental impact, for example, by driving economically, by purchasing eco-labelled car care products and by servicing and maintaining the car in accordance with the instructions in the owner's manual.

The following hints will help you to do your bit for the environment (for further advice on how you can reduce environmental impact and drive economically, see page 118).

- Decrease fuel consumption by choosing ECO tyre pressure, see page 162.
- A roof load and ski box increase wind resistance, leading to significantly higher fuel consumption. Remove them immediately after use.
- Remove unnecessary items from the car - the greater the load the higher the fuel consumption.
- Is your car equipped with an engine block heater? If so, use it for a few hours before starting from cold to reduce fuel consumption and exhaust emissions.
- Drive gently and avoid braking too hard.

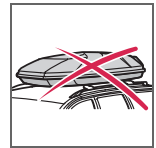

Volvo Cars and the environment

- Drive in the highest gear possible. Low engine speeds result in lower fuel consumption.



- Use engine braking to slow down.

- Avoid idling. Take consideration of local regulations. Switch off the engine in longer stationary traffic.

- Always dispose of environmentally hazardous waste, such as batteries and oils, in an environmentally responsible manner. If uncertain, consult an authorised Volvo workshop for advice.

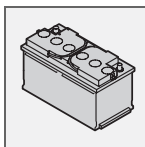

- Service your car regularly.
- High speed increases consumption considerably due to increased wind resistance. A doubling of speed increases wind resistance four times.

These hints will help you to reduce your fuel consumption without increasing your travel time or lessening the enjoyment of driving. Apart from being kind to your car, you'll be saving money - and the Earth's resources.

Seatbelts	12
Airbag system	15
Airbags (SRS)	16
Activating/deactivating the airbag (SRS)	18
Side airbags (SIPS bags)	20
Inflatable Curtain (IC)	22
WHIPS	23
When the systems deploy	25
Crash mode	26
Child safety	27

SAFETY



01



Seatbelts

Always use a seatbelt

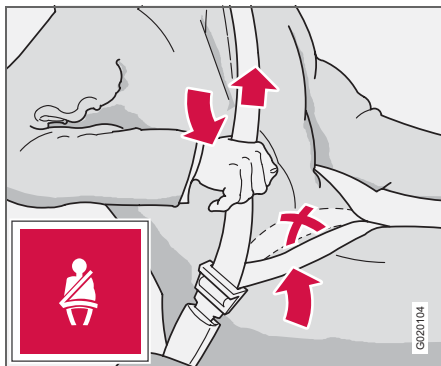

Tensioning the hip strap. The belt must be positioned low down.

Heavy braking can have serious consequences if the seatbelts are not used, so make sure that all passengers use their seatbelts. It is important that the seatbelt lies against the body so it can provide maximum protection. Do not lean the backrest too far back. The seatbelt is designed to protect in a normal seating position.

Putting on a seatbelt:

- Pull the seatbelt out slowly and secure it by pressing the buckle into the lock. A loud "click" indicates that the seatbelt has locked.

Releasing the seatbelt

- Press the red lock button and then let the seatbelt retract. If the seatbelt does not retract fully, feed the seatbelt in by hand so that it does not hang loose.

The seatbelt locks and cannot be withdrawn:

- if it is pulled out too quickly.
- during braking and acceleration.
- if the car leans heavily.

Keep in mind the following:

- do not use clips or anything else that can prevent the seatbelt from fitting properly
- ensure that the seatbelt is not twisted or caught on anything
- the hip strap must be positioned low down (not over the abdomen)
- tension the hip strap over the lap by pulling the diagonal shoulder belt as illustrated.

WARNING

The seatbelts and airbags interact. If a seatbelt is not used or is used incorrectly, this may diminish the protection provided by the airbag in the event of a collision.

WARNING

Each seatbelt is designed for only one person.

WARNING

Never modify or repair the seatbelt yourself. Contact an authorised Volvo workshop. If the seatbelt has been subjected to a major load, such as in a collision, the entire seatbelt must be replaced. Some of the seatbelt's protective properties may have been lost even if the seatbelt does not appear damaged. The seatbelt must also be replaced if it shows signs of wear or damage. The new seatbelt must be type-approved and designed for installation at the same location as the replaced seatbelt.



Seatbelts

01

Seatbelts and pregnancy



The seatbelt should always be worn during pregnancy. But it is crucial that it be worn in the correct way. The diagonal section of the seatbelt should wrap over the shoulder then be routed between the breasts and to the side of the abdomen. The lap section of the seatbelt should lay flat over the thighs and as low as possible under the abdomen. It must never be allowed to ride upward. Remove all slack from the seatbelt and ensure that it fits close to the body. In addition, check that there are no twists in the seatbelt.

As a pregnancy progresses, pregnant drivers should adjust their seats and steering wheel such that they can easily maintain control of

the vehicle as they drive (which means that they must be able to easily operate the foot pedals and steering wheel). They should strive to position the seat with as large a distance as possible between their abdomen and the steering wheel.

Seatbelt reminder



Unbelted occupants will be reminded to fasten their seatbelts through an audio and visual reminder. The audio reminder is speed dependent, and in some cases time dependent. The visual reminder is located in the roof console and the combined instrument panel.

Child seats are not covered by the seatbelt reminder system.

Rear seat

The seatbelt reminder in the rear seat has two subfunctions:

- To provide information on which seatbelts are being used in the rear seat. The information is shown when the seatbelts are



Seatbelts

being used or when the rear doors are opened. This is shown on the information display. The message is automatically cleared after approx. 30 seconds or it can be acknowledged manually by pressing the **READ** button.

- To provide a warning if one of the rear seatbelts is unfastened during a journey. This warning takes the form of a message on the information display along with the audio/visual signal. The warning ceases when the seatbelt is re-fastened or when manually acknowledged by pressing the **READ** button.

The message on the information display showing which seatbelts are in use is always available. Press the **READ** button to see stored messages.

Certain markets

An unbelted driver will be reminded to fasten his or her seatbelt through an audio and visual reminder. At low speed, the audio reminder will sound for the first six seconds.

Seatbelt tensioner

All the seatbelts are equipped with seatbelt tensioners. A mechanism in the seatbelt tensioner tightens the seatbelt in the event of a sufficiently violent collision. The seatbelt then provides more effective restraint for occupants.



Warning symbol on the combined instrument panel

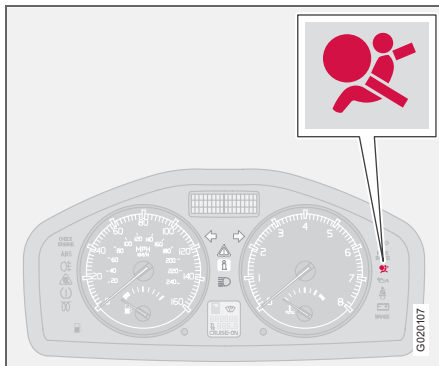

The airbag system¹ is continually monitored by the system control module. The warning symbol in the combined instrument panel illuminates when the ignition key is turned to position **I**, **II** or **III**. The symbol goes out after approx. 6 seconds provided the airbag system¹ is working correctly.



As well as the warning symbol, a message may appear on the display in appropriate cases. If the warning symbol malfunctions, the warning triangle illuminates and the message **SRS AIRBAG SERVICE REQUIRED** or **SRS AIRBAG SERVICE URGENT** appears on the display. Contact an authorised Volvo workshop urgently.



WARNING

If the warning symbol for the airbag system remains on or illuminates while driving, it means that the airbag system is not functioning fully. The symbol indicates a fault in the seatbelt buckle, SIPS, SRS system or IC system. Contact an authorised Volvo workshop urgently.

¹ Includes SRS and seatbelt tensioner, SIPS and IC.



Airbags (SRS)

Airbag (SRS) on the driver's side

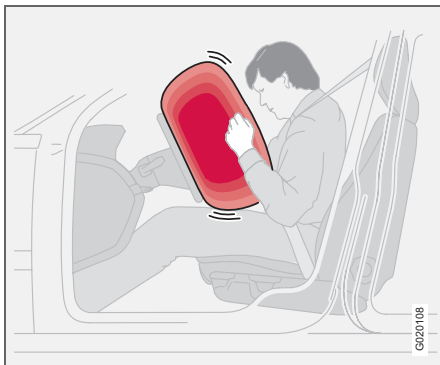

The car has an SRS airbag (Supplemental Restraint System) in the steering wheel to supplement the protection afforded by the seatbelt on the driver's side. This airbag is folded up into the centre of the steering wheel. The steering wheel is marked **SRS AIRBAG**.

WARNING

The seatbelts and airbags interact. If a seatbelt is not used or is used incorrectly, this may diminish the protection provided by the airbag in the event of a collision.

Passenger airbag (SRS)

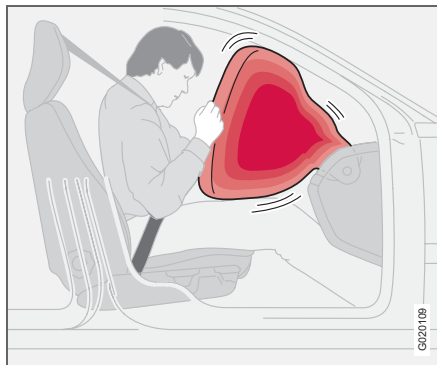

The car has an airbag¹ to supplement the protection afforded by the seatbelt on the passenger side. This airbag is folded up into a compartment above the glovebox, and its cover panel is marked **SRS AIRBAG**.

WARNING

To minimise the risk of injury if the airbag deploys, passengers must sit as upright as possible with their feet on the floor and backs against the backrest. Seatbelts must be secured.

¹ Not all cars have a passenger airbag (SRS). This can be unselected when the car is ordered.

WARNING

Never place a child in a child seat or on a booster cushion in the front seat if the airbag (SRS) is activated.¹

Never allow a child to stand or sit in front of the front passenger seat. No one shorter than 140 cm should sit in the front passenger seat if the airbag (SRS) is activated.

Failure to follow the advice given above can endanger the life of the child.

¹ For information on activated/deactivated airbag (SRS) see page 18.



Airbags (SRS)

Airbag system

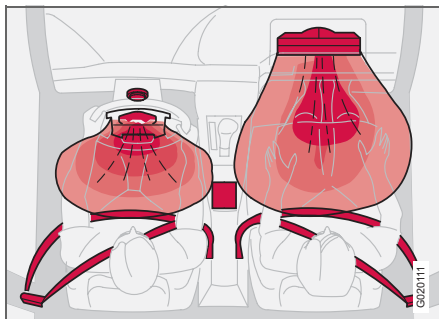

SRS system, left-hand drive

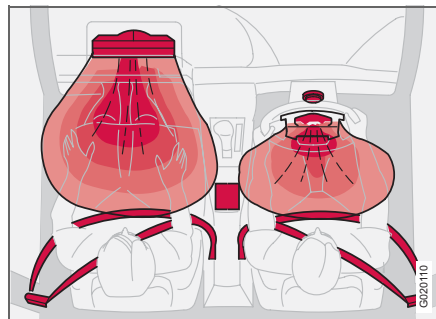

SRS system, right-hand drive

The system consists of airbags and sensors. A sufficiently violent collision trips the sensors and the airbag(s) are inflated with hot gas. To cushion the impact, the airbag deflates when compressed. When this occurs, smoke escapes into the car. This is completely normal. The entire process, including inflation and deflation of the airbag, takes place within tenths of a second.

**WARNING**

Repairs must only be performed by an authorised Volvo workshop. Any interference in the airbag system could cause malfunction and result in serious injury.

**NOTE**

The sensors react differently depending on the course of the collision and whether or not the seatbelts on the driver's side and passenger side are used.

It is therefore possible that only one (or none) of the airbags may inflate in a collision. The airbag system senses the force of the collision on the car and adapts accordingly so that one or more airbags is deployed.

The capacities of the airbags are also adapted to the collision force to which they are subjected.

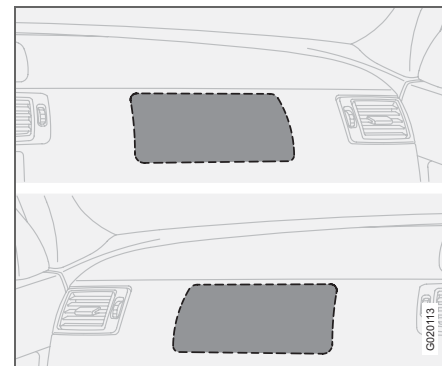

Location of the passenger airbag in left-hand drive and right-hand drive cars

**WARNING**

Do not put objects in front of or above the instrument panel where the passenger airbag is located.



Activating/deactivating the airbag (SRS)

PACOS¹ (option)



Indicator showing that the passenger airbag (SRS) is deactivated.

The airbag (SRS) for the front passenger seat can be deactivated if the car is equipped with a PACOS switch, see page 19.

Messages

A text message and a symbol in the roof panel indicates that the airbag (SRS) for the front passenger seat is deactivated (see illustration above).



Indicator showing that the passenger airbag (SRS) is activated.

NOTE

When the remote control key is inserted into ignition position II or III the warning symbol for the airbag is shown in the combined instrument panel for approx. 6 seconds (see page 15).

Following which, the indicator in the roof console is illuminated showing the correct status for the front passenger seat airbag. For more information on the different ignition positions, see page 122.

A warning symbol in the roof panel indicates that the airbag (SRS) for the front passenger seat is activated (see illustration above).

For information on how switching takes place, see below.

Activating/deactivating

The switch for the passenger airbag (PACOS) is located on the passenger end of the instrument panel and is accessible when the passenger door is open, (see under the heading, Switch – PACOS below). Check that the switch is in the required position. Volvo recommends that the key blade is used to change position.

For information on the key blade, see page 101. (Other items with a shape similar to a key can also be used.)

WARNING

Failure to follow the advice given above can endanger life.

WARNING

If the car is equipped with a front passenger airbag (SRS), but does not have PACOS, the airbag will always be activated.

¹ PACOS (Passenger Airbag Cut Off Switch)



Activating/deactivating the airbag (SRS)

WARNING

Never place a child in a child seat or on a booster cushion in the front seat if the airbag is activated and the symbol in the roof console is illuminated. Failure to follow this advice could endanger the life of the child.

WARNING

Do not allow anyone to sit in the front passenger seat if the text message in the roof panel indicates that the airbag (SRS) is deactivated and the Airbag system warning symbol is displayed in the combined instrument panel. This indicates that there has been a severe malfunction. Visit an authorised Volvo workshop urgently.

Switch – PACOS

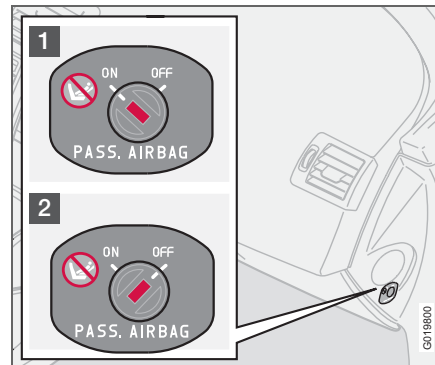

Switch location

- The airbag is activated (1). With the switch in this position, persons taller than 140 cm can sit in the front passenger seat, but never children in a child seat or on a booster cushion.
- The airbag is deactivated (2). With the switch in this position, children in a child seat or on a booster cushion can sit in the front passenger seat, but never anybody taller than 140 cm.

WARNING

Activated airbag (passenger seat):
Never place a child in a child seat or on a booster cushion on the front passenger seat when the airbag is activated. This applies to everyone shorter than 140 cm.

Deactivated airbag (passenger seat):
No one taller than 140 cm should ever sit in the front passenger seat when the airbag is deactivated.

Failure to follow the advice given above can endanger life.



Side airbags (SIPS bags)

Side airbag – SIPS bag



Side airbag locations

A large proportion of the collision force is transferred by the SIPS (Side Impact Protection System) to beams, pillars, the floor, the roof and other structural parts of the body. The side airbags at the driver's and front passenger seats protect the chest area and are an important part of the SIPS. The side airbags are located in the front seat backrests.



WARNING

Repairs must only be performed by an authorised Volvo workshop. Any interference in the SIPS bag system could cause malfunction and result in serious personal injury.



WARNING

Do not put objects in the area between the outside of the seat and the door panel, since this area is required by the side airbag.



WARNING

Only use car seat covers approved by Volvo. Other seat covers may impede the operation of the side airbags.



WARNING

Side airbags are a supplement the seatbelts. Always wear your seatbelt.

Child seats and side airbags

The side airbag does not diminish the protection provided by the car to children seated in a child seat or on a booster cushion.

A child seat or booster cushion can be placed on the front passenger seat provided that the car does not have an activated¹ passenger airbag.

¹ For information on activated/deactivated airbag (SRS) see page 18



Side airbags (SIPS bags)

SIPS bags



Driver's seat, left-hand drive



Front passenger seat, left-hand drive

The SIPS bag system consists of side airbags and sensors. A sufficiently violent collision trips the sensors and the side airbags are inflated. The airbag inflates between the occupant and the door panel and thereby cushions the initial impact. The airbag deflates when compressed by the collision. The side airbag is normally only deployed on the side of the collision.

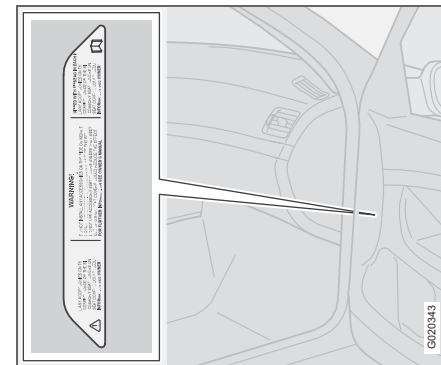

Location of airbag decal in door opening on front passenger side



Inflatable Curtain (IC)

Properties

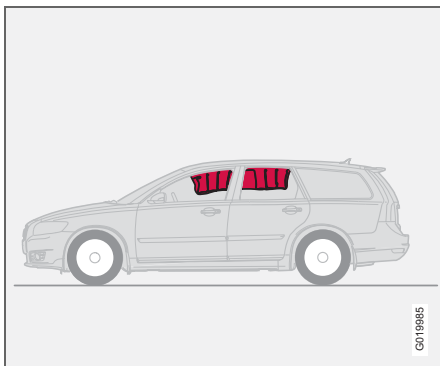

The inflatable curtain IC (Inflatable Curtain) is a supplement to the SIPS and the airbags. It is fitted in the headlining along both sides of the roof and protects all of the vehicle's outer seats. A sufficiently violent collision trips the sensors and the inflatable curtain is inflated. The inflatable curtain helps to prevent the driver and passengers from striking their heads on the inside of the car during a collision.



WARNING

Never hang or attach heavy items onto the handles in the roof. The hook is only designed for light clothing (not for solid objects such as umbrellas for example).

Do not screw or fit anything to the headlining, door pillars or side panels. This could compromise the intended protection. Only use Volvo genuine parts that are approved for placement in these areas.



WARNING

Do not load the car higher than 50 mm under the top edge of the side windows. Otherwise, the intended protection of the inflatable curtain, which is concealed in the headlining, may be compromised.



WARNING

The inflatable curtain is a supplement to the seatbelts.

Always use a seatbelt.



Protection against whiplash injury – WHIPS

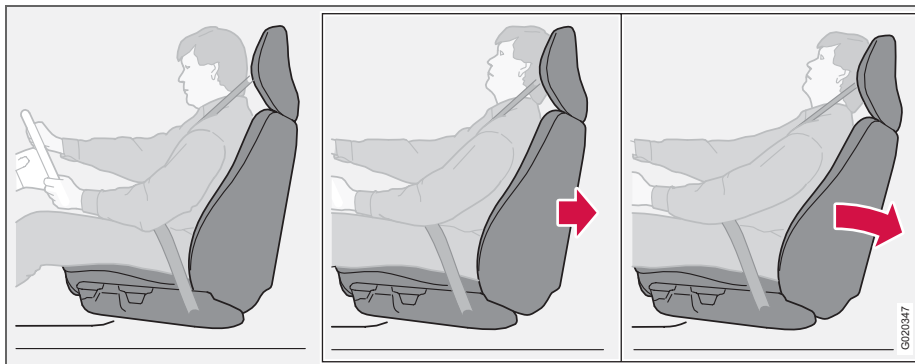

The whiplash protection system (WHIPS) consists of energy absorbing backrests and specially designed head restraints for the front seats. The system is actuated by a rear-end collision, where the angle and speed of the collision, and the nature of the colliding vehicle all have an influence.

WARNING

The WHIPS system is a supplement to the seatbelts. Always wear your seatbelt.

Properties of the seat

When the WHIPS system is deployed, the front seat backrests fall backward to alter the position of the driver and front seat passenger. This diminishes the risk of whiplash injury.

WARNING

Never modify or repair the seat or WHIPS system yourself. Contact an authorised Volvo workshop.

WHIPS system and child seats/booster cushions

The WHIPS system does not diminish the protection provided by the car to children seated in a child seat or on a booster cushion.

Correct seating position

For the best possible protection, the driver and front seat passenger should sit in the centre of the seat with as little space as possible between the head and the head restraint.



WHIPS

Do not obstruct the WHIPS system

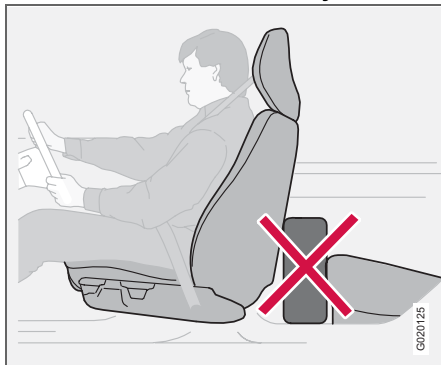

WARNING

Do not squeeze rigid objects between the rear seat cushion and the front seat backrest. Make sure you do not obstruct the function of the WHIPS system.

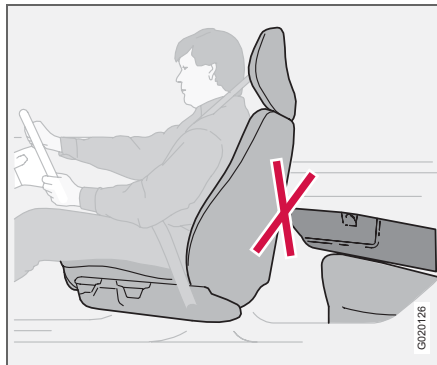

WARNING

If a rear seat backrest is folded down, the corresponding front seat must be moved forward so that it does not touch the folded backrest.

WARNING

If a seat has been subjected to extreme forces, such as due to a rear-end collision, the WHIPS system must be checked by an authorised Volvo workshop.

Part of the WHIPS system's protective capacity may have been lost even if the seat appears to be undamaged.

Contact an authorised Volvo workshop to have the system checked after even a minor rear-end collision.



When the systems deploy

System	Triggered
Seatbelt tensioner, front seat	In a frontal collision and/or side-impact accident and/or rear-end collision.
Seatbelt tensioner, outside rear seat	In a frontal collision
Airbags (SRS)	In a frontal collision ¹
Side airbags (SIPS)	In a side-impact accident ¹
Inflatable Curtain IC	In a side-impact accident ¹
Whiplash protection WHIPS	In a rear-end collision

¹The bodywork of the car could be greatly deformed in a collision without airbag deployment. A number of factors such as the rigidity and weight of the object hit, the speed of the car, the angle of the collision etc. affects how the different safety systems of the car are activated.

If the airbags have been deployed, the following is recommended:

- Have the car transported to an authorised Volvo workshop. Do not drive with deployed airbags.
- Let an authorised Volvo workshop replace components in the car's safety system.
- Always contact a doctor.

**NOTE**

The SRS, SIPS, IC and belt tensioner systems are deployed only once during a collision.

**WARNING**

The airbag system control module is located in the centre console. If the centre console is drenched with water or other liquid, disconnect the battery cables. Do not attempt to start the car since the airbags may deploy. Have the car transported to an authorised Volvo workshop.

**WARNING**

Never drive with deployed airbags. They can make steering difficult. Other safety systems may also be damaged. The smoke and dust created when the airbags are deployed can cause skin and eye irritation after intensive exposure. In case of irritation, wash with cold water. The rapid deployment sequence and airbag fabric may cause friction and skin burns.



Crash mode

Driving after a collision

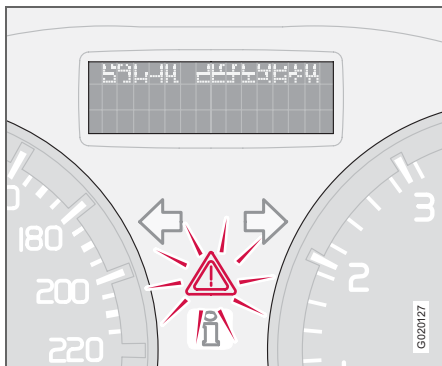

If the car is involved in a collision, the text **CRASH MODE - SEE MANUAL** may appear on the information display. This means that the car has reduced functionality. Crash mode is a protective state that is enforced when the collision may have damaged the car's vital functions, such as the fuel lines, sensors for one of the safety systems, or the brake system.

Attempting to start the car

First, check that no fuel is leaking from the car. There should be no smell of fuel.

If everything seems normal and you have checked for indications of fuel leakage, you may attempt to start the car.

Firstly, remove the ignition key and then reinsert it. The car's electronics will then try to reset themselves to normal mode. Then try to start the car. If **CRASH MODE** is still shown in the display then the car must not be driven or towed. Even if the car appears to be driveable, hidden damage may make the car impossible to control once moving.

Moving the car

If **NORMAL MODE** is shown after **CRASH MODE** has been reset, the car can be moved carefully out of a dangerous position. Do not move the car further than necessary.



WARNING

Never, under any circumstances, attempt to restart the car if it smells of fuel when the **CRASH MODE** message is displayed. Leave the car at once.



WARNING

If the car is in **CRASH MODE** it must not be towed. It must be transported to an authorised Volvo workshop.



WARNING

Never attempt to repair your car or reset the electronics yourself if the car has been in crash mode. This could result in personal injury or the car not functioning as normal. Always allow an authorised Volvo workshop to check and restore the car to **NORMAL MODE** after **CRASH MODE** has been displayed.

**Child safety****Children should sit comfortably and safely**

The position of a child in the car and the choice of equipment is dictated by the child's weight and size. For more information see page 29.

NOTE

Regulations regarding the placement of children in cars vary from country to country. Check what laws apply.

Children of all ages and sizes must always sit correctly secured in the car. Never allow a child to sit on the knee of a passenger.

Volvo's own child safety equipment is designed for your car. Use Volvo genuine equipment to best ensure that the mounting points and attachments are correctly positioned and are sufficiently strong.

NOTE

If problems arise when fitting child safety products, contact the manufacturer for clearer instructions.

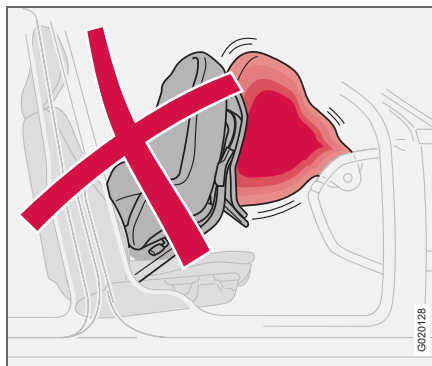
Child seats

Child seats and airbags are not compatible.

Volvo has child safety products that are designed for and tested by Volvo.

NOTE

When using child safety products it is important to read the installation instructions included with the product.

Do not attach the straps for the child seat to the horizontal adjustment bar, springs, rails or beams under the seat. Sharp edges can damage the straps.

Allow the back of the child seat to rest against the dashboard. This applies to cars

without a passenger airbag or where the airbag is deactivated.

Location of child seats

You may place:

- a child seat or booster cushion on the front passenger seat, provided that the passenger airbag is not activated¹.
- a rear-facing child seat in the rear seat that uses the back of the front seat as support.

Always place a child in the rear seat if the passenger airbag is activated. A child in the front passenger seat could suffer serious injury if the airbag deploys.

WARNING

Never place a child in a child seat or on a booster cushion in the front seat if the airbag (SRS) is activated.

No one shorter than 140 cm should ever sit in the front passenger seat if the airbag (SRS) is activated.

Failure to follow the advice given above can endanger the life of the child.

¹ For information on activated/deactivated airbag (SRS) see page 18.



Child safety

WARNING

Booster cushions/child seats with steel braces or some other design that could rest on the seatbelt buckle's opening button must not be used, as they could cause the seatbelt buckle to open accidentally. Do not allow the upper section of the child seat to rest against the windscreen.

Airbag decal



Decal located on instrument panel end face.



Decal located on instrument panel end face (Australia only).



Child safety

01

Placement of children in the car

Weight/age	Front seat ¹	Outer rear seat	Centre rear seat
Group 0 max. 10 kg (0–9 months) Group 0+ max. 13 kg	Volvo Child seat – rear-facing child seat, secured with the car's seatbelt and straps. Use a protective cushion between the child seat and the dashboard. Type approval: E5 03135	Volvo Child seat – rear-facing child seat, secured with the car's seatbelt, straps and support legs. Type approval: E5 03135	Volvo Child seat – rear-facing child seat, secured with the car's seatbelt, straps and support legs. Type approval: E5 03135
	Britax Baby Safe Plus – rear-facing child seat, secured with the ISOFIX fixture system. Type approval: E1 03301146	Britax Baby Safe Plus – rear-facing child seat, secured with the ISOFIX fixture system. Type approval: E1 03301146	Britax Baby Safe Plus – rear-facing child seat secured with the car's seatbelt. Type approval: E1 03301146
Group 1 9–18 kg (9–36 months)	Volvo Child seat – rear-facing child seat, secured with the car's seatbelt and straps. Use a protective cushion between the child seat and the dashboard. Type approval: E5 03135	Volvo Child seat – rear-facing child seat, secured with the car's seatbelt, straps and support legs. Type approval: E5 03135	Volvo Child seat – rear-facing child seat, secured with the car's seatbelt, straps and support legs. Type approval: E5 03135
	Britax Freeway – rear-facing child seat, secured with the ISOFIX fixture system and straps. Type approval: E5 03171	Britax Freeway – rear-facing child seat, secured with the ISOFIX fixture system and straps. Type approval: E5 03171	
Group 2/3 15–36 kg (3–12 years)	Volvo Booster cushion – with or without backrest. Type approval: E5 03139	Volvo Booster cushion – with or without backrest. Type approval: E5 03139	Volvo Booster cushion – with or without backrest. Type approval: E5 03139
		Volvo Integrated booster cushion – available as a factory fitted option. Type approval: E5 03168	

¹For information on activated/deactivated airbag (SRS), see page 18.

With regard to other child seats your car should be included in the manufacturer's enclosed list of vehicles or be universally approved in accordance with the ECE R44 legal requirement.



Child safety

Integrated booster cushion (option)

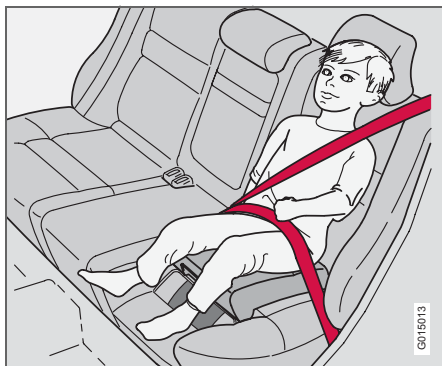

Volvo's integrated booster cushion for the outer rear seats is specially designed to provide optimum safety for children. Combined with the regular seatbelts the integrated booster cushion is approved for children weighing between 15 and 36 kg.

Raising the booster cushion

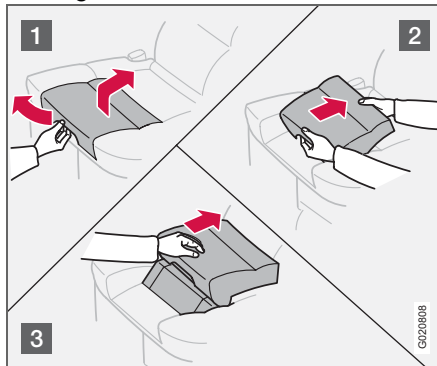

- Pull that handle to raise the booster cushion (1).
- Grasp the cushion with both hands and push it backwards (2).
- Push until it locks in place (3).



WARNING

The booster cushion must be in the locked position before the child is placed there.

Check that:

- the booster cushion in locked in position.
- the seatbelt is in contact with the child's body and is not slack or twisted, and that

the seatbelt is positioned correctly across the shoulder

- the hip strap is low across the hips for optimum protection.
- the seatbelt does not lie across the child's throat or below the shoulder
- Carefully adjust the position of the head restraint to suit the child.



WARNING

Repair or replacement should only be performed by an authorised Volvo workshop. Do not make any modifications or additions to the booster cushion.

If an integrated booster cushion has been subjected to a major load, such as in conjunction with a collision, the entire booster cushion must be replaced. Even if the booster cushion appears to be undamaged, it may not afford the same level of protection. The booster cushion must also be replaced if it is heavily worn.



Lowering the booster cushion

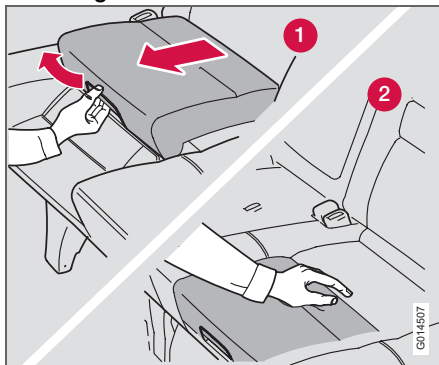

- Pull the handle (1).
- Lower the seat and press until it locks (2).

NOTE

Remember to stow away the booster cushion before lowering the rear seat backrest.

ISOFIX fixture system for child seats (option)

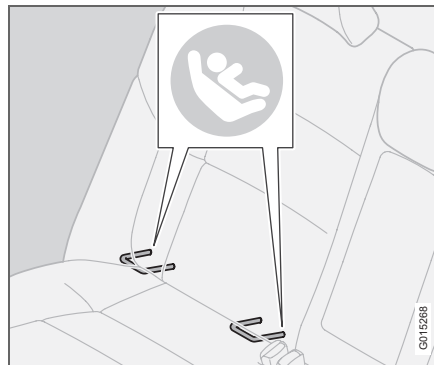

Mounting points for the ISOFIX fixture system are concealed behind the lower section of the rear seat backrest, in the outer seats.

The location of the mounting points is indicated by symbols in the backrest upholstery (see illustration above).

Press the seat cushion down to access the mounting points.

Always follow the manufacturer's installation instructions when connecting a child seat to the ISOFIX mounting points.

Overview, left-hand drive cars	34
Overview, right-hand drive cars	36
Driver's door control panel	38
Combined instrument panel	39
Indicator and warning symbols	40
Information display	44
Electrical socket	45
Lighting panel	46
Left-hand stalk switch	49
Right-hand stalk switch	51
Cruise control (option)	53
Steering wheel keypad (option)	54
Steering wheel adjustment, hazard warning flashers	55
Parking brake	56
Power windows	57
Rearview and door mirrors	59
Power sunroof (option)	63
Personal preferences	65

INSTRUMENTS AND CONTROLS



02



02 Instruments and controls

Overview, left-hand drive cars

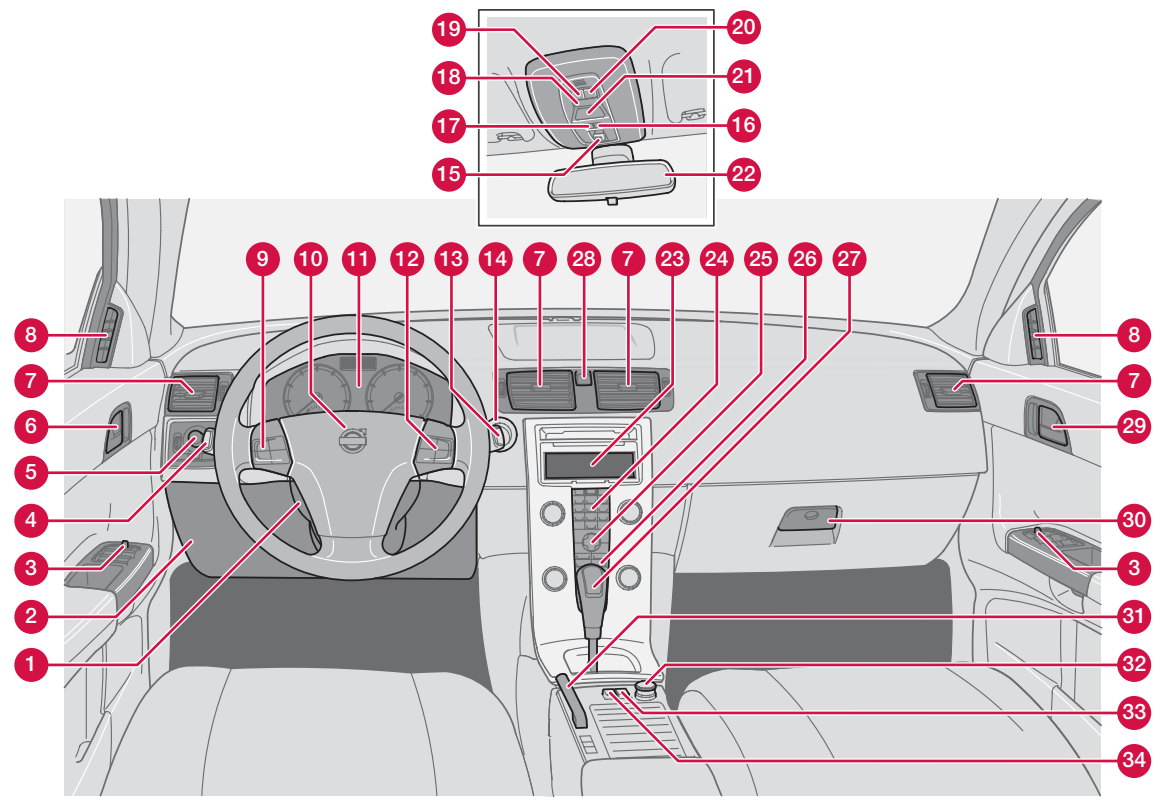

G010488



Overview, left-hand drive cars

1. Steering wheel adjustment
2. Bonnet release
3. Control panel
4. Direction indicators, main beam, trip computer
5. Lighting, fuel filler flap opener
6. Door handle, lock button
7. Air vents in dashboard
8. Air vent for side window
9. Cruise control
10. Horn, airbag
11. Combined instrument panel
12. Keypad for infotainment system
13. Windscreen wipers and washer, headlamp washers
14. Ignition switch
15. Sunroof controls
16. No function
17. Deactivation of alarm detectors, deadlocks
18. Switch for interior lighting
19. Reading lamp, left-hand side
20. Reading lamp, right-hand side
21. Seatbelt reminder and passenger seat airbag indicator
22. Interior rearview mirror
23. Display for climate control and infotainment system
24. Infotainment system
25. Controls for climate control, infotainment system and personal preferences
26. Climate control
27. Gear lever
28. Hazard warning flashers
29. Door handle
30. Glovebox
31. Parking brake
32. Electrical socket/cigarette lighter
33. Blind Spot Information System, BLIS
34. Switch, optional equipment



02 Instruments and controls

Overview, right-hand drive cars

02

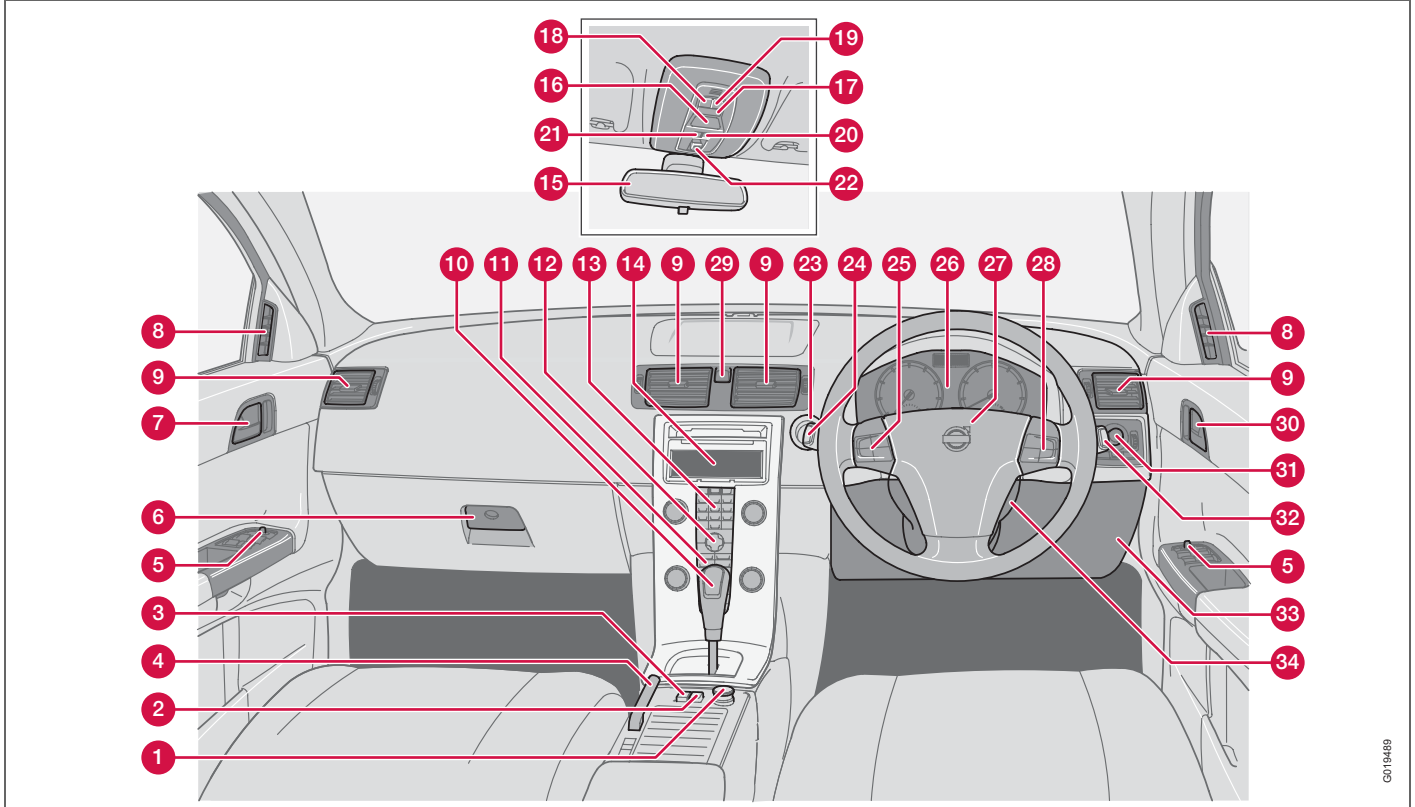

G016489



Overview, right-hand drive cars

1. Electrical socket, cigarette lighter
2. Blind Spot Information System, BLIS
3. Switch, optional equipment
4. Parking brake
5. Control panel
6. Glovebox
7. Door handle
8. Air vent for side window
9. Air vents in dashboard
10. Gear lever
11. Climate control
12. Controls for climate control, infotainment system and personal preferences
13. Infotainment system
14. Display for climate control and infotainment system
15. Interior rearview mirror
16. Seatbelt reminder and passenger seat airbag indicator
17. Switch for interior lighting
18. Reading lamp, left-hand side
19. Reading lamp, right-hand side
20. No function
21. Deactivation of alarm detectors, deadlocks
22. Sunroof controls
23. Ignition switch
24. Windscreen wipers and washers, headlamp washers
25. Cruise control
26. Combined instrument panel
27. Horn, airbag
28. Keypad for infotainment system
29. Hazard warning flashers
30. Door handle, lock button
31. Lighting, fuel filler flap opener
32. Direction indicators, main beam, trip computer
33. Bonnet release
34. Steering wheel adjustment



Driver's door control panel

Driver's door control panel

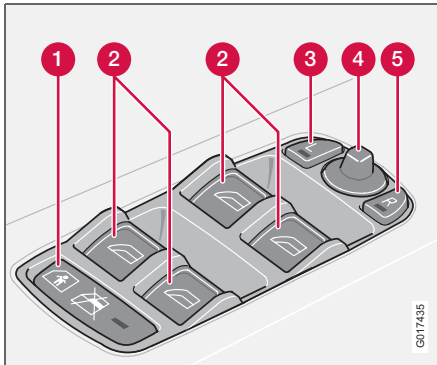

1. Blocking switch for rear power windows (standard)
Electric child locks (option)
2. Power windows
3. Door mirror, left-hand side
4. Door mirrors, setting
5. Door mirror, right-hand side



Combined instrument panel

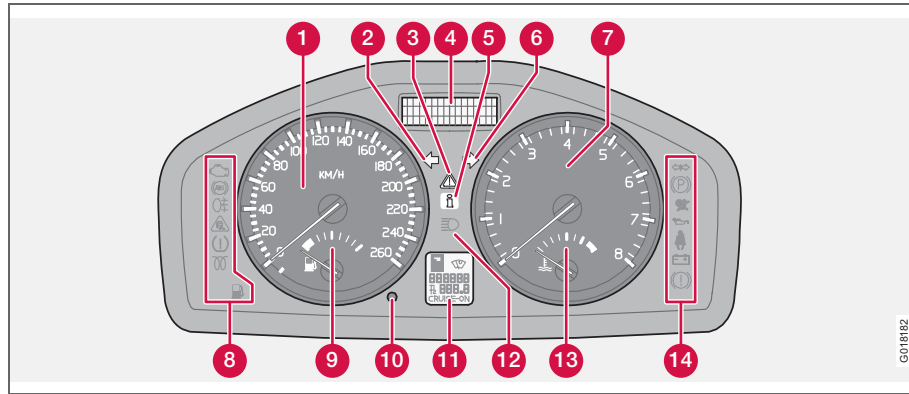

1. Speedometer.
2. Direction indicators, left.
3. Warning symbol.
4. Information display – The display presents information and warning messages and outside temperature. When the ambient temperature is between +2 °C and –5 °C, a snowflake symbol appears on the display. This warns of icy roads. The outside temperature gauge may show a slightly high reading after the car has been stationary.
5. Information symbol.
6. Direction indicator, right.
7. Tachometer – Indicates engine speed in thousands of revolutions per minute (rpm).
8. Indicator and warning symbols.
9. Fuel gauge.
10. Button for trip meter – Used to measure short distances. Press the button to switch between trip meters T1 and T2. Press and hold (more than 2 seconds) to zero the active trip meter.
11. Display – Display for automatic gear position, rain sensor, odometer, trip meter and cruise control.
12. Main beam indicator.
13. Temperature gauge – Displays the temperature of the engine cooling system. A message will appear on the display if the temperature becomes too high and the gauge goes into the red zone. Bear in mind that extra lights placed in front of the air intake, for example, reduce the cooling capacity at high outside temperatures and high engine loads.
14. Indicator and warning symbols.

Indicator and warning symbols

Functionality check, symbols

All indicator and warning symbols¹ illuminate when the ignition key is turned to position **II** before starting. This is to check that the symbols are working. When the engine starts, all the symbols should go out except the handbrake symbol, which extinguishes when the handbrake is released.



If the engine does not start within five seconds, all symbols extinguish except the symbols for a fault in the car's emissions system and for low oil pressure. Certain symbols may have no function, depending on the car's specifications.

Symbols in the centre of the instrument panel

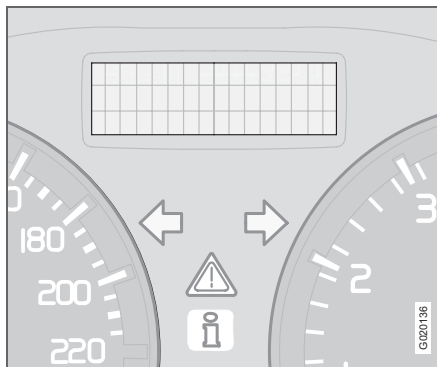

The red warning symbol illuminates when a fault has been indicated which could affect the safety and/or driveability of the car. An explanatory text is shown

on the information display at the same time. The symbol remains visible until the fault has been rectified but the text message can be cleared with the **READ** button, see page 44. The warning symbol can also illuminate in conjunction with other symbols.

1. Stop in a safe place. Do not drive the car further.

2. Read the information on the information display. Implement the action in accordance with the message in the display. Clear the message using **READ**.

If the car is driven at a speed higher than 7 km/h then the warning symbol illuminates.



When one of the car's systems does not behave as intended, the yellow information symbol illuminates and a text appears in the information display. The message text is cleared using the **READ** button, see page 44, or disappears automatically after a period of time (time depending on which function is indicated).

The yellow information symbol can also illuminate in conjunction with other symbols.

If the car is driven at a speed lower than 7 km/h then the information symbol illuminates.

NOTE

When a service message is shown, the symbol and message are cleared using the **READ** button, or disappear automatically after a time.

¹ For certain engine variants, the symbol for low oil pressure is not used. Warnings are given via display text, see page 186.



Indicator and warning symbols

Indicator symbols – left-hand side

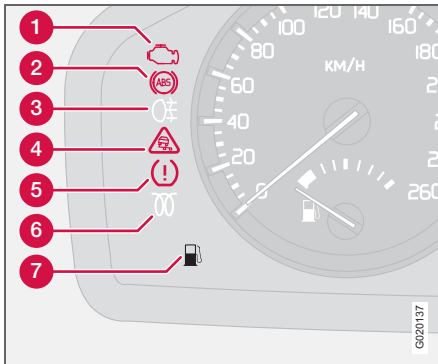

1. Fault in car's emissions system



Drive to an authorised Volvo workshop to have the system checked.

2. ABS fault



If this symbol illuminates, the system is not working. The car's regular brake system continues to work, but without the ABS function.

- Stop the car in a safe place and turn off the engine.
- Restart the engine.
- Drive to an authorised Volvo workshop to have the ABS checked if the symbol remains lit.

3. Rear fog lamp

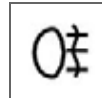

This symbol is lit when the rear fog lamp is on.

4. Stability system STC or DSTC



For information on the system's functions and symbols, see page 133.

5. No function

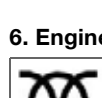

6. Engine preheater (diesel)

This symbol is lit during engine preheating. Preheating occurs when the temperature is below -2°C . The car can be started once the symbol extinguishes.

7. Low level in fuel tank



This symbol illuminates when there are approximately 8 litres of usable fuel left in a petrol-engined car, or approximately 7 litres in a diesel-engined car.



Indicator and warning symbols

Indicator symbols – right-hand side

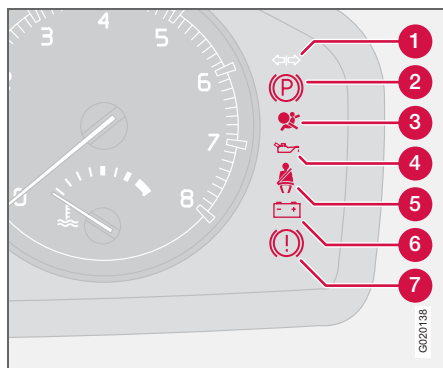

1. Indicator symbol for trailer

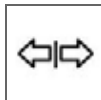

This symbol flashes when the direction indicators are used and a trailer is coupled. If the symbol does not flash, one of the lamps on the trailer or the car is defective.

2. Parking brake applied



The symbol illuminates when the parking brake is applied. Always pull the parking brake lever to the end position.

NOTE

The symbol illuminates irrespective of how hard the parking brake is applied.

3. Airbags – SRS



If this symbol remains on or illuminates while driving, it means a fault has been detected in the seatbelt buckle, SRS, SIPS, or IC system. Drive directly to an

authorised Volvo workshop to have the system checked.

4. Low oil pressure¹



If this symbol illuminates up while driving, the engine oil pressure is too low. Stop the engine immediately and check the engine oil level, top up if necessary. If the

symbol illuminates and the oil level is normal, contact an authorised Volvo workshop.

5. Seatbelt reminder



This symbol illuminates if someone in a front seat has not put on their seatbelt or if someone in a rear seat has taken off their seatbelt.

¹ For certain engine variants, the symbol for low oil pressure is not used. Warnings are given via display text, see page 186.

6. Alternator not charging



If this symbol illuminates while driving, a fault has occurred in the electrical system. Contact an authorised Volvo workshop.

7. Fault in brake system



If this symbol illuminates, the brake fluid level may be too low.

- Stop the car in a safe place and check the level in the brake fluid reservoir, see page 189. If the level in the reservoir is below MIN, the car should not be driven any further. Transport the car to an authorised Volvo workshop to have the brake system checked.



If the BRAKE and ABS symbols illuminate at the same time, there may be a fault in the brake force distribution system.



- Stop the car in a safe place and turn off the engine.
- Restart the engine.



Indicator and warning symbols

- If both symbols extinguish, continue driving.
- If the symbols remain on, check the level in the brake fluid reservoir. See page 189.
- If the brake fluid level is normal but the symbols are still lit, the car can be driven, with great care, to an authorised Volvo workshop to have the brake system checked.
- If the level in the reservoir is below **MIN** then the car should not be driven any further. Have the car transported to an authorised Volvo workshop to have the brake system checked.



WARNING

If the BRAKE and ABS symbols are lit at the same time, there is a risk that the rear end will skid during heavy braking.

Reminder – doors not closed

If one of the doors, the bonnet¹ or the tailgate is not properly closed, the driver will be reminded of this.

Low speed



If the car moves at a speed less than approx. 7 km/h, the information symbol illuminates and **DRIVER DOOR OPEN,**

PASSENGER DOOR OPEN,
LEFT REAR DOOR OPEN, BONNET OPEN
or **RIGHT REAR DOOR OPEN,** is shown in the display. Stop the car safely as soon as possible and close the door or bonnet.

High speed



If the car is moving faster than approx. 7 km/h, the symbol illuminates and one of the texts indicated in the previous paragraph appears in the display.

Tailgate reminder



If the tailgate is open, this information symbol will illuminate and **TAILGATE OPEN** will appear on the display.

¹ Only cars with alarms



Information display

Messages

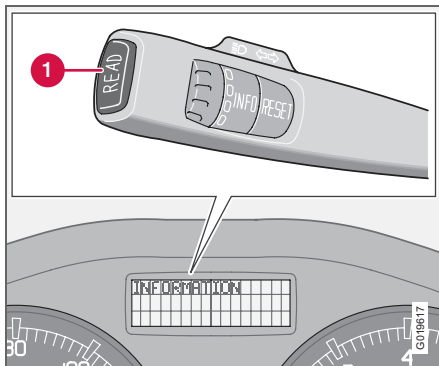

When a warning or indicator symbol come, a message appears on the information display.

- Press the **READ** button (1).

Switch between messages with the **READ** button. Fault messages are stored in the memory until the fault is rectified.

NOTE

If a warning message appears while you are using the trip computer, the message must be read (press **READ**) before the previous activity can be resumed.

Message	Specification
STOP SAFELY	Stop the car in a safe manner and turn off the engine. Serious risk of damage.
STOP ENGINE	Stop the car in a safe manner and turn off the engine. Serious risk of damage.
SERVICE URGENT	Have the car checked by an authorised Volvo workshop immediately.
SEE MANUAL	Read the Owner's Manual.
SERVICE REQUIRED	Have the car checked by an authorised Volvo workshop as soon as possible.
BOOK TIME FOR REGULAR SERVICE	Time to book regular service at an authorised Volvo workshop.
TIME FOR REGULAR SERVICE	Time for regular service at an authorised Volvo workshop. The timing is determined by the number of kilometres driven, number of months since the last service, engine running time and oil grade.
MAINTENANCE OVERDUE	If the service intervals are not followed then the warranty does not cover any damaged parts. Contact an authorised Volvo workshop for service.
CHECK OIL LEVEL	Check the oil level. The message is shown every 10 000 km (certain engine variants). For information on checking the oil level, see page 187.
SOOT FILTER FULL – SEE MANUAL	Diesel particle filter requires regeneration, see page 121.
STC/DSTC SPIN CONTROL OFF	The function of the stability and traction control system is reduced, see page 134 for more variants.



Electrical socket

12 V electrical socket

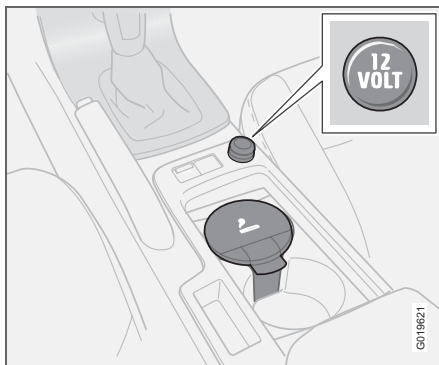

The electrical socket can be used for 12 V accessories, such as mobile phone chargers and coolers. The maximum current is 10 A. For the socket to supply current, the ignition key must be in at least position I.

WARNING

Always leave the plug in the socket when the socket is not in use.

Cigarette lighter (option)

Activate the lighter by pushing in the button. The button pops out when the lighter is hot. Pull out the lighter and light a cigarette on the heated coils.

Electrical socket in the rear seat

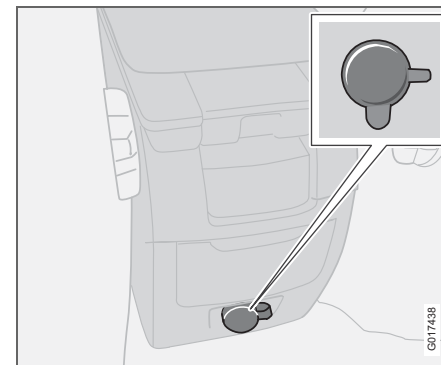

The electrical socket can be used for various accessories, such as mobile phone chargers and coolers.

NOTE

Cigarette lighter does not work in this socket.

It is designed for 12 V. The maximum current is 10 A. For the socket to supply current, the ignition key must be in at least position I.

WARNING

Always leave the plug in the socket when it is not in use.

Lighting panel

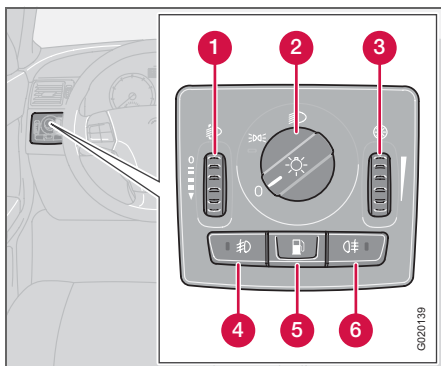

Position	Specification
0	Automatic/deactivated dipped beam. Only main beam flash.
	Position/parking lamps
	Automatic dipped beam. Main beam and main beam flash work in this position.

Headlamp levelling

The load in the car changes the vertical alignment of the headlamp beam, which could dazzle oncoming motorists. Avoid this by adjusting the height of the beam.

- Turn the ignition key to position **II**.
- Turn the headlamp control (2) to one of the end positions.
- Roll the control (1) up or down respectively to raise or lower beam alignment.

Cars with Bi-Xenon headlamps¹ have automatic headlamp levelling, so there is no control (1).

Position/parking lamps

Position/parking lamps can be switched on irrespective of ignition key position.

- Turn the headlamp control (2) to the centre position.

When the ignition key is in position **II** the position/parking lamps and number plate lighting are always on.

Headlamps

Automatic dipped beam (certain countries)

Dipped beam comes on automatically when the ignition key is turned to position **II**, except when the headlamp control (2) is in

¹ Option

the centre position. If necessary, the automatic dipped beam can be deactivated by an authorised Volvo workshop.

Automatic dipped beam, main beam

- Turn the ignition key to position **II**.
- Dipped beam is activated by means of turning the headlamp control (2) clockwise to the end position.
- Main beam is activated by means of moving the left-hand stalk switch towards the steering wheel to the end position and releasing it, see page 49.

The lamps are switched off automatically when the ignition key is turned to position **I** or **0**.

Instrument lighting

The instrument lighting is switched on when the ignition key is in position **II** and the headlamp control (2) is in one of the end positions. The lighting is automatically dimmed during the day and can be controlled manually at night.

- Roll the control up or down (3) for brighter or dimmer lighting.

Enhanced display lighting

To facilitate reading the odometer, trip meter, clock and outside temperature gauge, these illuminate when the car is unlocked and when the key is removed from the ignition switch.



Lighting panel

The displays extinguish when the car is locked.

Fog lamps

i NOTE

Regulations for use of fog lamps vary from country to country.

Front fog lamps (option)

The front fog lamps can be switched on along with the headlamps or the position lamps/parking lamps.

- Press the button (4).

The light in the button (4) illuminates when the front fog lamps are switched on.

Rear fog lamp

The rear fog lamp can only be switched on with the headlamps or the front fog lamps.

- Press the button (6).

The rear fog lamp indicator symbol on the combined instrument panel and the light in the button (6) illuminate when the rear fog lamp is switched on.

Fuel filler flap

Press button (5) to open the fuel filler flap when the car is unlocked, see page 108.

Active Bi-Xenon Lights (option)

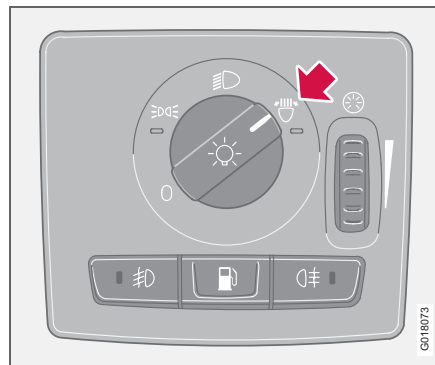

Lighting panel, for Active Bi-Xenon Lights

If the car is equipped with active headlamps (Active Bi-Xenon Lights, ABL) the light from the headlamps follows the steering wheel movement in order to provide maximum lighting in bends and junctions and so provide increased safety.

The LED  illuminates when the function is activated, the LED flashes and an error message is shown on the information display in the event of a malfunction. The function is only active in twilight or darkness and only when the car is moving.

The function can be deactivated/activated with the headlamp control.



Headlamp pattern with function deactivated (left) and activated (right) respectively



Lighting panel

Brake light

The brake light automatically comes on during braking.

Emergency brake light and automatic hazard warning flashers, EBL¹

Emergency Brake Lights (EBL) are activated in the event of heavy braking or if the ABS brakes are activated. This function means that the brake light flashes to immediately alert cars travelling behind.

The system is activated if ABS is used for more than 0.5 seconds or in the event of heavy braking, however, only when braking from speeds above 50 km/h. When the speed of the car is lower than 30 km/h the brake lights shine normally again and the hazard warning flashers are switched on automatically. The hazard warning flashers remain on until the car accelerates again but can be deactivated with the button for hazard warning flashers, see page 55.

¹ Certain markets



Left-hand stalk switch

Stalk switch positions

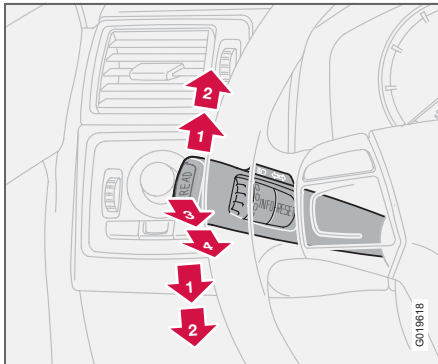

1. Short flash sequence, direction indicators
2. Continuous flash sequence, direction indicators
3. Main beam flash
4. Switching, main and dipped beam, and home safe lighting

Direction indicators

Continuous flash sequence

- Move the stalk switch up or down to end position (2).

The stalk switch remains in its end position and is moved back manually, or automatically by steering wheel movement.

Short flash sequence

- Move the stalk switch up or down to position (1) and release.

The direction indicators flash three times and the stalk switch returns to its home position.

Switching, main and dipped beam

The ignition key must be in position II for main beam to be switched on.

- Turn the headlamp control clockwise to the end position, see page 46.
- Move the stalk switch towards the steering wheel to the end position (4) and release.

Main beam flash

- Move the stalk switch gently towards the steering wheel to position (3).

Main beam comes on until the stalk switch is released. Main beam flash only works when the ignition key is inserted in the ignition switch.

Home safe lighting

Some exterior lights can be kept lit and serve as home safe lighting after the car has been locked. The standard delay is 30 seconds,¹ but can be changed to 60 or 90 seconds. See page 66.

¹ Factory settings

- Remove the key from the ignition switch.
- Move the stalk switch towards the steering wheel to the end position (4) and release.
- Get out of the car and lock the door.

Left-hand stalk switch

Trip computer (option)

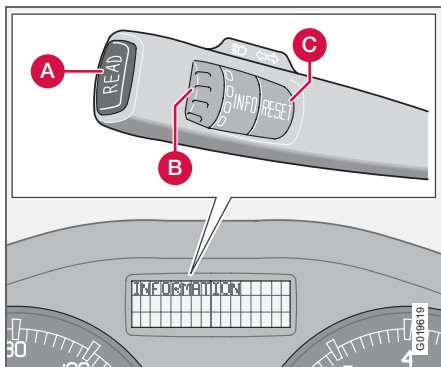

Controls

To scroll through trip computer information, turn the thumbwheel (B) in steps, either upward or downward. Continue turning to return to the starting point.

NOTE

If a warning message interrupts while you are using the trip computer, this message must be acknowledged. Acknowledge by pressing the **READ** button (A) and revert to the trip computer function.

Functions

The trip computer displays the following information:

- **AVERAGE SPEED**
- **ACTUAL SPEED MPH**
- **INSTANTANEOUS**
- **AVERAGE**
- **KILOMETRES TO EMPTY TANK**
- **STC/DSTC**, see page 133

AVERAGE SPEED

When the ignition is switched off, the average speed is stored and used as the basis of the new value when you continue driving. Reset using the **RESET** button (C).

ACTUAL SPEED MPH¹

Current speed is displayed in mph.

INSTANTANEOUS

Current fuel consumption is calculated every second. The information on the display is updated every couple of seconds. When the car is stationary, "----" appears on the display. During the period for regeneration² fuel consumption may increase, see page 121.

¹ Certain countries

² Only applies to diesel cars with particle filter.

AVERAGE

The average fuel consumption is stored when the ignition is switched off and remains until the function is reset. Reset using the **RESET** button (C).

NOTE

There may be a slight error in the reading if a fuel-driven heater is used.

KILOMETRES TO EMPTY TANK

The range to empty is calculated based on the average fuel consumption over the last 30 km. When the range to empty is shorter than 20 km then "----" is shown on the display.

NOTE

There may be a slight error in the reading if fuel consumption is changed due to a change in driving style or if a fuel-driven heater is used for example.

Resetting

- Select **AVERAGE SPEED** or **AVERAGE**
- Press and hold the **RESET** button (C) for at least five seconds to reset the average speed and average consumption at the same time.



Right-hand stalk switch

Windscreen wipers

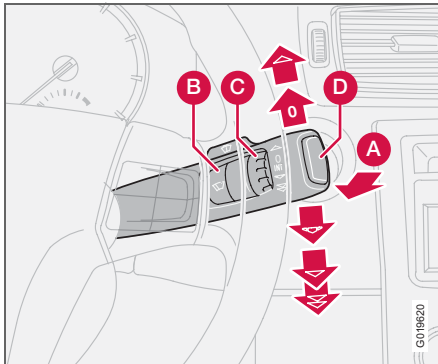

- A. Windscreen and headlamp washers
- B. Rain sensor – On/Off
- C. Thumbwheel
- D. Wiper and washer, rear window

Windscreen wipers off



The windscreen wipers are off when the stalk switch is in position **0**.

Single sweep



Raise the stalk switch to make a single sweep.

Intermittent wiping



You can adjust and set a suitable speed for intermittent wiping. Turn the thumbwheel (C) up for a shorter interval between sweeps. Turn it down to

increase the delay.

Continuous wiping

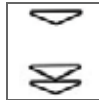

The wipers sweep at normal speed.

The wipers sweep at high speed.

! IMPORTANT

Before activating the wipers during winter - ensure that the wiper blades are not frozen in so that any snow or ice on the windscreen (and rear window) is scraped away.

! IMPORTANT

Use plenty of washer fluid when the wipers are cleaning the windscreen. The windscreen must be wet when the windscreen wipers are operating.

Windscreen/headlamp washer

Pull the stalk switch towards the steering wheel to start the windscreen and headlamp washers. The wipers will make several extra sweeps once the stalk is released.

High-pressure headlamp washing (option in certain markets)

High-pressure headlamp washing consumes a large quantity of washer fluid. To save fluid, the headlamps are washed as follows.

Dipped beam selected with the switch on lighting panel:

The headlamps are washed the first time the windscreen is washed. Within the next ten minutes, they are washed every fifth wash of the windscreen. If more than ten minutes passes between washes, the headlamps are washed every time.

Parking/position lamps selected with the switch on the lighting panel:

- Bi-Xenon headlamps are only washed every fifth wash cycle irrespective of the time that elapses.

- Halogen headlamps are not washed.

The switch on the lighting panel is in position **0**:

- Bi-Xenon headlamps are only washed every fifth wash cycle irrespective of the time that elapses.
- Halogen headlamps are not washed.

Right-hand stalk switch

Rear window wiper and washer

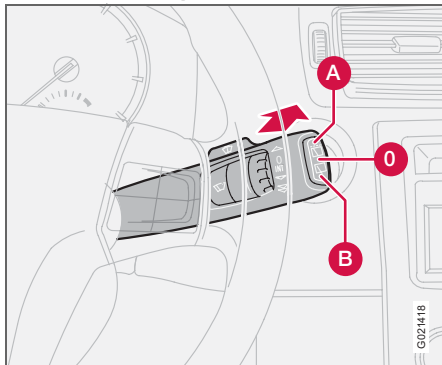

Move the stalk switch forward to start rear window washing and wiping. The wiper blade makes several extra sweeps once washing has finished. The button at the end of the stalk switch has three positions:

A. Intermittent wiping: Depress the top of the button.

0. Neutral position: Function deactivated.

B. Constant speed: Depress the bottom of the button.

Wiper – reversing

Engaging reverse gear while the windscreen wipers are on initiates intermittent rear window wiping. If the rear window wiper is already on at normal speed, no change is made.

The function for intermittent wiping for reverse can be deactivated. Contact an authorised Volvo workshop.

Rain sensor (option)

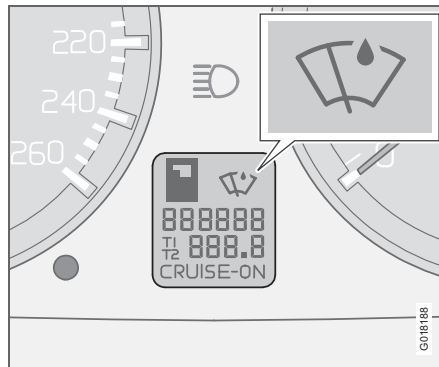

The rain sensor automatically activates the windscreen wipers based on how much water it detects on the windscreen. The sensitivity of the rain sensor can be adjusted using the thumbwheel (C), see the illustration on page 51.

Turn the thumbwheel upwards for higher sensitivity and downwards for lower sensitivity, (an extra sweep is made when the thumbwheel is turned upwards).

On/Off

When activating the rain sensor, the ignition key must be in position **I** or **II** and the wind-

screen wiper stalk switch must be in position **0**.

Activating the rain sensor:

- Press the button (B), see page 51. A display symbol indicates that the rain sensor is active.

To turn the rain sensor off, either:

- Press button (B)
- Press the stalk switch downward to another wiper program. If the stalk switch is raised, the rain sensor will remain active, the wipers make an extra sweep and then return to rain sensor mode when the stalk switch is released back to position **0** (not activated), see page 51.

The rain sensor is automatically deactivated when the key is removed from the ignition switch or five minutes after the ignition is switched off.



IMPORTANT

At an automatic car wash: Deactivate the rain sensor by pressing the button (B) while the ignition key is in position **I** or **II**. Otherwise, the windscreen wipers could start swiping and become damaged.

Thumbwheel

Use the thumbwheel to adjust the frequency of wiper sweeps when intermittent wiping is selected, or the sensitivity to rain when the rain sensor is selected.



Cruise control (option)

Activating

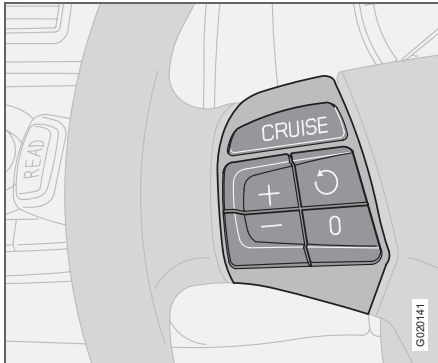

The controls for cruise control are to the left of the steering wheel.

Setting the desired speed:

- Press the **CRUISE** button. **CRUISE** is shown on the combined instrument panel.
- Touch + or – to lock the vehicle speed. **CRUISE-ON** appears in the combined instrument panel.

Cruise control cannot be engaged at speeds below 30 km/h or above 200 km/h.

Increasing or decreasing speed

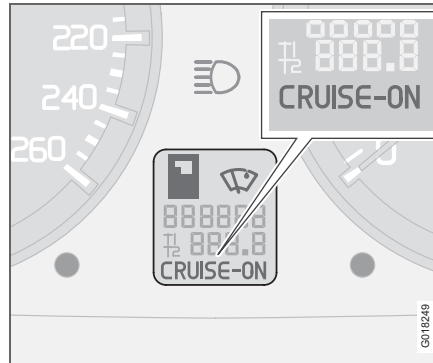

- Increase or decrease the locked speed by pressing and holding + or –. The speed of the car when the button is released is set as the new speed.

Pressing (less than half a second) + or – changes the speed 1 km/h or 1.6 km/h¹.

NOTE

A temporary increase in speed (less than one minute) using the accelerator, such as while overtaking, does not affect the cruise control setting. When you release the accelerator, the car will return to the programmed speed.

¹ Depending on engine type

Temporary disengagement

- Press **0** to disengage the cruise control temporarily. **CRUISE** will be shown on the combined instrument panel. The speed set earlier is stored in the memory.

The cruise control is also temporarily disengaged when:

- the brake pedal or clutch pedal is depressed
- speed falls below 25–30 km/h when travelling uphill¹
- the gear selector is moved to position **N**
- wheel spin or wheel lock-up occurs
- a temporary increase in speed lasts longer than one minute.

Return to the set speed



- Press this button to resume the previously set speed. **CRUISE-ON** appears on the combined instrument panel.

Disengaging

- Press **CRUISE** to disengage the cruise control. **CRUISE-ON** goes out on the combined instrument panel.



Steering wheel keypad (option)



The four buttons at the bottom of the steering wheel keypad control the radio and the phone. The function of a button depends on which system is active. The steering wheel keypad can be used to scroll between preset stations, change CD tracks and adjust the volume.

- Press and hold one of the arrow keys to fast forward/reverse or search for the next station.

The phone must be switched on to adjust audio system settings. It must be activated with the **ENTER** key to enable control of the phone functions with the arrow keys.

To return to Audio only, press **EXIT**.



Steering wheel adjustment, hazard warning flashers

Steering wheel adjustment

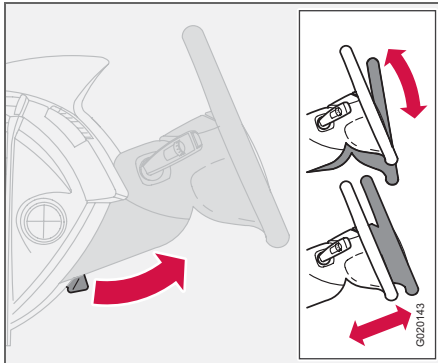

The steering wheel can be adjusted for both height and reach.

- Pull the lever towards you to release the steering wheel.
- Adjust the steering wheel to the position that suits you best.
- Push back the lever to fix the steering wheel in place. If the lever is stiff, press the steering wheel lightly at the same time as you push the lever back.

WARNING

Adjust the steering wheel before driving off, never while driving. Before driving, check that the steering wheel is fixed in position.

Hazard warning flashers

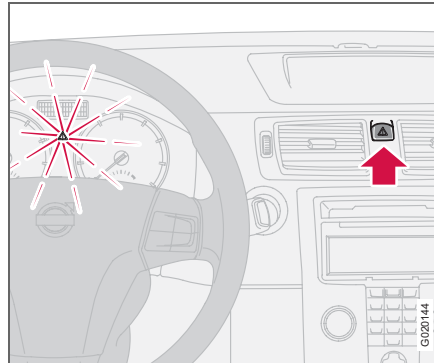

Use the hazard warning flashers (all direction indicators flash) when the car is stopped where it could be a traffic hazard or obstruction. Press the button to activate the function.

A sufficiently violent collision or heavy braking activates the hazard warning flashers automatically, see page 48. The function can be deactivated with the button.

NOTE

Regulations regarding the use of hazard warning flashers vary from country to country.



Parking brake

Parking brake (handbrake)

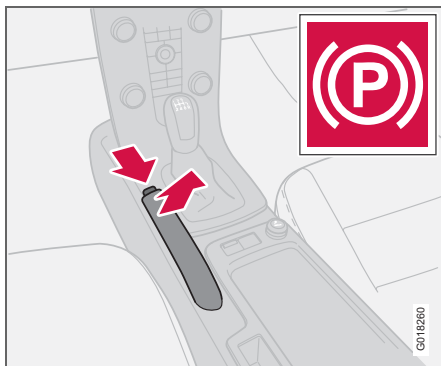

The lever is located between the front seats.

NOTE

The warning lamp symbol in the combined instrument panel illuminates irrespective of how hard the parking brake is applied.

How to Apply the parking brake

- Press the foot brake pedal down firmly.
- Pull up the parking brake lever up firmly to its full extent.
- Release the foot brake pedal and make sure that the car is at a standstill position.

- If the vehicle rolls, the parking brake lever must be pulled more firmly.

When parking a vehicle always put the gear selector in **1st** gear (for manual transmission) or **P** (for automatic transmission)

Parking on a hill

If the car is parked facing uphill; turn the wheels away from the kerb.

If the car is parked facing downhill; turn the wheels toward the kerb.

How to release the parking brake

- Press the foot brake pedal down firmly.
- Pull the parking brake lever up slightly, press the button, release the parking brake lever and release the button.



Power windows

Operation

The power windows are operated using the controls in the doors. The ignition key must be in position I or II for the power windows to operate.

The windows continue to work for a limited amount of time when the car is stopped and ignition key is removed, provided none of the doors is opened. Operate the windows with caution.

To open a window:

- Depress the front of the control.

To close a window:

- Raise the front of the control.

Remote control and lock buttons

To operate the power windows with lock buttons and remote control, see page 100 and page 109.

WARNING

Make sure that children and other passengers cannot be trapped in any way when closing the windows. Pay close attention if the rear door windows are controlled from the driver's door or if the windows are closed with the remote control.

Driver's door

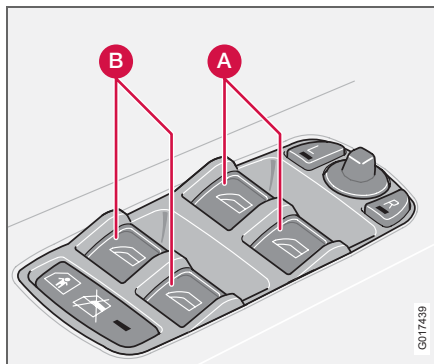

Controls, power windows, front (A) and rear (B).

The driver can operate all of the power windows from the driver's seat.

The windows can be opened and closed in two ways:

Manual operation

Depress one of the controls (A) or (B) gently or raise it gently. The power window opens or closes as long as the switch is actuated.

Automatic operation

Fully depress one of the controls (A) or raise it, then release. The side window will then open or close automatically. If the window is

obstructed by an object, the movement will stop.

WARNING

The function that interrupts the movement of the windows in the event of them being blocked works with both automatic and manual closing, although not with pinch protection deployed.

WARNING

If there are children in the car:

Remember to switch off the supply to the power windows by removing the ignition key if the driver leaves the car.

Make sure that children and other passengers cannot be trapped in any way when closing the windows.



Power windows

Blocking power windows in the rear doors

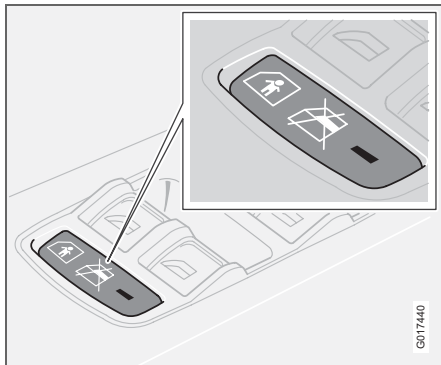

Blocking rear power windows and electric child safety locks¹.

The light in the switch is lit

The rear door windows can only be operated from the driver's door.

The light in the switch is extinguished

The rear door windows can be operated both with the control on each rear door and with the controls on the driver's door.

NOTE

If the car has electric child safety locks on the rear doors, the light indicates that these are also activated. The doors then cannot be opened from the inside. A text message is shown on the display when the electric child safety locks are activated.

Front passenger seat

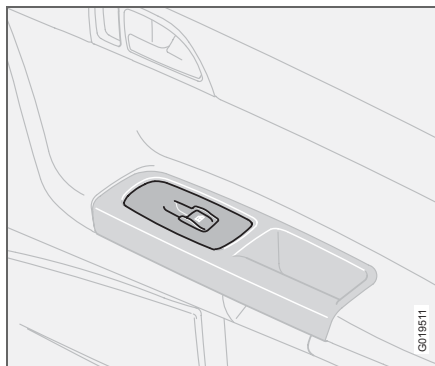

Front passenger seat

The control in the front passenger door operates that window only.

Rear power windows

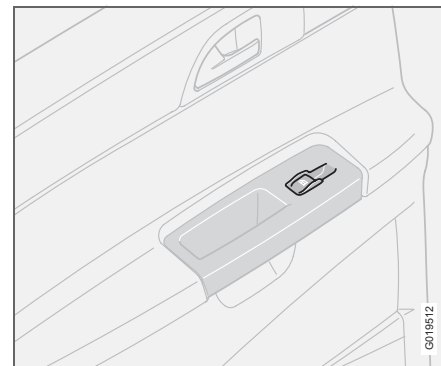

The rear door windows can be operated with the control on each door or with the switch on the driver's door. If the light with the switch for blocking the rear power windows (located in the control panel in the driver's door) is lit, the rear door windows can only be operated from the driver's door. The windows in the rear doors are operated in the same way as the windows in the front doors.

¹ Option



Rearview and door mirrors

Interior rearview mirror

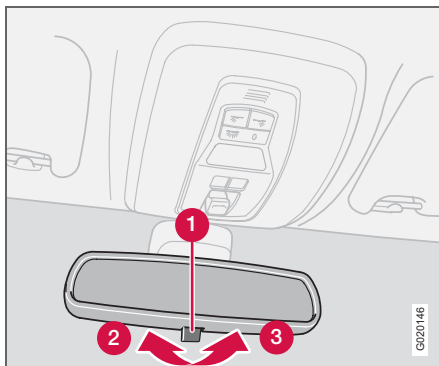

Bright light from behind could be reflected in the rearview mirror and dazzle the driver. Use dimming when disturbed by light from behind.

Dipping

1. Control for dimming
2. Normal position
3. Dimmed position.

Automatic dimming (option)

Bright light from behind is automatically dimmed by the rearview mirror. The control (1) is not available in mirrors with automatic dimming.

Rearview mirror with compass (option on certain markets)

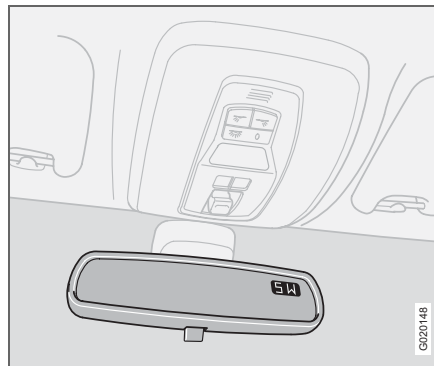

The upper right-hand corner of the rearview mirror has an integrated display that shows the compass direction in which the front of the car is pointing. Eight different directions are shown with English abbreviations: **N** (north), **NE** (north east), **E** (east), **SE** (south east), **S** (south), **SW** (south west), **W** (west) and **NW** (north west).

Calibrating the compass

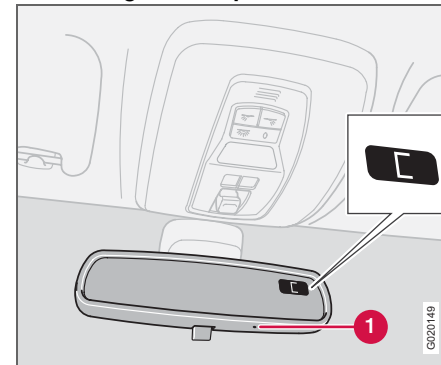

The earth is divided into 15 magnetic zones. The compass is set for the geographical area to which the car was delivered. The compass should be calibrated if the car is moved across several magnetic zones.

- Stop the car in a wide open area with the engine running at idling speed.
- Press and hold button (1) for at least 6 seconds. Following which, the sign **C** is shown (the button is concealed, so use a paper clip for example to press it in).
- Press and hold button (1) for at least 3 seconds. The number for the current magnetic zone is displayed.



02 Instruments and controls

Rearview and door mirrors

- Press the button (1) repeatedly until the number for the required magnetic zone (1-15) is shown, refer to the map of magnetic zones for the compass.
- Wait until the display returns to showing the character C.
- Following which, press and hold the button in for 9 seconds and select L for left-hand drive cars and R for right-hand drive.
- Drive slowly in a circle with a maximum speed of 10 km/h until a compass direction is shown on the display, which indicates that the calibration is complete.

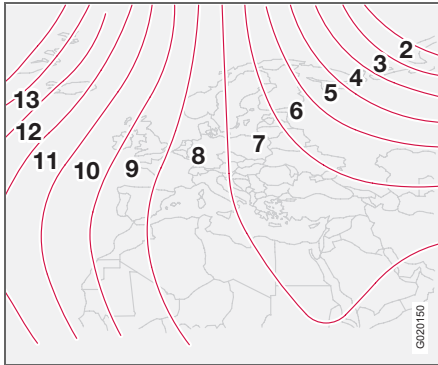

Magnetic zones, Europe

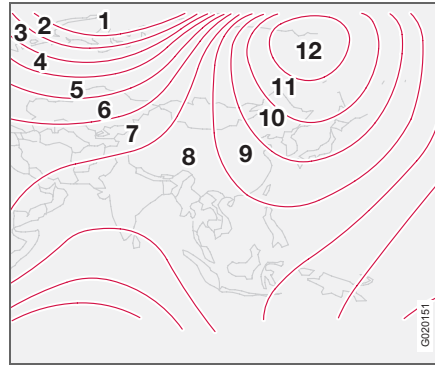

Magnetic zones, Asia



Magnetic zones, Australia

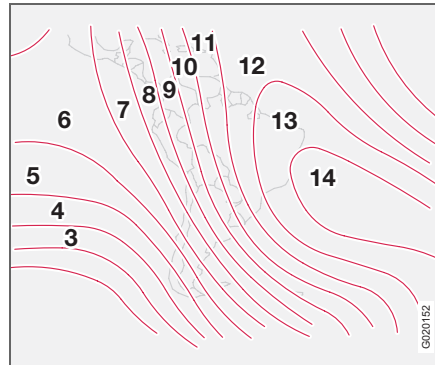

Magnetic zones, South America

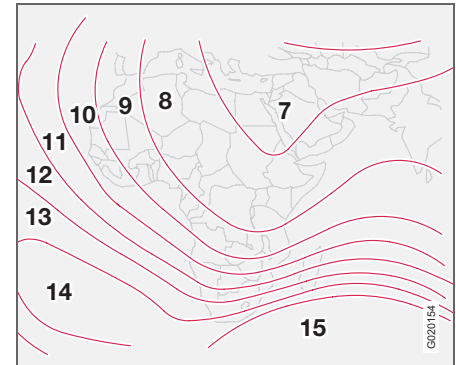

Magnetic zones, Africa



Rearview and door mirrors

Door mirrors

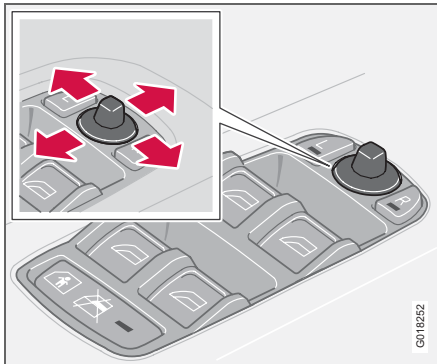

The controls for adjusting the two door mirrors are at the front of the driver's door armrest. The rearview mirrors can be operated in ignition position **I** and **II**.

- Press the **L** button for the left-hand door mirror or **R** for the right-hand door mirror. The light in the button illuminates.
- Adjust the position with the joystick in the centre.
- Press the **L** or **R** button again. The light goes out.

Retractable power door mirrors (option)

The mirrors can be retracted for parking and driving in narrow spaces. This can be done in ignition position **I** and **II**.

Retracting the mirrors

- Press the **L** and **R** button at the same time.
- Release the buttons. The mirrors automatically stop in the fully retracted position.



IMPORTANT

Do not use a scraper to remove ice from the mirrors as this could scratch the glass and the water and dirt-repellent coating¹ could be damaged. Use the defroster function instead, see page 73.

¹Option



WARNING

Both door mirrors are the wide angled type to provide optimal vision. Objects may appear further away than they actually are.

Folding out the mirrors

- Press the **L** and **R** button at the same time.

- Release the buttons. The mirrors automatically stop in the fully extended position.

Resetting to neutral

Mirrors that have been moved out of position by an external force must be reset to the neutral position for electric retracting and extending to work.

- Press the **L** and **R** button to retract the mirrors.
- Extend the mirrors again with the **L** and **R** button. The mirrors are now reset to the neutral.

Home safe and approach lighting

The light on the door mirrors (option) illuminates when the approach lighting or home safe lighting is activated.

Blind Spot Information System, BLIS (option)

BLIS is an information system that under certain conditions can help to draw the driver's attention to vehicles moving in the same direction in the so-called "blind spot", see page 138.



Rearview and door mirrors

Water and dirt-repellent coating (option)



The front windows and/or door mirrors are treated with a coating which improves the view in poor weather conditions. For information on maintenance, see page 175.

Rearview and door mirrors

In certain weather conditions, the function of the dirt-repellent coating is improved if the door mirror defrosters are used, see page 73 or page 77.

Heat the door mirrors:

- If they are covered with ice or snow.
- In heavy rain and dirty road conditions.
- If they are misted.



IMPORTANT

Do not use a metal ice scraper to remove ice from the windows. The water and dirt-repellent coating could be damaged. Use the defroster to remove ice from the mirrors. An ice scraper could scratch the mirror glass!



Power sunroof (option)

Open positions

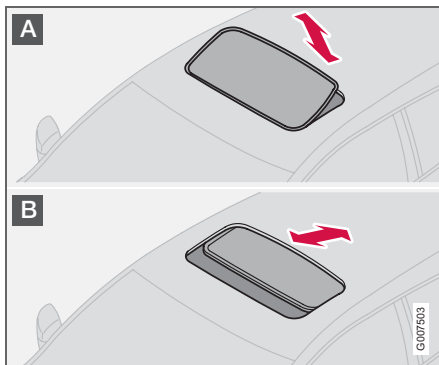

The sunroof controls are located in the roof panel. The sunroof can be opened to two positions:

- A. Ventilation position, up at the rear edge
- B. Sliding position, backwards/forwards

The ignition key must be in position **I** or **II**.

WARNING

If there are children in the car:
Switch off the supply to the power sunroof by removing the ignition key if the driver leaves the car.

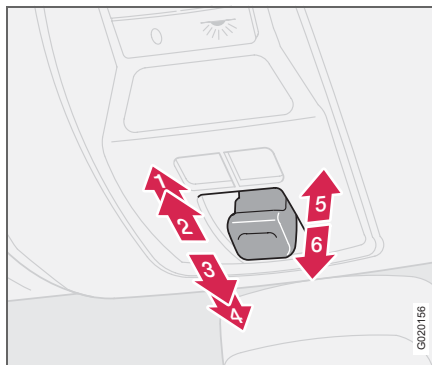

1. Opening, automatic
2. Opening, manual
3. Closing, manual
4. Closing, automatic
5. Opening, ventilation position
6. Closing, ventilation position

Ventilation position

Open:

- Press the rear edge of the control (5) upward.

Close:

- Pull the rear edge of the control (6) downward.

From ventilation position to fully open sunroof:

- Pull the control rearward to the end position (1) and release.

Sliding position

Automatic operation

- Pull the control past the point of resistance (2) to the rear end position (1) or past the point of resistance (3) to the forward end position (4) and release. The sunroof opens/closes completely.

Manual operation

Open:

- Pull the control rearward to the point of resistance (2). The sunroof moves toward the fully open position as long as the button is held in this position.

Close:

- Press the control forward to the point of resistance (3). The sunroof moves toward the closed position as long as the button is held in this position.

WARNING

The sunroof's pinch-protection function only operates during automatic closing, not manual closing.



Power sunroof (option)

Closing with remote control or lock button

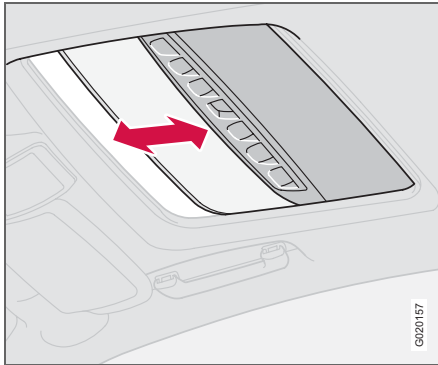

- One long press on the lock button closes the sunroof and all the windows. The doors and the tailgate are locked.

If you need to interrupt closing:

- Press the lock button again.

WARNING

Make sure that children or other passengers are not in danger of becoming trapped in any way when closing the sunroof with the remote control. Always operate the sunroof with caution.

Sunscreen

The sunroof features a manual, sliding interior sunscreen. The sunscreen slides back automatically when the sunroof is opened. Grip the handle and slide the screen forwards to close it.

Pinch protection

The sunroof's pinch protection function is activated if the hatch is blocked by an object. If blocked, the sunroof will stop and automatically open to the previous position.

WARNING

The sunroof's pinch protection function only operates during automatic closing, not during manual closing.

Make sure that nobody is in danger of becoming trapped in any way when closing the sunroof.



Personal preferences

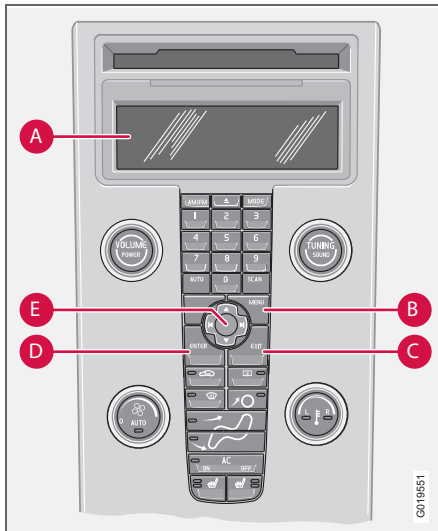

Control panel

Possible settings

Personal preferences can be set for some of the car's functions: the locks, climate control and audio functions. For audio functions, see page 210.

Control panel

A. Display

B. **MENU**

C. **EXIT**

D. **ENTER**

E. Navigation

Use

The settings are shown on the display (A).

Open the menu to enter settings:

- Press **MENU** (B).
- Scroll, for example, to **Car Settings** with the navigation button (E).
- Press **ENTER** (D).
- Select an alternative with the navigation button (E).
- Activate your selection with **ENTER**.

Close the menu:

- Press **EXIT** (C) for approximately one second.

Clock, adjustment

The hour and minute are each adjusted separately.

- Use the numbers on the keypad or "arrow up" or "arrow down" on the navigation button (E).
- Select the number for adjustment using "arrow right" or "arrow left" on the navigation button.
- Press **ENTER** to start the clock.

i NOTE

If the car has a 12-hour clock then **AM/PM** is selected using "arrow up" or "arrow down" after the final minute number has been adjusted.

Climate control settings

Auto blower adjust

The fan speed can be set to AUTO mode in cars equipped with ECC:

- Select from **Low**, **Normal** and **High**.

Recirculation timer

When the timer is active, the air recirculates for 3 – 12 minutes, depending on the outside air temperature.

- Select **On/Off** depending on whether you wish the recirculation timer to be active.



Personal preferences

Reset all

Resets the climate function options to the factory settings.

Car settings

Unlock confirm. light

The hazard warning flashers can provide feedback when the car is unlocked with the remote control. This function can be turned **On/Off**.

Lock confirm. light

The hazard warning flashers can provide feedback when the car is locked with the remote control. This function can be turned **On/Off**.

Automatic locking – doors

When the speed of the car exceeds 7 km/h the doors and tailgate can be locked automatically. This function can be turned **On/Off**. Pulling the door handle twice unlocks and opens the doors from the inside.

Unlock doors

There are two alternatives for unlocking:

- **All doors** – one press of the remote control unlocks both doors and the tailgate.
- **Driver's door first, then all others** – one press of the remote control unlocks the

driver's door. A second press then unlocks all the other doors and the tailgate.

Keyless entry (option in certain markets)

- **All doors** – all doors are unlocked at the same time.
- **Doors on the same side** – front and rear doors on the same side are unlocked simultaneously.
- **Both front doors** – both front doors are unlocked simultaneously.
- **One of the front doors** – any door or tailgate can be unlocked separately.

Simultaneous closing/opening of all windows

This function can be selected for the lock button on the remote control and the front doors' central locking button, as well as the outside door handle button on cars with the keyless system:

- **Auto-close all windows** – all windows and the tailgate are closed simultaneously with one long press on the lock button.

This function can be selected for the unlock button on the remote control and the front doors' central locking button:

- **Auto-open all windows** – all windows are opened simultaneously with one long press on the unlock button.

Approach lighting

Select the time the car's lights should remain on when the approach lighting button on the remote control is pressed. The following alternatives are available: **30/60/90 seconds**.

Home safe lighting

Select the time the car's lights should remain on when the left-hand stalk switch is pulled back after the ignition key has been removed. The following alternatives are available: **30/60/90 seconds**.

Information

- **VIN** - (Vehicle Identification Number). The car's unique identity number.
- **Number of keys** - The number of keys registered for the car is shown.



02

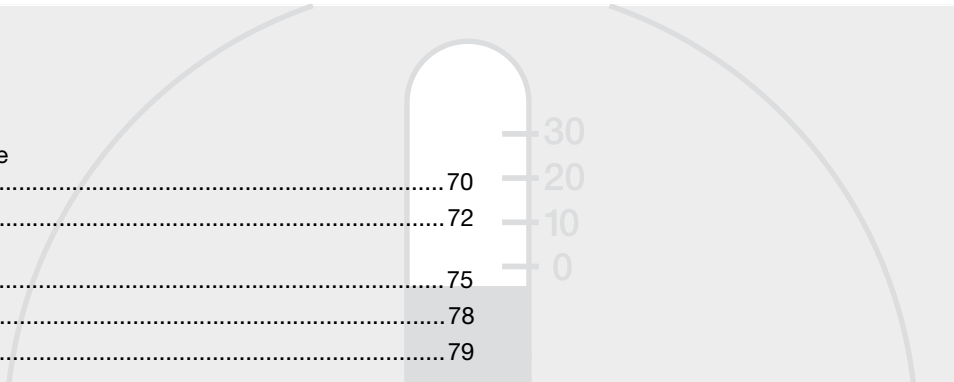

General information on climate control	70
Manual climate control, AC	72
Electronic climate control, ECC (option)	75
Air distribution	78
Fuel-driven heater (option)	79

CLIMATE CONTROL



03





General information on climate control

Air conditioning

The climate control system cools or heats, and dehumidifies the air entering the passenger compartment. The car is equipped with either manual (AC) or electronic climate control (ECC).

NOTE

The air conditioning system can be switched off, but to ensure the best possible air in the passenger compartment and prevent the windows from misting, it should always be on.

Misting windows

Remove misting on the insides of the windows by first using the defroster function.

To reduce the risk of misting, clean the windows with a normal window cleaning agent.

Ice and snow

Remove ice and snow from the climate control air intake (the grille between the bonnet and the windscreen).

Fault tracing and repair

Entrust fault tracing and repair of the climate control system to an authorised Volvo workshop only.

Refrigerant

The air conditioning system contains R134a refrigerant. This refrigerant contains no chlorine, which means that it is harmless to the ozone layer. The system must only be charged with R134a refrigerant. Have an authorised Volvo workshop carry out this work.

Passenger compartment filter

All air which enters the passenger compartment is first cleaned by a filter. This filter must be replaced regularly. Follow the Volvo Service Programme for the recommended replacement intervals. If the car is used in a severely contaminated environment, it may be necessary to replace the filter more often.

NOTE

There are several different types of passenger compartment filter. Ensure that the correct filter is installed.

Display

There is a display above the climate control panel that displays climate control settings.

Personal preferences

You can set preferences for two climate control functions:

- Fan speed in **AUTO** mode (applies only to cars with ECC).
- Recirculation timer for passenger compartment air.

For information about these settings, see page 65.



General information on climate control

Air vents in the dashboard

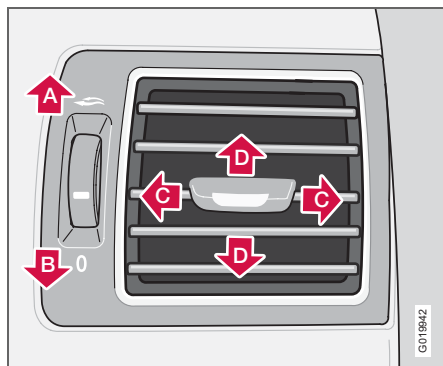

- A. Open
- B. Closed
- C. Lateral airflow
- D. Vertical airflow

Aim the outer vents towards the side windows to remove misting from the front side windows.

Cold weather: Close the centre vents for optimum comfort and best demisting.

ECC (option)

Actual temperature

The temperature you select corresponds to the physical experience with reference to factors such as air speed, humidity and solar radiation in and around the car.

Sensor location

- The sun sensor is on the top side of the dashboard.
- The temperature sensor for the passenger compartment is behind the climate control panel.
- The outside temperature sensor is located on the door mirror.
- The humidity sensor is located in the interior rearview mirror.

NOTE

Do not cover or block the sensors with clothing or other objects.

Side windows and sunroof

To ensure that the air conditioning works satisfactorily, close all side windows and the sunroof (if fitted).

Acceleration

The air conditioning system switches off temporarily at full throttle. You may feel a temporary rise in temperature.

Condensation

In warm weather, condensation from the air conditioning system may drip under the car. This is normal.

03



Manual climate control, AC

Control panel

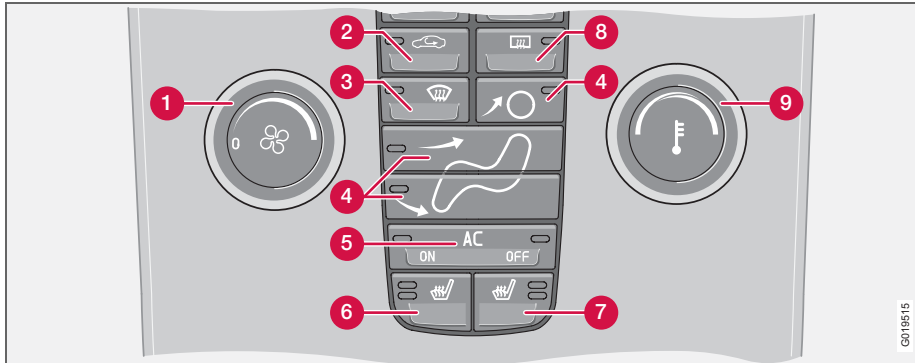

1. Fan
2. Recirculation
3. Defroster
4. Air distribution
5. **AC ON/OFF** – Air conditioning On/Off
6. Heated front left seat
7. Heated front right seat
8. Rear window and door mirror defrosters
9. Temperature

Functions

1. Fan

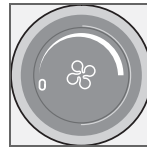

Increase or decrease the fan speed by turning the knob.

If the knob is turned anti-clockwise and the fan indicator in the display goes out, the fan and the air conditioning are switched off. The display shows the fan symbol and **OFF**.

2. Recirculation

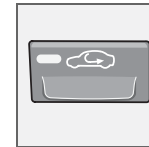

Recirculation can be used to shut out bad air, exhaust fumes, etc. from the passenger compartment. The air in the passenger compartment is recirculated. No outside air is taken into the car when this function is activated. Recirculation (together with the air conditioning system) cools the passenger compartment more quickly in hot weather. If the air in the car recirculates for too long, there is a risk of the windows misting.



Manual climate control, AC

Timer

The timer function minimises the risk of icing, misting and bad air if recirculation is selected. See page 65, for how to activate/deactivate the function. When the Defroster (3) program is selected, recirculation is deactivated.

3. Defroster



Quickly removes misting and ice from the windscreen and side windows. Air flows to the windows at high fan speed. The light in the defroster button illuminates

when the function is active.

The following also takes place when the defroster function is activated in order to provide maximum dehumidification in the passenger compartment:

- the air conditioning (AC) is automatically switched on (can be switched off with the **AC** button (5))
- recirculation is automatically disengaged.

When the defroster is switched off the climate control returns to the previous settings.

4. Air distribution



The airflow can be distributed to the windows, dashboard vents or floor by pressing the air distribution buttons.

A symbol on the display above the climate control panel and an illuminated light in the relevant button indicate which function has been selected.

See the table on p. 78.

5. AC – On/Off

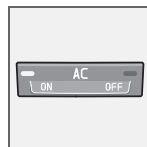

ON: Air conditioning is on. It is controlled by the system's AUTO function. This way, incoming air is cooled and dehumidified.

OFF: Off.

When the defroster function is activated the air conditioning is automatically switched on (can be switched off with the AC button).

6. and 7. Heated front seats

(option in certain markets)



– Higher heat
Press the button once – both lights illuminate.

- Lower heat
Press the button twice – one light illuminates.
- Heat off
Press the button three times – light not illuminated.

8. Rear window and door mirror defrosters

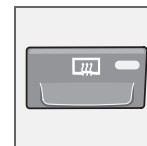

Use the defroster to quickly remove misting and ice from the rear window and door mirrors. The rear window and door mirrors are defrosted simultaneously if

the button is pressed once. The function is active if one lamp is illuminated in the button.

The function is switched off manually or automatically. Switch off manually with one press on the button. Automatic switching off disconnects the rear window and door mirrors after 12-20 minutes depending on outside temperature.

During cold weather the defrosting also continues after 20 minutes in order to keep the rear window and door mirrors free of ice and mist.¹ The intensity of the defrosting can be adapted to the outside temperature. This function must be switched off manually.

¹ Depending on market and selected options



Manual climate control, AC

9. Temperature

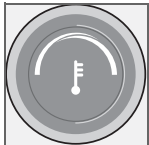

Select cooling or heating for both driver and passenger side.



Electronic climate control, ECC (option)

Control panel

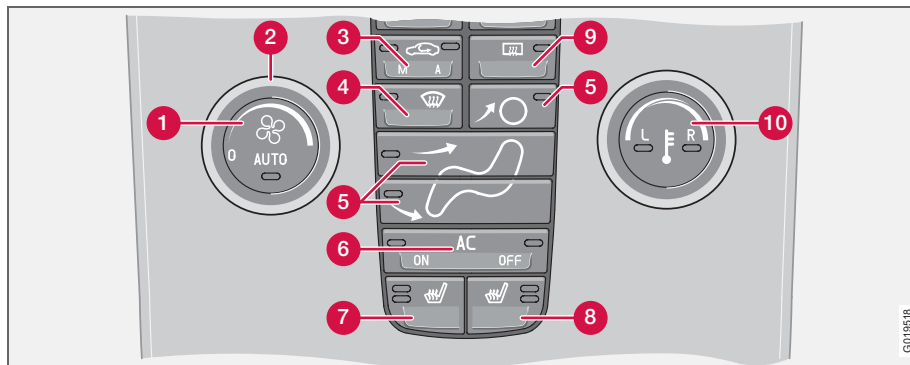

1. **AUTO**
2. Fan
3. Recirculation/Air quality system
4. Defroster
5. Air distribution
6. **AC ON/OFF** – Air conditioning On/Off
7. Heated front left seat
8. Heated front right seat
9. Rear window and door mirror defrosters
10. Temperature selector

Functions

1. AUTO

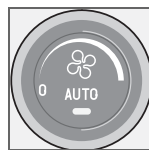

The **AUTO** function automatically regulates climate control and maintains the selected temperature. The AUTO function controls heating, air conditioning, fan speed, recirculation, and air distribution. If you select one or more manual functions, the other functions continue to be controlled automatically. All manual settings are switched off when **AUTO** is switched on. The display shows **AUTO CLIMATE**.

2. Fan

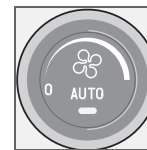

Increase or decrease fan speed by turning the knob. The fan speed is regulated automatically if **AUTO** is selected, and the previously set fan speed is disengaged.

i NOTE

If the knob is turned anticlockwise and the fan indication on the display goes out, the fan and the air conditioning are switched off. The display shows the fan symbol and **OFF**.

Electronic climate control, ECC (option)

3. Recirculation

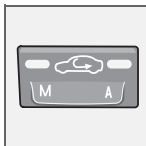

Recirculation can be used to shut out bad air, exhaust fumes, etc. from the passenger compartment. The air in the passenger compartment is recirculated, i.e. no outside air is taken into the car when this function is activated. If the air in the car recirculates for too long, there is a risk of misting on the insides of the windows.

Timer

The timer function minimises the risk of icing, misting and bad air if recirculation is selected. See Personal preferences, page 65, for how to activate/deactivate the function.

NOTE

When Defroster (4) is selected, recirculation is always deactivated.

3. Air quality system (option)

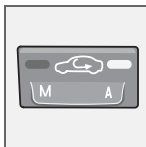

(same button as recirculation)

The air quality system consists of a multi-filter and a sensor. The filter separates gases and particles to

reduce the levels of odours and pollution in the passenger compartment. When the sensor detects polluted outside air, the air intakes are closed and the air in the passenger compartment is recirculated. A green light **(A)** illuminates in the button when the air quality sensor is active.

Activating the air quality sensor:

- Press **AUTO** (1) to activate the air quality sensor (normal setting).
- Or:
- Switch between three functions by pressing repeatedly the recirculation button.
 - Air quality sensor engaged – the light **(A)** illuminates.
 - No recirculation engaged, provided it is not required for cooling in hot weather – light not illuminated.
 - Recirculation engaged – the light **(M)** illuminates.

Keep the following in mind:

- As a rule, the air quality sensor should always be engaged.
- Recirculation is limited in cold weather to avoid misting.
- The defroster functions for the front, side and rear windows can be used to demist the windows.

4. Defroster



Quickly removes misting and ice from the windscreen and side windows. Air flows to the windows at high fan speed. The light in the defroster button illuminates when the function is active.

The following also takes place when the defroster function is activated in order to provide maximum dehumidification in the passenger compartment:

- the air conditioning (AC) is automatically switched on (can be switched off with the **AC** button (5))
- recirculation is automatically disengaged.

When the defroster is switched off the climate control returns to the previous settings.

5. Air distribution

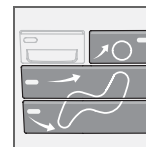

The airflow can be distributed to the windows, dashboard vents or floor by pressing the air distribution buttons.

A symbol on the display above the climate control panel and an illuminated light in the relevant button indicate which function has been selected.

See the table on page 78.



Electronic climate control, ECC (option)

6. AC – On/Off (ON/OFF)

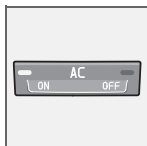

ON: Air conditioning is on. It is controlled by the system's AUTO function. This way, incoming air is cooled and dehumidified.

OFF: Off

When the defroster function is activated the air conditioning is automatically switched on (can be switched off with the **AC** button).

NOTE

The climate control system's demisting function with humidity sensor is significantly reduced with the air conditioning in deactivated mode (**OFF**), as well as with manually selected air distribution and fan speed.

7. and 8. Heated front seats

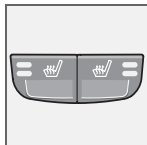

(option in certain markets)

To activate front seat heating:

– Higher heat:
Press the button once – both lights illuminate.

– Lower heat:
Press the button twice – one light illuminates.

– Heat off:
Press the button three times – light not illuminated.

9. Rear window and door mirror defrosters



Use the defroster to quickly remove misting and ice from the rear window and door mirrors. The rear window and door mirrors are defrosted simultaneously if the button is pressed once. The function is active if one lamp is illuminated in the button.

The function is switched off manually or automatically. Switch off manually with one press on the button. Automatic switching off disconnects the rear window and door mirrors after 12-20 minutes depending on outside temperature.

During cold weather the defrosting also continues after 20 minutes in order to keep the rear window and door mirrors free of ice and mist.¹ The intensity of the defrosting can be adapted to the outside temperature. This function must be switched off manually.

¹ Depending on market and selected options

10. Temperature selector

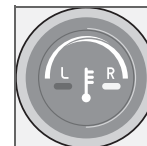

The temperatures on the driver and passenger sides can be set independently.

Press the button once to activate one side. Press again to activate the other side. Press the button a third time to activate both sides.

The active side is indicated by the button's light and in the display above the climate control panel.









When the car is started, the most recent setting is resumed.

NOTE

Heating or cooling cannot be hastened by selecting a higher or lower temperature than the actual desired temperature.



Air distribution

	Air distribution	Use:		Air distribution	Use:
	Air to windows. Some air flows to the dashboard air vents. The air is not recirculated. Air conditioning is always engaged.	to remove ice and misting quickly.		Air to the floor and windows. Some air flows to the dashboard air vents.	to ensure comfortable conditions and good demisting in cold or humid weather.
	Air to windscreen and side windows. Some air flows to the dashboard air vents.	to prevent misting and icing in a cold and humid climate. (Not for low fan speed.)		Air to floor and from dashboard air vents.	in sunny weather with cool outside temperatures.
	Airflow to windows and from dashboard air vents.	to ensure good comfort in warm, dry weather.		Air to the floor. Some air flows to the dashboard air vents and windows.	to warm the feet.
	Airflow to the head and chest from the dashboard air vents.	to ensure efficient cooling in warm weather.		Airflow to windows, from dashboard air vents and to the floor.	to provide cooler air for the feet or warmer air to the upper body in cold weather or hot, dry weather.

03



Fuel-driven heater (option)

General information about heaters

The parking heater can be started immediately or set with two different start times using **TIMER AM** and **TIMER PM**. Here, start time refers to the time the car is heated and ready. The car's electronic system calculates when heating should be started based on the outside temperature. The heater is not run if the outside temperature exceeds 25 °C. At minus 10 °C and below, the maximum running time of the parking heater is 60 minutes.

Parking on a hill

If the car is parked on a steep hill, the front of the car should point downhill to ensure that there is a supply of fuel to the parking heater.

WARNING

The car must be outdoors when the petrol or diesel heater is used.

WARNING

Switch off the fuel-driven heater before refuelling. Spilled fuel could be ignited.

Check on the information display that the heater is off. When the additional heater is running, **PARK HEAT ON** is shown on the information display.



Warning decal on fuel filler flap

Activating the heater

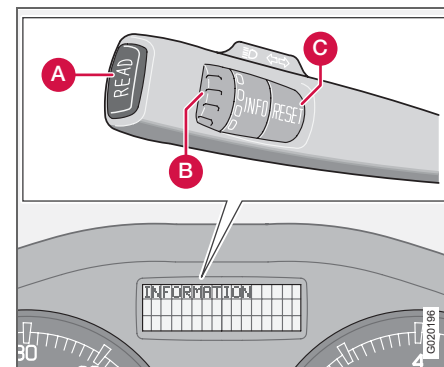

- Enter the time when the car is to be used. Press **RESET** (C) to enter the hours and minutes.
- Press and hold the **RESET** (C) button until the timer is activated.

Direct start

- Use the thumbwheel (B) to scroll to **DIRECT START**.
- Press **RESET** (C) to access the options **ON** and **OFF**.
- Select **ON**. The heater will now run for 60 minutes. Heating of the passenger compartment will begin as soon as the engine coolant has reached a temperature of 30 °C.



Fuel-driven heater (option)

Immediate stop of heater

- Use the thumbwheel (B) to scroll to **DIRECT START**.
- Press **RESET** (C) to access the options **ON** and **OFF**.
- Select **OFF**.

NOTE

The car can be started and driven while the parking heater is still running.

Battery and fuel

If the battery has insufficient charge or the fuel level is too low, the parking heater will be switched off automatically. A message appears on the information display. Acknowledge the message by pressing **READ** once (A).

IMPORTANT

Repeated use of the parking heater combined with short journeys may discharge the battery and impair starting. If the heater is used regularly, the car must be driven for the same as the heater is run to ensure that the alternator has time to charge the battery.

Setting the **TIMER AM** and **PM**

For safety reasons, you can only programme times for the following 24 hours, not several days in advance.

- Scroll with the thumbwheel to **TIMER**.
- Touch **RESET** to move to the flashing hours setting.
- Scroll with the thumbwheel to the desired hour.
- Touch **RESET** to move to the flashing minutes setting.
- Scroll with the thumbwheel to the desired minute.
- Touch **RESET** to confirm the setting.
- Press **RESET** to activate the timer. After setting **TIMER AM**, a second start time can be programmed with **TIMER PM**. Access this with the thumbwheel. Set the alternative start time in the same way as **TIMER AM**.

Messages on the display

When **TIMER AM**, **TIMER PM** and **DIRECT START** are activated, the information symbol on the combined instrument panel illuminates and an explanatory text appears on the information display. The display also indicates which **TIMER** is active when the driver removes the key from the ignition to leave the car.

Clock/timer

If the car clock is reset after the heater timers are programmed, the selected times will be cancelled.

Additional heater (diesel)

(certain countries)

Extra heat from the additional heater may be required in cold weather to reach the correct temperature in the passenger compartment.

The additional heater starts automatically when extra heat is required if the engine is running. It is switched off automatically when the correct temperature is reached or when the engine is switched off.



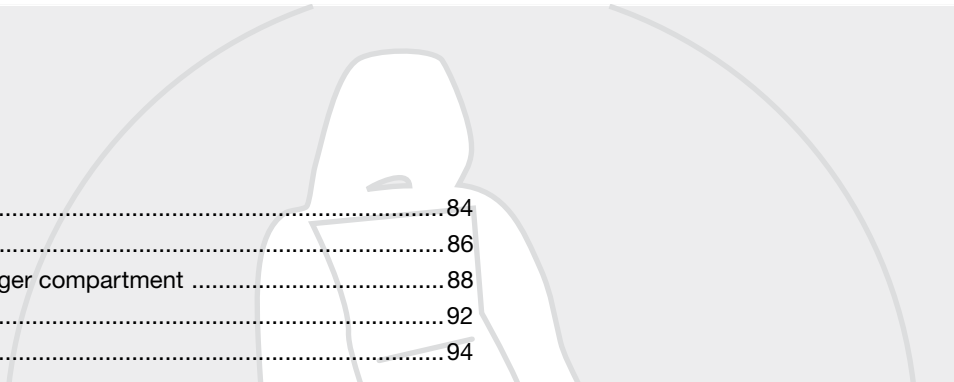

Front seats	84
Interior lighting	86
Storage spaces in the passenger compartment	88
Rear seat	92
Cargo area	94

INTERIOR



04



Front seats

Seating position



The driver's and passenger seats can be adjusted to the optimum sitting and driving positions

1. Forward/backward: lift the handle to adjust the distance to the steering wheel and pedals. Check that the seat is locked after changing position
2. Raise/lower the front of the seat cushion, pump up/down, (option on passenger side)
3. Raise/lower the seat, pump up/down, (option on passenger side)
4. Lumbar support¹, turn the wheel, (option on passenger side)

¹ Also applies to power seat.

5. Backrest rake: turn the wheel
6. Control panel for power seat (option).

WARNING

Adjust the position of the driver's seat before setting off, see page 12, never while driving.

Check that the seat is locked in position.

Lowering the front seat backrest (option)

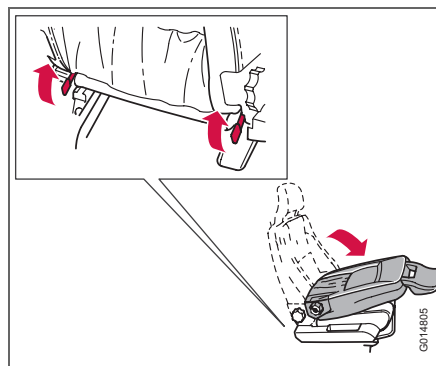

The passenger seat backrest can be folded forward to make room for long loads.

- Move the seat as far back as possible.
- Adjust the backrest to an upright position 90 degrees.

- Lift the catches on the rear of the backrest while folding it forwards.
- Push the seat forward so that the head restraint "locks" in under the glovebox.

Floor mats (option)

Volvo supplies floor carpets which are especially produced for your car.

WARNING

The floor mat at the driver's seat must be firmly fitted and secured in the attachment clips to prevent it from being trapped around and under the pedals.



Front seats

Power seat (option)

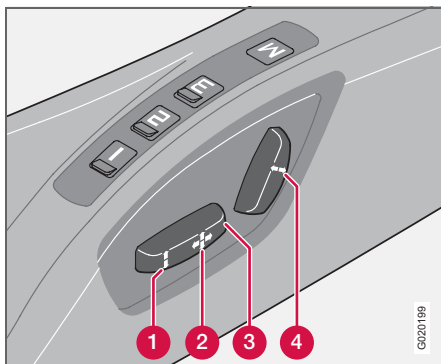

The seats can be adjusted for a certain time after unlocking the door with the remote control, without the key being inserted into the ignition switch. The seat can always be set in ignition position I or II.

1. Front edge of seat cushion up/down
2. Seat, forwards/backwards
3. Seat, up/down
4. Backrest rake

Overload protection is deployed if any seat is blocked. If this occurs, switch off the ignition and wait a short time before operating the seat again. Only one of the seat's settings can be adjusted at a time.

Memory function

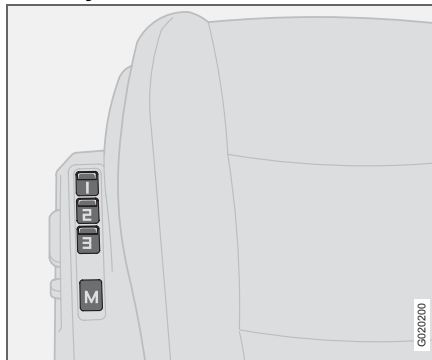

Buttons for memory function

Store setting

- Adjust seat.
- Press and hold button **M** while pressing button **1**, **2** or **3** simultaneously.

Using a stored setting

Press one of the memory buttons **1** – **3** until the seat stops. If you release the button then the movement of the seat will stop.

Emergency stop

If the seat accidentally begins to move, press any of the buttons to stop the function.



WARNING

Risk of crushing. Make sure that children do not play with the controls. Check that there are no objects in front of, behind or under the seat during adjustment. Ensure that none of the rear seat passengers can be trapped.

Key memory in remote control key

The driver's seat settings are stored in the key memory when the car has been locked with the remote control key. When the car is unlocked with the same remote control key the driver's seat adopts the stored settings when the driver's door is opened.



NOTE

The key memory is independent of the seat memory.



Interior lighting

Reading lamps and interior lighting

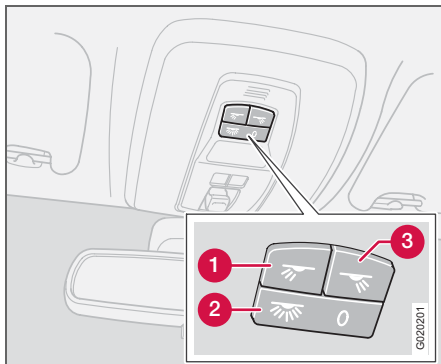

Passenger compartment lighting and reading lamps

1. Reading lamp left-hand, On/Off
2. Passenger compartment lighting front and rear
3. Reading lamp right-hand, On/Off

Switch (2) has three positions for the interior lighting:

- Off (0) – right-hand side depressed, automatic lighting off.
- Neutral position – interior lighting comes on when a door is opened and goes out when the door is closed. The dimmer function is active.
- On – left-hand side depressed, passenger compartment lighting on.

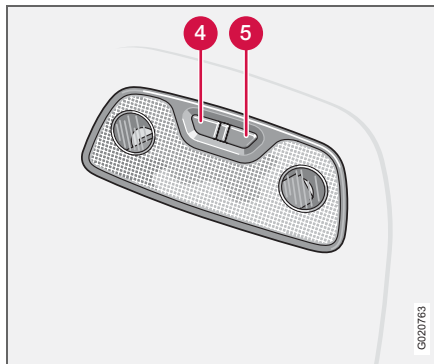

Reading lamps, rear

4. Reading lamp left-hand rear, On/Off
5. Reading lamp right-hand rear, On/Off

The reading lamps can be switched on in ignition position I and II as well as when the engine is running. They can also be activated within 30 minutes after the engine has been switched off or when one of the doors has been opened/closed.

Cargo area lighting

Interior and cargo area lighting are switched on when the tailgate is opened and remain on for 5 minutes.

The lighting switches off:

- if the tailgate is closed
- if switch (2) is set to the Off position.

Automatic lighting

The passenger compartment lighting is switched on and off automatically when button (2) is in neutral position.

The passenger compartment lighting is switched on and remains on for 30 seconds if:

- the car is unlocked from the outside with the key or remote control
- the engine is stopped and the ignition key is turned to position 0

The passenger compartment lighting is switched off when:

- the engine is started
- the car is locked from the outside with the key or remote control

The passenger compartment lighting comes on and remains on for 5 minutes if one of the doors is open.



Interior lighting

The passenger compartment lighting can be switched on or off with button (2) within 30 minutes, from the time that the key is turned to position 0, and it then remains on for 5 minutes if it is not switched off.

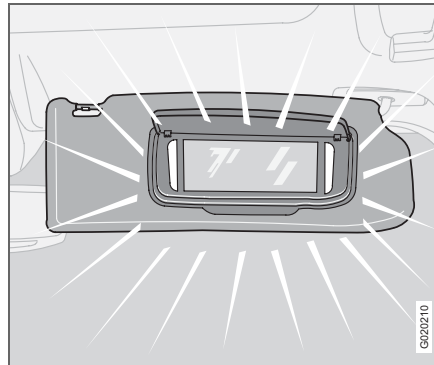
Vanity mirror¹

The light illuminates automatically when the cover is lifted.

¹Option on certain markets



Storage spaces in the passenger compartment

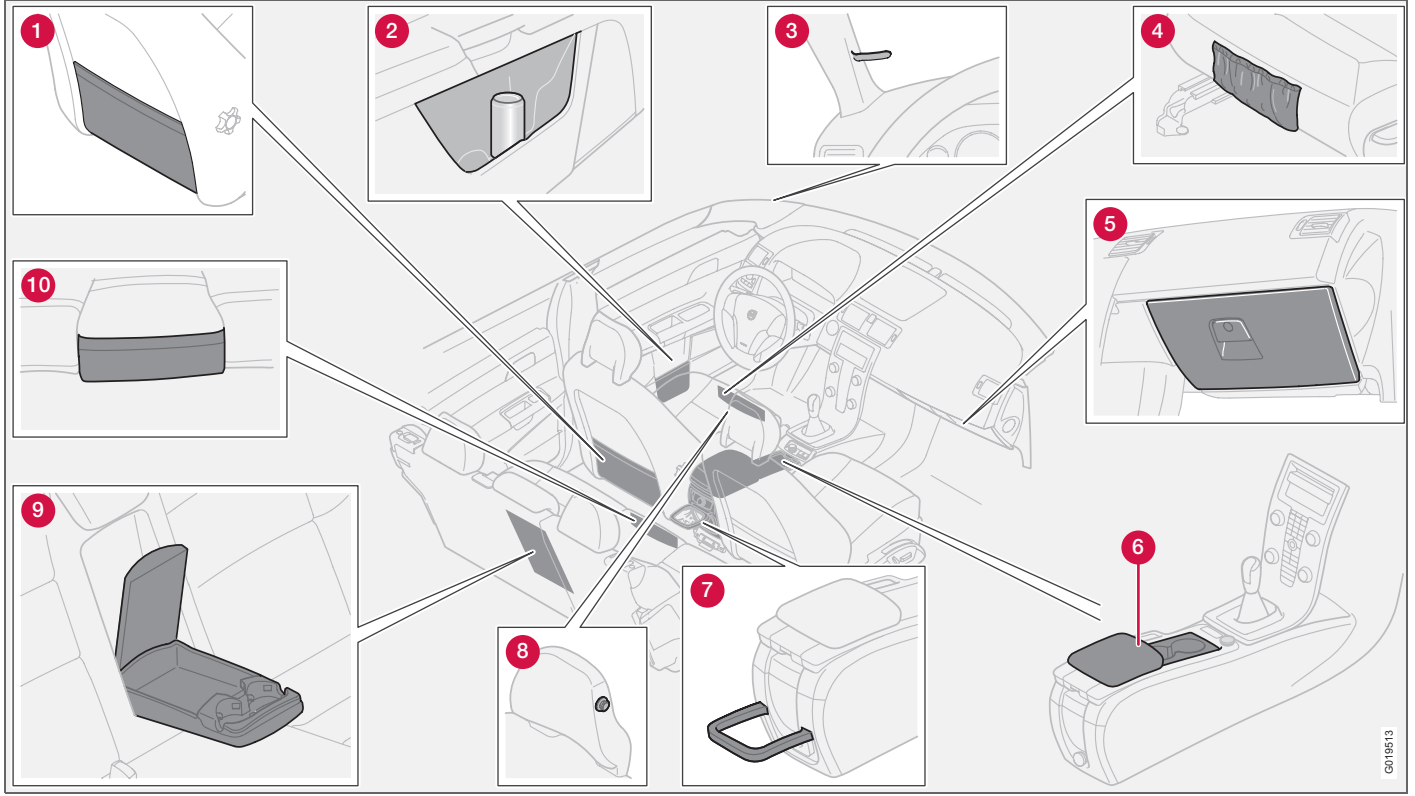

04

GM19513



Storage spaces in the passenger compartment

Storage spaces

1. Storage pocket on rear of front seats.
2. Storage compartment in door panel with cup holder and holder for ice scraper.
3. Ticket clip
4. Storage pocket on front edge of front seat cushions.
5. Glovebox
6. Storage compartment (e.g. for CD discs) and cup holder¹
7. Bottle holder (option)
8. Coat hanger, only for light garments.
9. Storage compartment and cup holder
10. Storage pocket on front edge of centre rear seat cushion (option).



WARNING

Ensure that no hard, sharp or heavy objects lie or protrude in such a way that they could cause injury during heavy braking.

Always secure large and heavy objects with a seatbelt or cargo retaining straps.

¹ Storage compartment, in certain markets

Glovebox

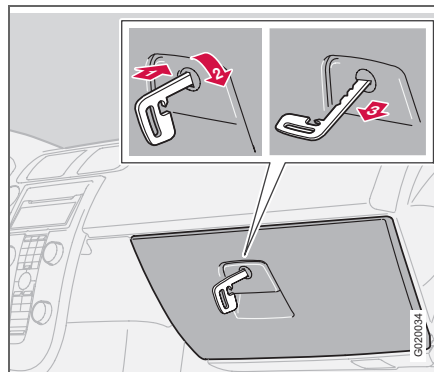

The owner's manual and maps can be kept here. There are also holders for coins, pens and fuel cards. The glovebox can be locked with the remote control's detachable key blade. For further information on the key blade, see page 101.

Locking the glovebox:

1. Insert the key blade into the keyhole.
2. Turn the key a quarter of a turn (90 degrees) clockwise.
3. Remove the key. The keyhole is horizontal in the locked position.

To unlock the glovebox, carry out the above in reverse order.

Coat hanger

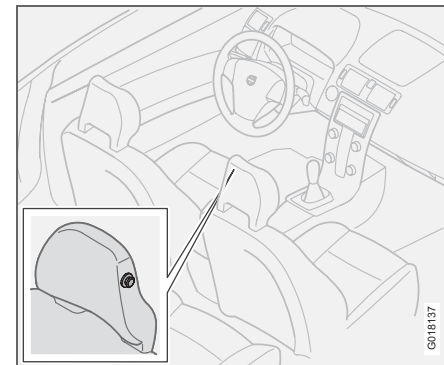

The coat hanger is located on the passenger seat head restraint. Only hang light garments on the hanger.



Storage spaces in the passenger compartment

Holder for ice scraper

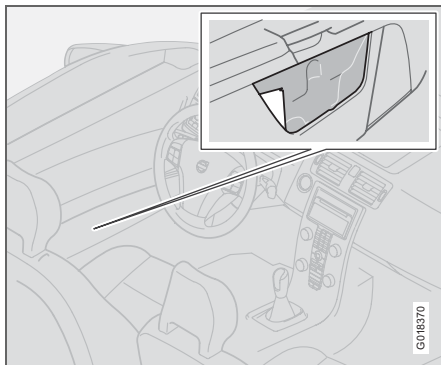

In the front door storage compartments, in the rear section, is an integrated holder for an ice scraper. Insert the ice scraper into the holder. The ice scraper must be the type with a rectangular plastic section, approx. 3 mm thick. In front of the ice scraper is a space for a soda can.

Storage under the front armrest

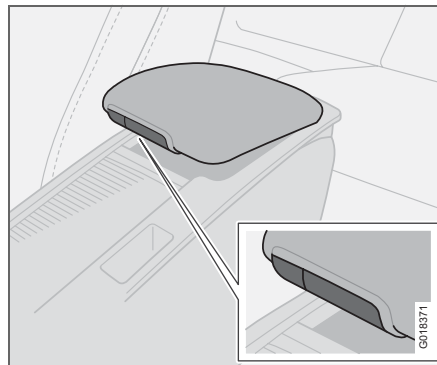

There is a storage space under the armrest. There is also a smaller storage space in the detachable armrest. Press the small button and lift the armrest to open the shallow compartment. Press the large button and lift the armrest to open the deeper compartment.

Cup holder in centre console

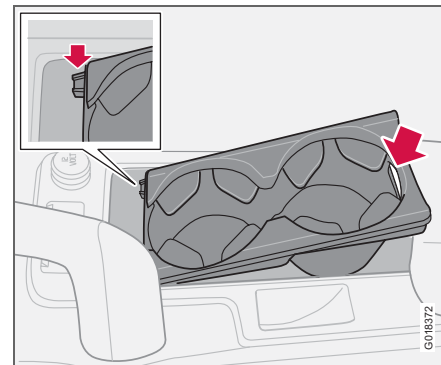

There is space for a double cup holder under the roller cover. The space can be used for storage by lifting out the cup holder. Lift at the rear edge of the cup holder where there is a recess.

If the cup holder is being fitted - first align its two guide lugs in the two recesses in the front edge of the space and then press down the rear edge of the cup holder.

Close the roller cover by gripping its front edge from below and pulling forward.



Storage spaces in the passenger compartment

Storage compartment behind the gear lever

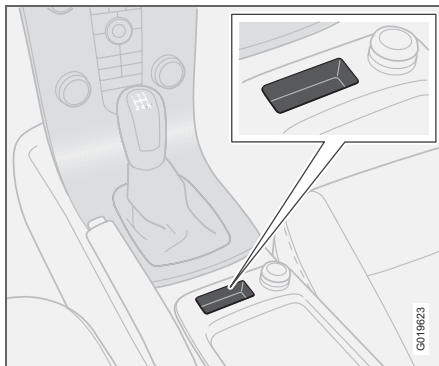

When there are no buttons for parking assistance and BLIS, see page 136 and page 138, the space can be used as a storage compartment.

Bottle holder (option)

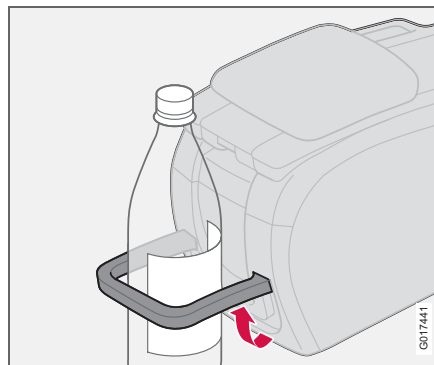

A bottle holder for larger bottles is located on the rear of the tunnel console.

Ashtray (option)

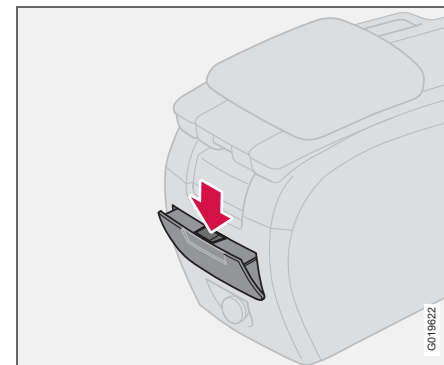

An ashtray is located towards the rear of the tunnel console.

Open the ashtray by pulling the top edge of the cover.

Emptying the ashtray:

1. Press in the catch, see illustration, and tilt the cover up.
2. Then lift the ashtray out.



Rear seat

Head restraint, rear

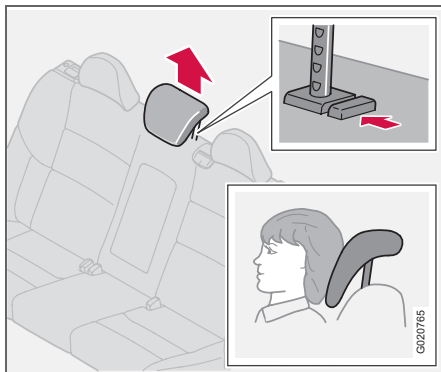

All head restraints can be adjusted vertically to suit the height of the passenger. The upper edge of the head restraint should be aligned with middle of the back of the head. Raise the head restraint as necessary. To lower the head restraint, press the button by the right-hand pillar at the same time as pushing down the head restraint. To remove the head restraint, press the button by the right-hand pillar while lifting out the head restraint.

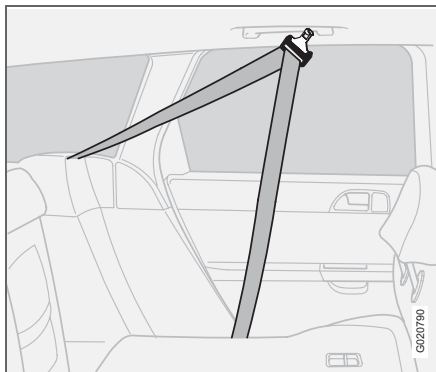

Tipping the rear seat backrest

The rear seat backrests can be tipped forwards together, or individually, to make it easier to transport long objects. To avoid damaging the seatbelts when folding the backrests up or down, these should be hooked onto the grab handles.

- Hang the seatbelts on the hooks before lowering or raising the backrests.
- Lift the rear edge of the seat cushion (1) to fold the seat cushions forward.

IMPORTANT

The head restraints could be damaged if they are not removed for loading. The head restraint in the centre must also be removed for heavy loads.



Rear seat

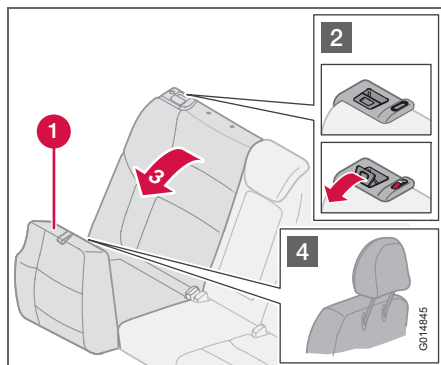

Lowering the backrest

- Pull the lock (2) catch up and forward to release the backrest. A red indicator on the lock catch shows that the backrest is no longer locked in place.
- Fold the backrests (3) forward halfway and remove the head restraints on the outside seats. The centre seat's head restraint must be removed for a fully level floor.
- Place the head restraints in the plastic sleeves on the undersides (4) of the raised seat cushions.

i NOTE

When the backrest has been raised, the red indicator should no longer be showing. If it is, the backrest is not locked in place.

⚠ WARNING

Remember to take down the seatbelts once you have raised the backrest.



Cargo area

Safety grille (option)

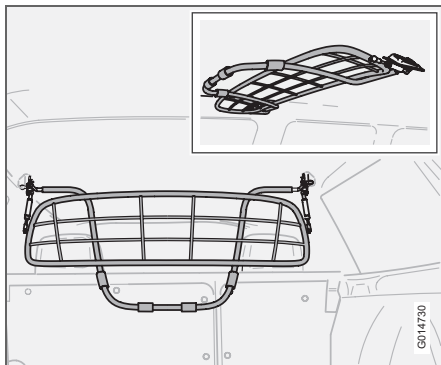

The safety grille is designed to help prevent loads or pets from being thrown forward in the passenger compartment in the event of sudden braking. For safety reasons, the grille must always be correctly fastened and secured.

Folding up

If the safety grille is in the way it can be folded up to the roof:

- Take hold of the bottom of the safety grille.
- Pull straight backward and upward. Then release. The gas struts prevent the grille from dropping down.

To fold down the grille, do the reverse.

Removing

Remove the safety grille as follows:

- Fold the rear seat backrest forward slightly (to relieve the load from the gas struts).
- Remove the caps from the nuts on either side that secure the safety grille.
- Unscrew the nuts until the threads are flush with the edge of the nuts.
- Turn the grille backward in the car slightly to release it from the trim. Do not angle the grille too much as it can become wedged, making it difficult to pull out.
- Repeat for the other mounting and then carefully lift the grille out of the car.

Fitting

To fit the safety grille:

- Follow the instructions in the reverse order.
- Tighten the two nuts to 24 Nm.

If unsure about installing or removing the safety grille, consult an authorised Volvo workshop.

Cargo cover (option)

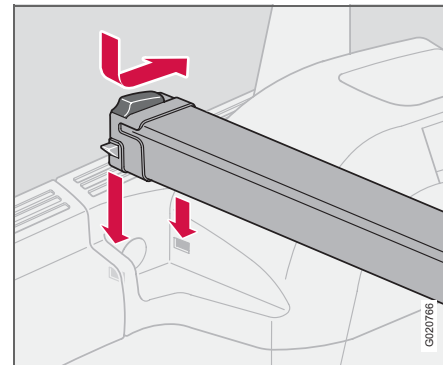

Cargo cover

Fitting the cargo cover.

Fit the cargo cover as follows:

- Move the front section of the cargo cover backwards/over the cassette.
- Following which, fit the cargo cover in its tracks along the side panels, furthest into the cargo area.
- Push the button forward so that the catches are retracted. Following which, press the cargo cover down in the track.
- The button springs back when the cargo cover is correctly located.
- Repeat the procedure on the opposite side.



Cargo area

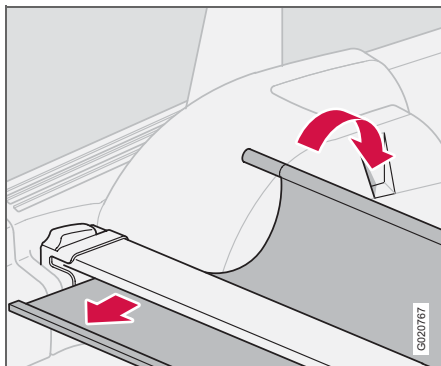

- Check that the cargo cover is fitted firmly in the cargo area.
- Fit the front section of the cargo cover in the wedge shaped tracks on the side panels, against the rear seat.
- The cargo cover is now ready for use.

WARNING

Do not place objects on the cargo cover or on its front section.

Use

Pull the cargo cover over the cargo area and hook it into the tracks in the cargo area's rear pillars.

Removing the cargo cover

- Lift up the front section of the cargo cover, move it backwards and then allow it to hang free.
- Move the button forwards, lift up one end of the cargo cover. Repeat on the opposite side. Following which, pull out the cargo cover.

Different variants

Cars with the cargo cover option are either equipped with type A or type B.

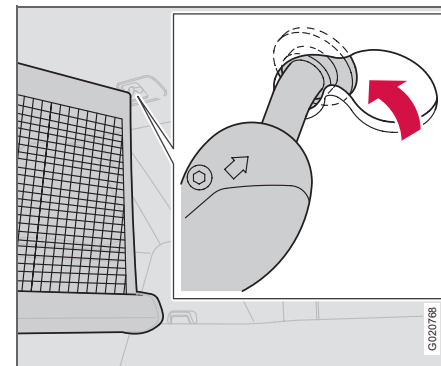
Safety net

The retractable safety net¹ storage cassette is mounted on the back of the rear seat backrest.

Using the safety net with raised backrests

- Pull out the safety net horizontally backward. Extend the right hand attachment and hold it extended. Insert the attachment into the rear keyed recess in the roof panel. Press the attachment forward in the keyway. The attachment must be pressed so far that the flange rides over the restriction between the front and rear holes.

¹ Option on certain markets



Cargo area

- Perform the same procedure on the other side. The attachments on the net spring shut. Pull the net over towards the left bracket to fit it in place.
- Check that the attachments on the safety net are securely fastened in the keyed recesses in the roof panel.

Using the safety net with lowered backrests

The safety net can also be used when the backrests are lowered. In this case, use the front attachment points in the roof panel.

Removing the safety net

- Pull one of the net's attachments rearward to the large hole and pull it out.
- Detach the other attachment in the same way.

Removing the safety net storage cassette

- Lower the entire backrest.
- Press the cassette outward to release it from the mounting brackets.



WARNING

Loads in the cargo area must be firmly secured even if the safety net is correctly fitted.

Using the safety net together with the cargo cover

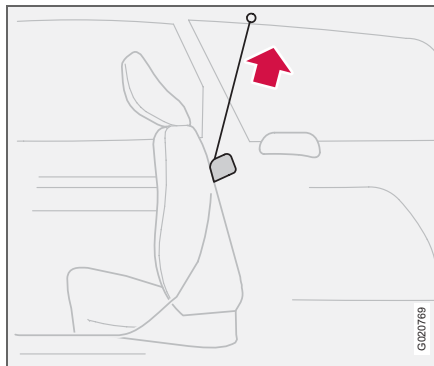

- Tip the backrests slightly forward to access the safety net cassette. Start with the 40 % section.
- Extend the safety net rearward.
- Fold the backrests back up.
- Hook the net into the attachment points in the roof panel as described for raised backrests.



NOTE

When the backrest has been raised, the red indicator should no longer be showing. If it is, the backrest is not locked in place.

Load retaining eyelets

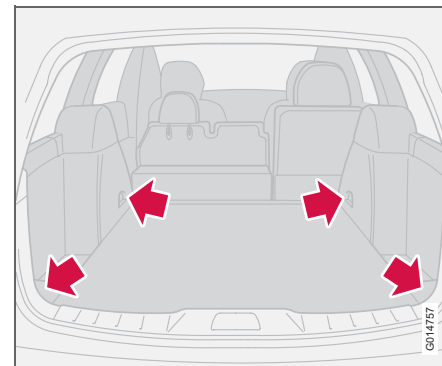

The load retaining eyelets¹ are used to fasten straps or nets to anchor items in the cargo area.

¹ Option in certain markets



Electrical socket in cargo area (option)

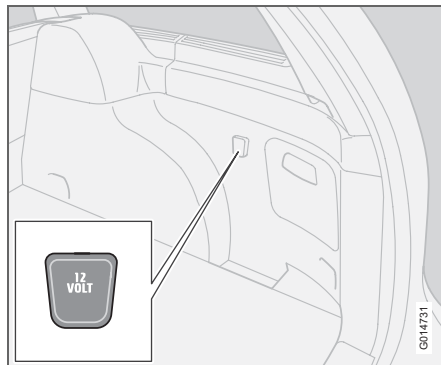

Fold down the cover to access the electrical socket. This socket works regardless of whether or not the ignition is on.

Remember to avoid using the electrical socket with the ignition switched off due to the risk of discharging the battery.

Bag holder (option)

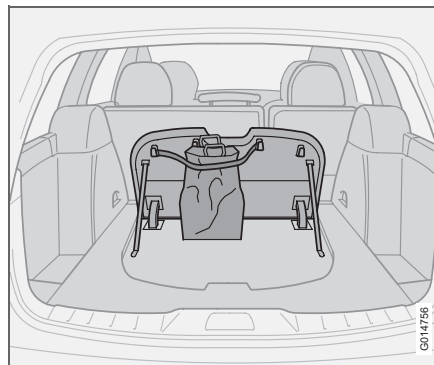

The bag holder holds shopping bags in place and prevents them tipping over and spilling their contents.

- Open the hatch in the cargo area.
- Secure the shopping bags with the strap.

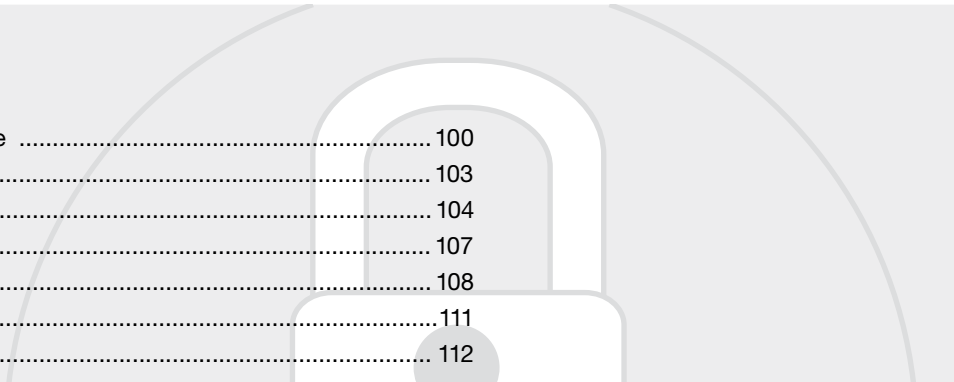

Remote control with key blade	100
Active locks	103
Keyless drive (option)	104
Battery in remote control	107
Locking and unlocking	108
Child safety locks	111
Alarm (option)	112

LOCKS AND ALARM



05



Remote control with key blade

Remote control

The car is supplied with two remote controls which also serve as ignition keys. The remote controls contain detachable metal key blades for mechanical locking/unlocking of the driver's door and glovebox.

The key blades' unique code is available at authorised Volvo workshops, who can order new key blades.

A maximum of six remote controls/key blades can be programmed and used for one single car.

Turn signal indication during locking/unlocking

When the car is unlocked using the Keyless Drive system or the remote control, two short flashes of the direction indicators serve to indicate that unlocking was correctly performed.

For locking, the indication takes place with one long flash and only if all locks have been locked, after the doors and the tailgate have been closed.

Personal preferences can be used to deactivate indication via the direction indicators. There will then be no visual indication as to whether the lock status is correct. See page 66.

Loss of a remote control

If you lose a remote control, take the car and the other remote controls to an authorised Volvo workshop. The code of the missing remote control must be erased from the system as a theft prevention measure.

Immobiliser

The remote controls are fitted with coded chips. The code must be accepted by the reader (receiver) in the ignition switch. The car can only be started if the correct remote control with the correct code is used.

Remote control functions

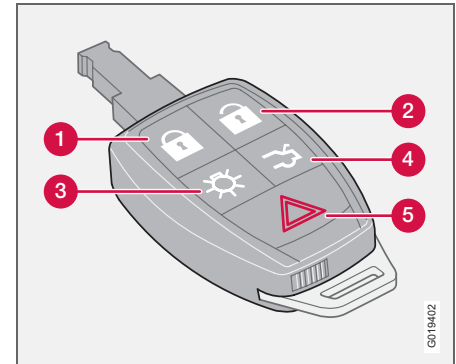

1. Locking — Locks all doors and the tailgate. Press and hold to close the side windows and sunroof.
2. Unlocking — Unlocks the doors and the tailgate. Press and hold to open the side windows.
3. Approach lighting — When you approach the car: Press the yellow button on the remote control to switch on the interior lighting, position/parking lamps, number plate lighting and door mirror lamps (option). The lighting is switched off automatically after 30, 60 or 90 seconds. For information on setting the delay time, see page 66.



Remote control with key blade

4. Tailgate — Press the button once to unlock the tailgate only.

NOTE

The function does not open the tailgate.

5. Panic function — Used to attract attention in an emergency. Press and hold the red button for at least three seconds or press it twice within three seconds to activate the direction indicators and the horn. The function can be turned off with the same button once it has been active for at least 5 seconds. Otherwise the function switches off automatically after 30 seconds.

IMPORTANT

The narrow section of the remote control is particularly sensitive - this contains the chip. The car cannot be started if the chip is damaged.

Detachable key blade

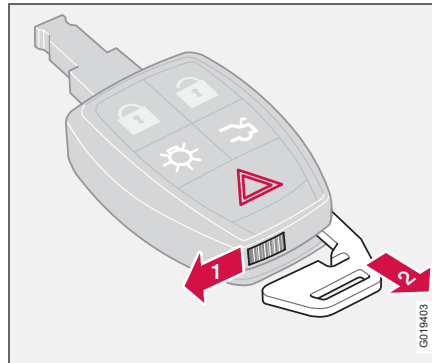

Using the remote control's detachable key blade:

- the driver's door can be opened manually if central locking is not activated with the remote control, see page 102 and page 105.
- access to the glovebox can be blocked, see page 102.

Removing the key blade

To take the key blade out of the remote control:

- Slide the spring-loaded catch (1) to the side while pulling the key blade (2) out.

Inserting the key blade

Be careful when inserting the key blade into the remote control.

- Hold the remote control with the narrow end pointing down and lower the key blade into its slot.
- Lightly press the key blade to lock it in position. You should hear a "click".



Remote control with key blade

Unlocking doors with the key blade

If central locking cannot be activated with the remote control, e.g. if the batteries are discharged, then the driver's door can be unlocked and opened as follows:

- Insert the key blade in the driver's door keyhole.
- Turn the blade 45 degrees clockwise and open the door.

i NOTE

When the driver's door is unlocked using the key blade and is opened, the alarm is triggered. It is deactivated by inserting the remote control in the ignition switch. See page 113.

Locking the glovebox

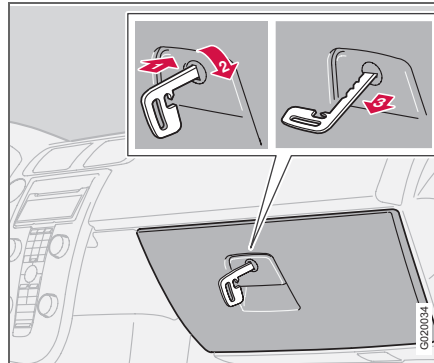

The glovebox can only be locked/unlocked using the remote control's detachable key blade. For information on removing the key blade, see page 101.

- Lock the glovebox by turning the key a quarter of a turn (90 degrees) clockwise. The keyhole is horizontal in the locked position.

i NOTE

The remote control cannot be used to open the glovebox without the key blade. This function is particularly useful for when the car is left for service, at a hotel or similar.

- Unlock by carrying this out in reverse order. The keyhole is vertical in the unlocked position.



Active locks

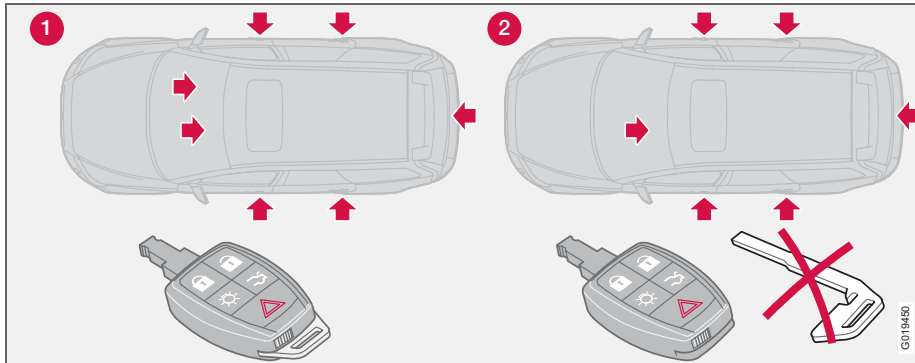

1. Active locks for remote control with key blade.
2. Active locks for remote control without key blade.



Keyless drive (option)

Keyless lock and ignition system

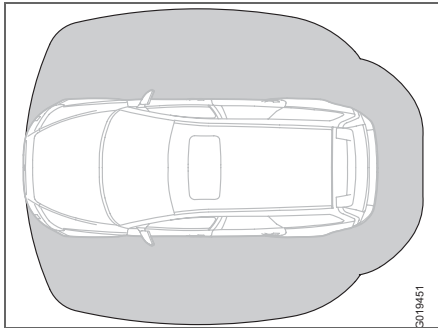

Keyless function range

The keyless drive system allows the car to be unlocked, driven and locked without the need for a key. You simply need to have the remote control with you in a pocket or a bag.

The system makes it easier and more convenient to open the car, for example with shopping bags in one hand and a child in the other. It saves you having to take out or look for the remote control.

The two remote controls incorporate the keyless drive feature. You can order additional remote controls. The keyless drive system can handle up to six remote controls.

Remote control max. 1.5 m from the car

In order to open a door or the tailgate, a remote control must be no more than approx. 1.5 m from the car door handle or tailgate.

This means that the person who wishes to open a door must have the remote control with him or her. It is not possible to open a door if the remote control is on the other side of the car.

The grey area in the illustration indicates the range covered by the system's antennas.

If someone leaves the car and takes a keyless drive remote control with them, a warning message appears on the information display and a reminder signal sounds. The warning message disappears when the remote control is brought back to the car or when the ignition dial is turned to position **0**. The warning is only issued if the ignition dial is in position **I** or **II** after someone has opened and closed a door.

The warning message and reminder signal disappear when the remote control is brought back to the car after one of the following actions:

- a door has been opened and closed
- the ignition dial has been turned to position **0**
- the **READ** button has been pressed.

Never leave any remote control in the car

If a remote control with keyless drive function is left in the car, it is made passive when the car is locked. This prevents unauthorised entry.

If someone breaks into the car and finds the remote control, it can be activated and used again. It is therefore important to handle all remote controls with care.

Interference to remote control function

Electromagnetic screening and fields can interfere with the keyless drive system. To avoid this: do not place the remote control near mobile phones, metallic objects or, for example, in a metal briefcase.

If interference is experienced nonetheless, use the remote control and key blade in the normal way. See page 100.



Keyless drive (option)

Locking

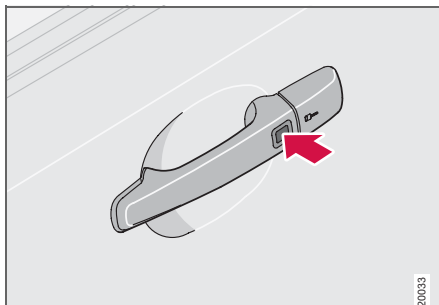

Cars with the keyless system have a button on the outside door handles.

When the remote control is within the range covered by the system's antennas, the doors and the tailgate are locked as follows:

- Push in the lock button on one of the door handles.

All doors must be closed before the lock button is pushed in. Otherwise they will not lock.

When the car is locked, the lock buttons on the inside of the doors retract.

NOTE

On cars with the keyless drive system and automatic transmission the gear selector must be moved to the **P** position and the ignition dial turned to the **0** position. Otherwise the car cannot be locked or alarmed.

Unlocking

When the remote control is within the range covered by the system's antennas:

- Open the doors by pulling the relevant handle.
- Open the tailgate by pressing under the tailgate opening button and lift the tailgate.

If for some reason the keyless drive function in the remote control is not operating, the car can be unlocked using the remote control functions, see page 100.

Power seat (option) – remote control with memory function

If several people with keyless drive remote controls get into the car, then the driver's seat will be adjusted for the person who opens the door first.

Unlocking doors with the key blade

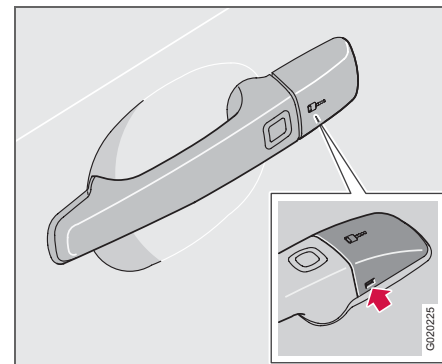

If central locking cannot be activated with the remote control, e.g. if the batteries are discharged, then the driver's door can be opened as follows:

- To access the keyhole:
Carefully prise off the plastic cover on the handle by inserting the key blade into the hole on the underside of the plastic cover.
- Unlock the door using the key blade.

NOTE

When the driver's door is unlocked using the key blade and is opened, the alarm is triggered. It is deactivated by inserting the remote control in the ignition switch. See page 113.



Keyless drive (option)

Antenna location

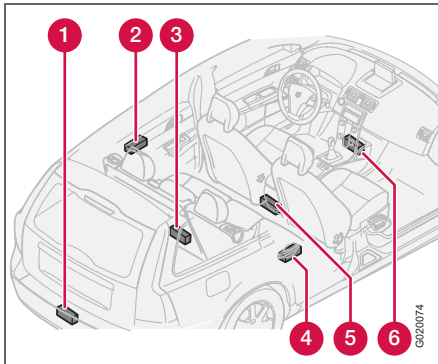

The keyless system has a number of integrated antennae located around the car:

1. Rear bumper, inside centre
2. Door handle, left-hand rear
3. Cargo area, central and furthest in under the floor
4. Door handle, right-hand rear
5. Centre console, under the rear section
6. Centre console, under the front section



WARNING

People with pacemaker operations should not come closer than 22 cm to the keyless system's antennae with their pacemaker. This is to prevent disturbances between the pacemaker and the keyless system.

Personal preferences

The Keyless Drive system can have personal preferences applied, see page 66.



Battery in remote control

Weak remote control battery

When the battery runs down and full functionality cannot be guaranteed, the information symbol and **REMOTE BATTERY LOW VOLTAGE** appear on the display.

Replacing the remote control battery

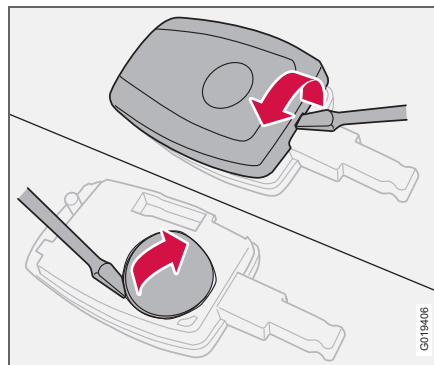

Dispose of the old battery in an environmentally-responsible manner.

If the locks repeatedly fail to respond to signals from the remote control at a normal distance, the battery should be replaced (type CR 2450, 3 V).

- Place the remote control with the keypad downward and prise up the cover using a small screwdriver.
- Remove the cover.
- Carefully examine how the battery's + and - sides are fitted (there is a diagram under the cover).
- Prise away and replace the battery. Avoid touching the battery and its terminals with your fingers.
- Refit the cover and press it in.



Locking and unlocking

Locking/unlocking the car from outside

For cars with the keyless system, see page 104.

Unlocking

The remote control unlock button can unlock the car in two different ways (select option in personal preferences, see page 66):

- one press unlocks the doors and the tailgate
- one press unlocks the driver's door and a second press unlocks the other doors and the tailgate.

Locking

The remote control locks the doors and the tailgate simultaneously. The door lock buttons and inside handles are disengaged¹.

The fuel filler flap cannot be opened if the car is locked with the remote control.



NOTE

The car can be locked even if a door or the tailgate is open. When the door is closed there is a risk that the keys will be locked in. (Applies to certain markets.)

¹ Applies to certain markets



WARNING

Be aware that you can be locked in the car if it is locked from the outside with the remote control. You cannot leave the car using any of the controls inside the car.

Global opening

One long press on the unlock or lock button opens or closes all windows simultaneously (also closes the sunroof).

The function can be used to quickly air the car in hot weather for example.

Different personal settings can be made, see page 66.

Tailgate

Unlocking

Unlocking tailgate only:

- Press the remote control button to unlock the tailgate.

Locking

If the doors are locked when the tailgate is closed then it remains unlocked. Lock with the remote control or from inside to lock the both doors and the tailgate.

Automatic relocking

If none of the doors or the tailgate is opened within two minutes of unlocking, all are locked again automatically (does not apply to locking from inside). This function prevents the car from being left unlocked unintentionally. For cars with alarms, see page 112.



Locking and unlocking

Locking/unlocking the car from inside

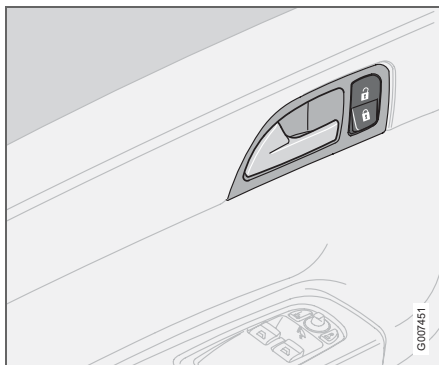

The doors and the tailgate can be locked or unlocked simultaneously using the lock button by the door handle.

Unlocking

- Press the upper section of the lock button. Press and hold to also open all side windows.

The door cannot be unlocked by pulling up the lock button.

Locking

- Press the lower section of the lock button. Press and hold to also close all windows and the tailgate.

All doors can be locked with each respective door's lock button.

Opening the doors

When the doors are locked from the inside:

- Pull the handle twice to unlock and open the doors.

Automatic locking

When the speed of the car exceeds 7 km/h the doors and tailgate can be locked automatically.

When the function is activated and the doors have been locked they can be opened in two ways:

- pull one of the door handles twice
- press the unlock button by the door handle.

The function can be activated/deactivated by means of personal preferences, see page 66.



Locking and unlocking

Deadlocks

When deadlocked, the doors cannot be opened from the inside if they are locked.

The deadlocks are activated with the remote control and are set after a 25 second delay after the doors have been locked.

The car can only be unlocked from a deadlock state with the remote control. The doors can also be opened from the outside with the key.

Temporary deactivation

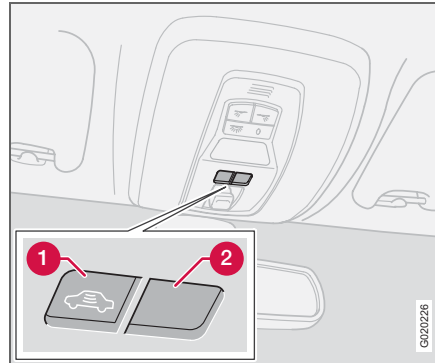

1. Deactivation of the deadlocks and detectors
2. No function

If someone is going to stay in the car but the doors must be locked from the outside, then the deadlocks function can be temporarily deactivated as follows:

- Insert the key into the ignition switch, turn it to position **II** and then back to position **I** or **0**.
- Press button (1).

If the car is equipped with an alarm with movement and tilt detectors, then these are also deactivated at the same time, see page 114.

The light in the button is illuminated until the car is locked with the key or the remote control.



NOTE

If the car is equipped with an alarm: Remember that the car's alarm is armed when the car is locked. If any of the doors are opened from the inside then the alarm will be triggered.

A message remains on the display as long as the key is in the ignition switch.

The detectors are reactivated and deadlocks re-engaged the next time the car is started.



WARNING

Do not allow anyone to remain in the car without first deactivating the deadlocks to avoid the risk of anyone being locked in.



Child safety locks

Manual child locks rear doors

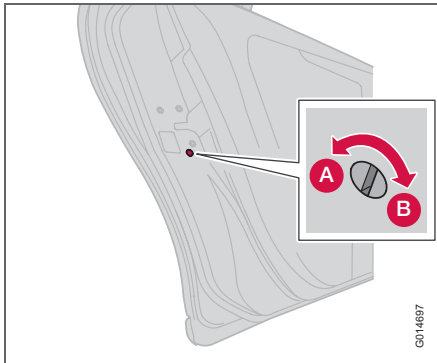

Manual child lock in left-hand rear door

The child safety lock controls are found on the trailing edge of the rear doors and are only accessible when the doors are open.

To activate or deactivate the child safety locks:

1. Remove the remote control key blade.
2. Turn the control using the key blade.
 - A. The door cannot be opened from inside.
 - B. The door can be opened from inside.

Electric child safety locks for the doors and disabling the rear window buttons (option)

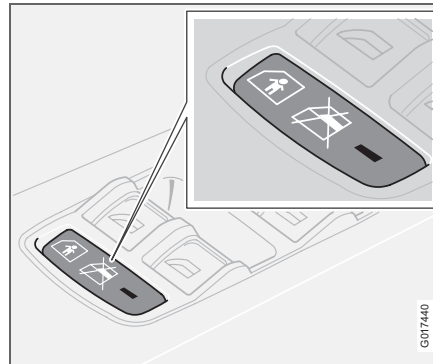

When the electric child safety lock is active:

- the rear windows can only be opened with the driver's door control panel.
 - the rear doors cannot be opened from the inside.
1. Child safety locks are activated in key position **I** or **II**.
 2. Press the switch on the driver's door. A message appears on the information display. The lamp in the button illuminates when the lock is active.

i NOTE

Cars with electric child safety locks do not also have manual child locks.

! WARNING

Always keep the doors unlocked when driving. In the event of an accident, this allows the emergency services to get into the car quickly. Passengers in the rear seat cannot open the doors from inside if the child safety locks are activated.



Alarm (option)

Alarm system

When the alarm is armed, it continually monitors all alarm inputs.

The alarm is triggered if:

- a door, the bonnet or tailgate opens
- a non-approved key is used in the ignition or if an attempt is made to force the lock.
- a movement is detected in the passenger compartment (if fitted with a movement detector).
- the car is raised or towed away (if fitted with a tilt detector).
- a battery cable is disconnected.
- anyone tries to disconnect the siren.

Alarm light on instrument panel

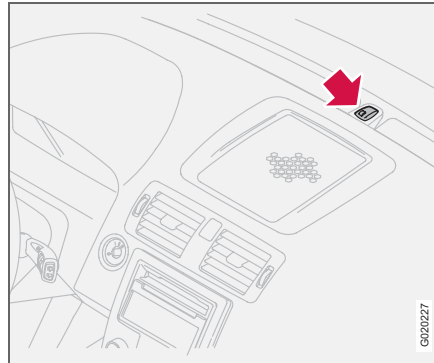

A light on the instrument panel indicates the alarm system's status:

- Light not lit – the alarm is not armed.
- The light flashes rapidly after disarming the alarm and until the ignition is switched on – the alarm has been triggered.
- The lamp flashes once every other second after the car's direction indicators have made one long flash signal – Alarm is armed.

If there is a fault in the alarm system, a message appears on the information display. Contact an authorised Volvo workshop.



NOTE

Do not attempt to repair or modify alarm system components. All such attempts may affect the terms of insurance.

Arming the alarm

- Press the lock button on the remote control. A long flash from the car's direction indicators confirms that the alarm is armed and that the doors are locked.



IMPORTANT

The alarm is fully armed when the car's direction indicators have made one long flash and the light on the instrument panel flashes once every other second.

Disarming the alarm

- Press the unlock button on the remote control. Two short flashes from the car's direction indicators confirm that the alarm is disarmed and that the doors are unlocked.

Automatic alarm activation

This function prevents you accidentally leaving the car without the alarm on.



Alarm (option)

If none of the doors or the tailgate are opened within two minutes of disarming the alarm (and the car has been unlocked with the remote control), the alarm is automatically rearmed, and the car is locked at the same time.

Deactivating a triggered alarm

- Press the unlock button on the remote control or insert the key in the ignition switch.

Confirmation is given by two short flashes from the direction indicators.

Alarm signals

When the alarm is triggered, the following happens:

- A siren sounds for no more than 25 seconds. The siren has its own battery which is used if the car battery has insufficient charge or is disconnected.
- The direction indicators flash for five minutes or until the alarm is deactivated.

Remote control not working

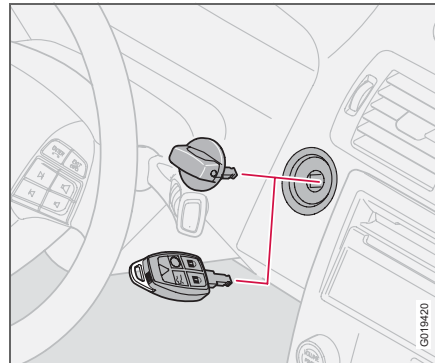

If for some reason the remote control is not working, the alarm can still be switched off and the car started as follows:

- Open the driver's door with the key blade. The alarm is triggered and the siren sounds.
- On cars with the keyless drive system: First remove the knob by pressing in the catch (1) and pulling out (2).
- Insert the remote control into the ignition switch (3). The alarm is deactivated. The alarm light flashes rapidly until the ignition key is turned to position II.



Alarm (option)

Reduced alarm level

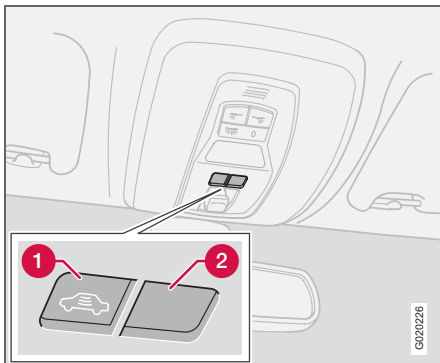

1. Deactivation of the deadlocks and detectors.
2. No function.

To avoid inadvertently triggering the alarm, for example during a ferry crossing, the movement and tilt detectors can be temporarily deactivated as follows.

- Turn the ignition key to position **II** and then back to position **0**. Remove the key.
- Press button (1). The light in the button is illuminated until the car is locked.

A message is shown on the display as long as the key remains in the ignition switch (and for one minute after the key is removed).

If the car is equipped with deadlocks, they are deactivated at the same time, see page 110.

The detectors are reactivated and deadlocks re-engaged the next time the car is started.

**Alarm (option)****Testing the alarm system****Testing the movement detector in the passenger compartment**

- Open all the windows.
- Arm the alarm. Arming the alarm is confirmed by the light flashing slowly.
- Wait 30 seconds.
- Test the movement detector in the passenger compartment, such as by lifting out a bag from a seat. A siren should sound and all direction indicators should flash.
- Deactivate the alarm by unlocking the car with the remote control.

Testing the doors

- Arm the alarm.
- Wait 30 seconds.
- Unlock the driver's door with the key blade.
- Open one of the doors. A siren should sound and all direction indicators flash.
- Deactivate the alarm by unlocking the car with the remote control.

Testing the bonnet

- Sit in the car and deactivate the movement detector.

- Arm the alarm. Remain in the car and lock the doors with the button on the remote control.
- Wait 30 seconds.
- Open the bonnet with the handle under the dashboard. A siren should sound and all direction indicators flash.
- Deactivate the alarm by unlocking the car with the remote control.

General	118
Refuelling	120
Starting the engine	121
Starting the engine – Flexifuel	123
Keyless drive (option)	124
Manual gearbox	125
Automatic gearbox	127
All-wheel drive	130
Brake system	131
Stability and traction control system	133
Parking assistance (option)	135
BLIS – Blind Spot Information System (option)	138
Towing and recovery	142
Start assistance	144
Driving with a trailer	145
Towing equipment	147
Detachable towbar	149
Loading	154
Adjusting headlamp pattern	155

STARTING AND DRIVING



06



General

Economical driving

Driving economically means driving smoothly while thinking ahead and adjusting your driving style and speed to the prevailing conditions.

- Get the engine warmed up as soon as possible.
- Do not let the engine idle, but drive at light loads as soon as it is possible.
- A cold engine consumes more fuel than a warm one.
- Avoid braking too hard.
- Do not drive with unnecessary loads in the car.
- Do not use winter tyres when the roads are dry.
- Remove load carriers when they are not being used.
- Avoid driving with open windows.

Slippery driving conditions

Practise driving on slippery surfaces under controlled conditions to learn how the car reacts.

Engine and cooling system

Under special conditions, for example when driving in hilly terrain, extreme heat or with heavy loads, there is a risk that the engine and cooling system will overheat.

Avoid overheating the cooling system

- Maintain a low speed when driving with a trailer up long, steep ascents.
- Do not turn the engine off immediately you stop after a hard drive.
- Remove any auxiliary lamps from in front of the grille if driving in extreme high temperatures.

Avoid overheating the engine

Do not exceed engine speeds of 4500 rpm (diesel engine: 3500 rpm) if driving with a trailer or caravan in hilly terrain. The oil temperature could then become too high.

Open tailgate

Avoid driving with the tailgate open. If it is necessary to drive with the tailgate open for a short distance:

- Close all windows.
- Set the air distribution to the windscreen and floor and run the fan at high speed.



WARNING

Do not drive with the tailgate open. Toxic exhaust fumes can be drawn into the car through the cargo area.

Driving in water

The car can be driven through water at a maximum depth of 25 cm at a maximum speed of 10 km/h. Extra caution should be exercised when passing through flowing water.



IMPORTANT

Engine damage can occur if water enters the air filter. In greater depths, water can enter the transmission. This reduces the lubricating ability of the oils and shortens the service life of these systems.

When driving in water, maintain a low speed and do not stop the car. When the water has been passed, depress the brake pedal lightly and check that full brake function is attained. Water and mud for example can make the brake linings wet resulting in delayed brake function.

Clean the electric contacts of the electric engine block heater and trailer coupling after driving in water and mud.

**IMPORTANT**

Do not let the car stand with water over the sills for any long period of time. This could cause electrical malfunctions. In the event of stalling in water, do not try to restart. Tow the car out of the water.

Do not overload the battery

The electrical functions in the car load the battery to varying degrees. Avoid using the ignition position **II** when the engine is switched off. Use ignition position **I** instead, as less power is consumed.

Examples of functions that use a lot of power:

- ventilation fan
- windscreen wipers
- audio equipment (high volume)
- parking lights

Also, be aware of different accessories that load the electrical system. Do not use functions which use a lot of power when the engine is switched off.

If the battery voltage is low, a message appears on the display. The energy-saving function shuts down certain functions or reduces the load on the battery by, for example, slowing the ventilation fan and switching off the audio equipment. Charge the battery by starting the engine.



Refuelling

Opening the fuel filler flap

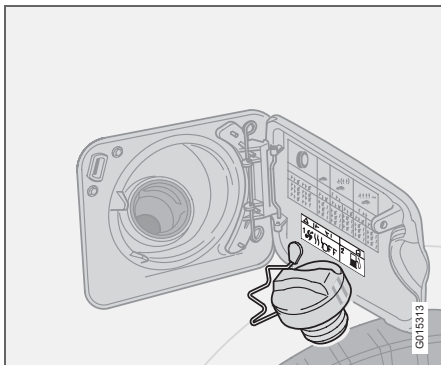

Switch off the fuel-driven heater before refuelling.

Open the fuel filler flap with the button on the lighting panel, see page 47. The engine must be switched off before the flap can be opened. The fuel flap is located on the rear right wing.

Closing

Push in the flap until you hear a click.

Fuel cap

1. Turn the fuel cap until an obvious resistance is felt.
2. Turn past the resistance until it comes to a stop.

3. Take out the cap.
4. Hang up the cap on the inside of the fuel filler flap.

NOTE

Put the petrol cap back after refuelling. Turn until one or more clear clicks are heard.

Filling up with fuel

Do not overfill the tank but fill until the pump nozzle cuts out.

NOTE

Excess fuel in the tank can overflow in hot weather.

Fuel of a lower quality than that specified on page 247 should not be used as engine power and fuel consumption can be negatively affected.

WARNING

Fuel which spills on to the ground can be ignited by the exhaust fumes.

Switch off the fuel-driven heater before starting to refuel.

Never carry an activated mobile phone when refuelling the ring signal could cause spark build-up and ignite petrol fumes, leading to fire and injury.

Petrol

! IMPORTANT

Do not add cleaning additives to the petrol, unless recommended by Volvo.

Diesel

At low temperatures (-5°C to -40°C), a paraffin precipitate may form in the diesel fuel, which can lead to ignition problems.

! IMPORTANT

Use special winter grade fuel during cold months.



Starting the engine

Before starting the engine

- Apply the parking brake.

Automatic gearbox

- Gear selector in position **P** or **N**.

Manual gearbox

Put the gear lever in neutral and hold the clutch pedal fully depressed. This is particularly important in very cold conditions.

WARNING

Never remove the ignition key from the steering lock while driving or when the car is being towed. The steering lock could otherwise be activated, making it impossible to steer the car.

The ignition key must be in position **II** when the car is being towed.

NOTE

The idling speed can be noticeably higher than normal for certain engine types during cold starting. This is so that the emissions system can reach normal operating temperature as quickly as possible, which minimises exhaust emissions and protects the environment.

Starting the engine

Petrol

- Turn the ignition key to position **III**.
If the engine does not start within 5–10 seconds, release the key and try again.

Diesel

1. Turn the ignition key to position **II**.
An indicator symbol in the combined instrument panel shows that engine preheating is underway, see page 41.
2. Turn the ignition key to position **III** when the indicator symbol goes out.

Autostart (5-cylinder)

With the autostart function, there is no need to hold the ignition key (or ignition dial on cars with Keyless Drive, see page 104) in position **III** until the engine has started.

Turn the ignition key to the start position and then release. The starter motor then works automatically until the engine has started.

NOTE

If the diesel engine is started in extreme cold without waiting for engine preheating, then the automatic start sequence can be delayed for a couple of seconds.

Diesel particle filter (DPF)¹

Diesel cars may be equipped with a particle filter, which results in more efficient emission control. The particles in the exhaust gases are collected in the filter during normal driving. So-called "regeneration" is started in order to burn away the particles and empty the filter. This requires the engine to have reached normal operating temperature.

Regeneration of the filter takes place automatically at an interval of 300 – 900 km depending on driving conditions. Regeneration normally takes between 10 and 20 minutes. During this time fuel consumption may increase slightly.

The rear window heating may be activated automatically to increase the load on the engine during regeneration without warning.

Regeneration in cold weather

If the car is frequently driven short distances in cold weather then the engine does not reach normal operating temperature. This means that regeneration of the diesel particle filter does not take place and the filter is not emptied.

When the filter has become approximately 80 % full of particles, the yellow information

¹ Certain markets



Starting the engine

symbol on the instrument panel illuminates, and the message **SOOT FILTER FULL** **SEE MANUAL** is shown on the instrument panel display.

Start regeneration of the filter by driving the car until the engine reaches normal operating temperature, preferably on a main road or motorway. The car should then be driven for approximately 20 minutes more.

When regeneration is complete the message is cleared automatically.



IMPORTANT

If the filter fills up it may be incapable of functioning. Then it can be difficult to start the engine and there is a risk that the filter will have to be replaced.

Use the parking heater (option) in cold weather so that the engine reaches normal operating temperature more quickly.

Ignition keys and electronic immobiliser

The ignition key must not hang with other keys or metal objects on the same key ring. Otherwise the electronic immobiliser could be activated accidentally.

Ignition switch and steering lock

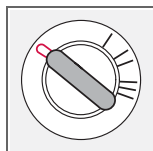

0 – Locked position

The steering lock is activated when the key is removed from the lock.

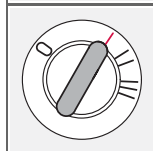

I – Radio position

Certain electrical components can be switched on. The engine's electrical system is not activated.

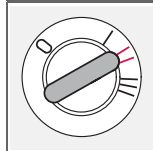

II – Driving position

The key position when driving. The car's electrical system is energised.

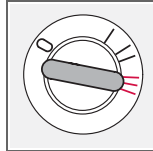

III – Start position

The starter motor is engaged. Release the key, which springs back automatically to the driving position, once the engine has started.

A ticking sound may be heard if the key is between positions. Turn the key to position II and back to eliminate the sound.

When the steering lock is activated

If the front wheels are positioned so that there is tension in the steering lock, a warning message may be shown in the information display and the car prohibited from starting.

1. Remove the key and turn the steering wheel to release the tension.
2. Hold the steering wheel in this position. Reinsert the key and make a new attempt to start the car.



WARNING

Never remove the ignition key from the ignition switch while driving or when the car is being towed. The steering lock could otherwise be activated, making it impossible to steer the car.



WARNING

Always remove the ignition key from the ignition when leaving the car, especially if there are children in the car.

Make sure the steering lock is activated when the car is left to reduce the risk of theft.



Starting the engine – Flexifuel

General information about starting with Flexifuel

- Do not allow the starter motor to be engaged for longer than 30 seconds.
- Release the ignition key as soon as the engine has started.
- The immobiliser is activated in the event of repeated start attempts. Before the start attempts can then be repeated the key must first be turned back to position I or 0.

In the event of starting difficulties

If the engine does not start as above then proceed as follows:

- Depress the accelerator pedal 1/3 to 1/2.
- Turn the ignition key to position III.
- Release the key when the engine has started and gradually ease off the accelerator pedal as the engine speed increases.

If the engine still does not start:

- Depress the accelerator pedal and repeat the last two steps.

Starting in low outside temperatures

If the temperature is expected to be lower than $-10\text{ }^{\circ}\text{C}$, then the recommendation is to increase the concentration of petrol in the tank by refuelling with unleaded petrol 95 octane if possible.

Approx. 10 litres of 95 octane petrol will decrease the proportion of bioethanol E 85 in a three-quarters full tank from 85 % to 70 % which improves the cold starting properties considerably.



NOTE

If the tank is only refuelled with bioethanol E85 and the engine is not preheated then it will be difficult to start in extreme cold.

Driveability – adaptation

Idling speed may be uneven after disconnecting the battery or changing fuel type. The engine then adapts to the new fuel mixture - i.e. adaptation.

Adaptation continues for a short time following a change of fuel type. A slightly longer period of driving is required when the car has been de-energised.

Engine block heater

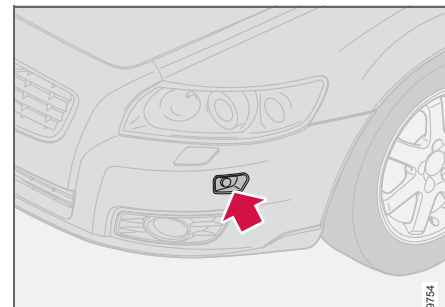

Connecting the engine block heater

An engine block heater should be used to facilitate the quick starting of the engine when the temperature is expected to be lower than $-10\text{ }^{\circ}\text{C}$ and the car has been refuelled with bioethanol E85.

Cars designed for Flexifuel have an electric engine block heater as standard equipment¹. Starting and driving with a preheated engine involves significantly lower emissions and reduced fuel consumption. For this reason you should aim to use the engine block heater throughout the winter months.

Read more about Flexifuel's bioethanol E85 fuel on page 247.

¹ Option on other engines



Keyless drive (option)

General

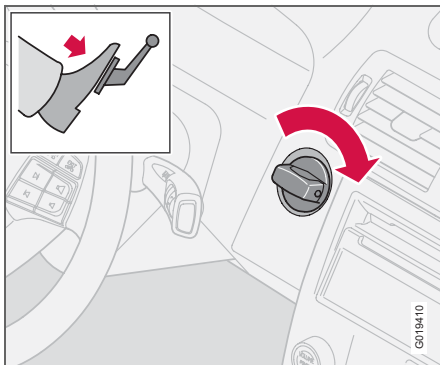

The keyless drive function allows the car to be unlocked, driven and locked without the need for a key, see page 104.

The ignition switch ignition dial is used in the same way as the key. One precondition for starting the car is that the car's remote control is located inside the passenger compartment or the cargo area.

Starting the car

- Depress the clutch pedal (cars with manual gearbox) or brake pedal (cars with automatic gearbox).

Petrol engine

- Press in and turn the ignition dial to position **III**.

Diesel engine

1. First turn the ignition dial to position **II** and wait until the diesel indicator symbol in the combined instrument panel goes out, see page 41.
2. Following which, turn the ignition dial to position **III**.

Starting with the remote control

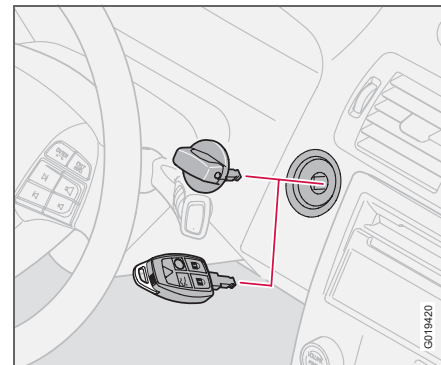

If the remote control battery is discharged then the Keyless Drive function does not work. In which case, start the car by using the remote control as ignition dial.

1. Press in the catch in the ignition dial.
2. Pull the ignition dial out from the ignition switch.
3. Insert the remote control into the ignition switch and start in the same way as with the ignition dial.



Manual gearbox

Gear positions, five-speed

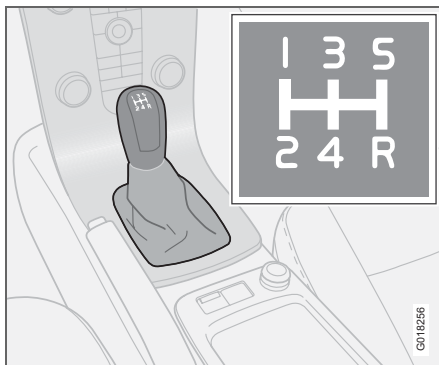

Depress the clutch pedal fully with each gear change. Remove your foot from the clutch pedal between gear changes! Follow the appropriate shifting pattern.

For the best possible fuel economy, use the highest gear possible as often as possible.

Reverse gear inhibitor, five-speed

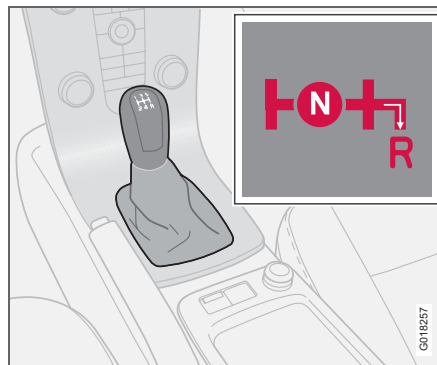

Only engage reverse gear when the car is stationary. To engage reverse gear, the gear lever must first be put in position **N**. Reverse gear cannot therefore be engaged directly from fifth gear due to the reverse gear inhibitor.

Gear positions, six-speed (petrol)

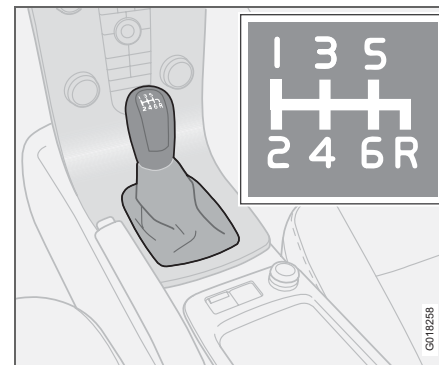

Depress the clutch pedal fully with each gear change. Remove your foot from the clutch pedal between gear changes! Follow the appropriate shifting pattern.

For the best possible fuel economy, use the highest gear possible as often as possible.

It can be difficult to find the positions for fifth and sixth gear when the car is stationary as the reverse gear inhibitor (which blocks sideways movement towards reverse) is then not activated.



Manual gearbox

Reverse gear inhibitor, six-speed (petrol)

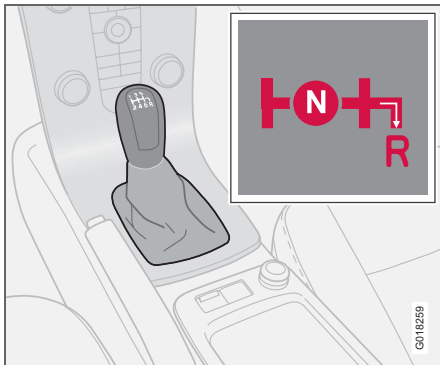

Only engage reverse gear when the car is stationary.

NOTE

Reverse gear is electronically blocked if the car is travelling faster than approx. 20 km/h.

Gear positions, six-speed (diesel)¹

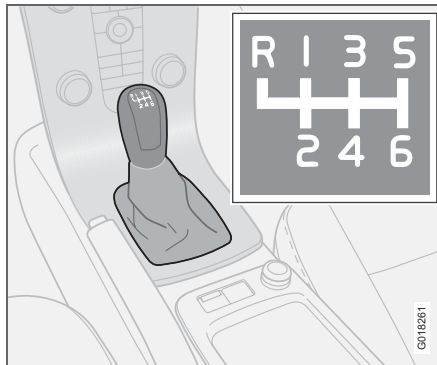

Depress the clutch pedal fully with each gear change. Remove your foot from the clutch pedal between gear changes! Follow the appropriate shifting pattern.

For the best possible fuel economy, use the highest gear possible as often as possible.

Reverse gear inhibitor, six-speed (diesel)

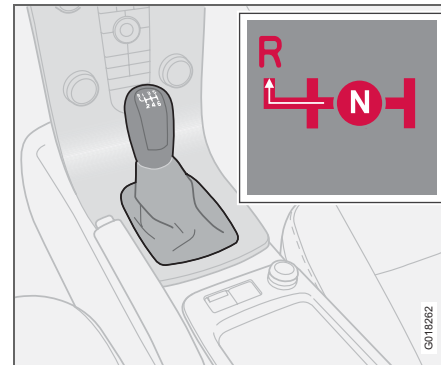

Only engage reverse gear when the car is stationary. Engage reverse gear by pressing down the gear lever and moving it to the left.

¹Certain markets



Automatic gearbox

Geartronic automatic gear positions

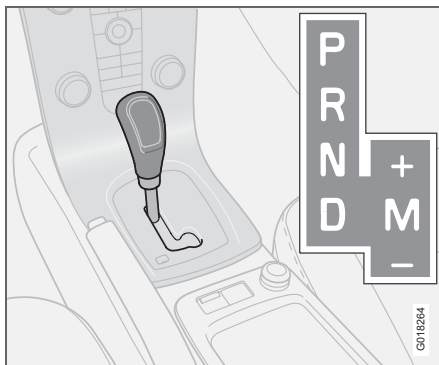

P – Parking position

Select position **P** when you wish to start the engine or park the car.

IMPORTANT

The car must be stationary when position **P** is selected.

NOTE

The brake pedal must be depressed to move the gear lever from the **P** position.

The gearbox is mechanically blocked when **P** position is engaged. Always apply the parking brake when parking the car.

R – Reverse

The car must be stationary when **R** is selected.

N – Neutral

No gear is engaged and the engine can be started. Apply the parking brake when the car is stationary with the gear selector in position **N**.

D – Drive

D is the normal driving position. The car automatically shifts up and down depending on the level of acceleration and speed. The car should be stationary when **D** is selected from position **R**.

Geartronic manual gear positions

The driver can also change gear manually using the Geartronic automatic gearbox. The car engine-brakes when the accelerator pedal is released.

Manual gearshift mode is obtained by moving the lever from position **D** to the right-hand end position at **M**. The information display shifts the indication from **D** to one of the figures **1-6**, depending which gear is engaged just then, see page 39.

Move the lever forwards towards **+** (plus) to change up a gear and release the lever, which returns to its rest position at **M**. Pull the lever back towards **-** (minus) to change down a gear and release the lever.

The manual gearshift mode **M** can be selected at any time while driving.

To return to automatic driving mode: move the lever to the left-hand end position at **D**.

Geartronic automatically shifts down if the driver allows the speed to decrease lower than a level suitable for the selected gear, in order to avoid jerking and stalling.



Automatic gearbox

Kick-down¹

When the accelerator pedal is pressed all the way to the floor (beyond the position normally regarded as full acceleration) a lower gear is immediately engaged. This is known as kick-down.

If the accelerator is released from the kick-down position, the gearbox automatically changes up.

Kick-down is used when maximum acceleration is needed, such as for overtaking.

Safety function

To prevent overrevving the engine, the gearbox control program has a protective down-shift inhibitor which prevents the kick-down function.

Geartronic does not permit downshifting/ kick-down which would result in an engine speed high enough to damage the engine. Nothing happens if the driver still tries to shift down in this way at high engine speed – the original gear remains engaged.

When kick-down is activated the car can change one or more gears at a time depending on engine speed. The car changes up when the engine reaches its maximum speed in order to prevent damage to the engine.

¹ Not on diesel cars in manual position.

Mechanical gear selector inhibitor

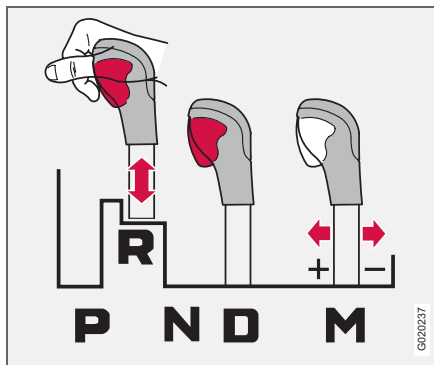

The gear selector can be moved forward and back freely between **N** and **D**. Other positions are locked with a latch that is released with the inhibitor button on the gear selector.

With the inhibitor button depressed the lever can be moved forwards or backwards between **P**, **R**, **N** and **D**.

Automatic gear selector inhibitor

Cars with an automatic gearbox have special safety systems:

Keylock

To remove the ignition key, the gear selector must be in the **P** position. The key is locked in all other positions.

Parking position (P)

Stationary car with engine running:

- Hold your foot on the brake pedal when moving the gear selector to another position.

Electric gear inhibitor – Shiftlock

Parking position (P position)

To be able to move the gear selector from the **P** position to other gear positions, the ignition key must be in position **II** and the brake pedal must be depressed.

Shiftlock – Neutral (N position)

If the gear selector is in the **N** position and the car has been stationary for at least three seconds (irrespective of whether the engine is running) then the gear selector is locked in the **N** position.

To be able to move the gear selector from the **N** position to another gear position, the brake pedal must be depressed and the ignition key must be in position **II**.



Automatic gearbox

Disengaging the gear selector inhibitor

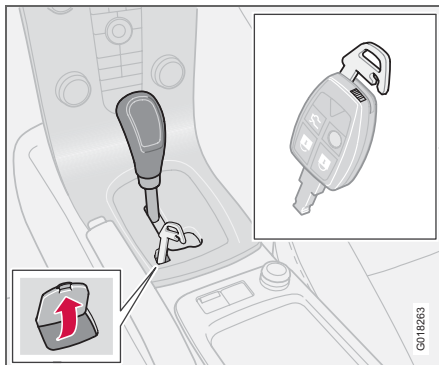

In certain cases, it may be necessary to move the car when it is not driveable, for example if the battery is flat. Proceed as follows to move the car:

1. There is a small cover behind **P-R-N-D** on the gear selector panel. Open the rear edge.
2. Fully insert the key blade from the remote control.
3. Hold the key blade down and at the same time move the gear lever out of the **P** position.

Cold start

When starting in low temperatures, the gear changes can sometimes feel hard. This is due to the gearbox oil's viscosity at low temperatures. To minimise engine emissions, the gearbox shifts up later than normal when the engine is started at low temperatures.

i NOTE

Depending on the engine temperature when the engine is started, the idle speed after a cold start may be higher than normal for certain engine types.



All-wheel drive

All-wheel drive – AWD

All-wheel drive is always engaged.

All-wheel drive means that all four road wheels are driven at the same time. Power is automatically distributed between front and rear wheels. An electronically controlled clutch system distributes the power to the pair of wheels that grips best. This provides the best traction and prevents wheel spin.

Under normal driving conditions, the majority of power is transmitted to the front wheels.

All-wheel drive improves driving safety in rain, snow and icy conditions.



Brake system

Brake servo

If the car is rolling or is being towed with the engine turned off, the brake pedal must be pressed about five times harder than when the engine is running. If the brake pedal is pressed when the engine is started, you will feel the pedal drop. This is normal and due to the brake servo becoming active. This may be more noticeable if the car has emergency brake assistance (EBA).



WARNING

The brake servo only works when the engine is running.



NOTE

If braking with the engine switched off, press the brake pedal sharply once, not repeatedly.

Brake circuits



This symbol illuminates if a brake circuit is not working.

If a fault should occur in one of the circuits, it is still possible to

brake the car. The brake pedal will travel further and may feel softer than normal. Harder pressure on the pedal is needed to produce the normal braking effect.

Dampness can affect braking characteristics

Brake components become wet when the car is driven in heavy rain, through pools of water or when the car is washed. This may alter brake pad friction characteristics so that there is a delay before braking effect is noticed.

Press the brake pedal lightly from time to time if driving for long stretches in rain or slushy snow, as well as after setting off in very damp or cold weather. This warms up the braking surfaces and dries off any water. It is also recommended to do this before parking the car for a long period in such weather conditions.

If the brakes are used heavily

When driving in the Alps or other roads with similar characteristics, the car's brakes are heavily loaded even if the brake pedal is not being depressed especially hard.

Because speed is often low, the brakes are not cooled as effectively as when driving on flat roads at higher speed.

So as not to overload the brakes, shift down when driving downhill instead of using the foot brake. Use the same gear driving downhill as you would use driving uphill. This uses

engine braking more efficiently and requires the foot brake for only brief periods.

Bear in mind that driving with a trailer puts an additional load on the car's brakes.

Anti-lock braking system (ABS)



The anti-lock braking system (ABS) prevents the wheels from locking up under braking.

This means the ability to steer is maintained and it is easier to swerve to avoid a hazard, for example.

After the engine has been started, the ABS will perform a brief self-test at a speed of about 20 km/h. This can be felt and heard as pulses in the brake pedal.

To get the most out of the ABS:

1. Depress brake pedal with full force. Pulses will be felt.
2. Steer the car in the direction of travel. Do not release the pressure on the pedal.

Practice braking with the ABS system in a traffic-free area and in different weather conditions.

The ABS symbol illuminates for two seconds if there was a fault in the ABS system when the engine was last running.



Brake system

Emergency brake assistance – EBA

(Emergency brake assistance) In case of sudden braking, full-strength braking is provided instantaneously. The EBA function senses when heavy braking is underway by registering how quickly the brake pedal is depressed. Continue braking without easing off on the brake pedal. The function is suspended when the pressure on the brake pedal eases. This function is always active and cannot be disengaged.



NOTE

When EBA is activated the brake pedal lowers slightly more than usual, depress (hold) the brake pedal as long as necessary. If the brake pedal is released then all braking ceases.



WARNING

If the BRAKE and ABS warning symbols are lit at the same time, a fault may have occurred in the brake system. If the level in the brake fluid reservoir is normal, drive carefully to the nearest authorised Volvo workshop to have the brake system checked.

If the brake fluid is below the MIN level in the brake fluid reservoir, do not drive further before topping up the brake fluid.

The reason for the loss of brake fluid must be investigated.



Stability and traction control system

General

The Dynamic Stability and Traction Control system (STC/DSTC) improves the car's traction and helps the driver to avoid skidding.

A pulsing sound may be noticed during braking or acceleration when the system is in action. The car may accelerate more slowly than expected.

The car is equipped with either STC or DSTC depending on market. The table shows the integral functions of the respective systems.

Function/system	STC	DSTC
Active Yaw Control		X
Spin Control	X	X
Traction control system	X	X

Active Yaw Control

The function limits the driving and brake force of the wheels individually in order to stabilise the car.

Spin Control

The function prevents the driving wheels from spinning against the road surface during acceleration.

Traction control system

The function is active at low speed and transfers power from the driving wheel that is spinning to the one that is not.

Reduced operation

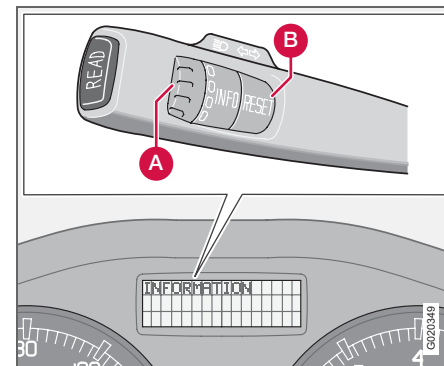

The stability system is activated automatically each time the car is started.

System operation during skidding and acceleration can be partially deactivated.

Operation during skidding is delayed and so allows more skidding which provides greater freedom for dynamic driving.

Traction in deep snow or sand is improved as acceleration is no longer limited.

Operation

- Turn thumbwheel (A) until the STC/DSTC menu is shown.



Stability and traction control system

DSTC ON means that the system function is unchanged.

DSTC SPIN CONTROL OFF means that system operation is reduced.

- Press and hold **RESET** (B) until the STC/DSTC menu is changed.

At the same time the symbol  illuminates as a reminder that the system has been reduced. The system remains reduced until the engine is next started.

WARNING

Suppressing system function may alter the driving characteristics of the car.

NOTE

DSTC ON is shown for several seconds on the display and the symbol  illuminates each time the engine is started.

Messages in the information display

TRACTION CONTROL TEMPORARILY OFF means that the system has been temporarily reduced due to excessive brake disc temperature.

The function is reactivated automatically when the brakes have cooled.

ANTI-SKID SERVICE REQUIRED means that the system has been disabled due to a fault.

- Stop the car in a safe place and turn off the engine.

If the message remains when the engine is restarted, drive to an authorised Volvo workshop.



Symbols in the combined instrument panel



DSTC system



Information

If the symbols  and  are displayed at the same time, read the message on the information display.

If the symbol  appears alone then it may appear as follows:

- Flashing light means that the STC/DSTC system is now being activated.
- Constant glow for two seconds means system check when the engine is started.

- Constant glow after starting the engine or while driving means that there is a fault in the STC/DSTC system.
- Constant glow after deactivation reminds that the STC/DSTC system has been reduced.



Parking assistance (option)

General information on parking assistance¹

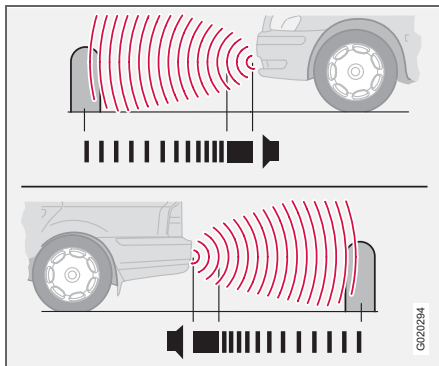

Parking assistance front and rear

Parking assistance is used as an aid to parking. A signal indicates the distance to a detected obstacle.

WARNING

Parking assistance does not relinquish the driver's own responsibility during parking. The sensors have blind spots where obstacles cannot be detected. Be aware of children and animals near the car.

¹ Depending on the market, the **Parking assistance system** may be either standard, option or accessory.

Variants

Parking assistance is available in two variants:

- Rear only
- Both front and rear.

Function

The frequency of the signal increases the shorter the distance to an obstacle in front of or behind the car. If the volume of another sound source from the audio system is high, this is automatically muted.

The tone becomes constant at a distance of about 30 cm. If there are obstacles within this distance both behind and in front of the car, the signal alternates between left and right-hand speakers.

Rear parking assistance only

The system is automatically engaged when the car is started.

Rear parking assistance is activated when reverse gear is engaged and the message **Park Assist active, Exit to deactivate** is shown on the audio system display.

If the system is switched off, the display shows **Park Assist deactivated Enter to activate** as soon as reverse gear is engaged. To change the settings, see page 66.

The distance covered behind the car is about 1.5 metres. The signal comes from the rear loudspeakers.

Limitations

The system must be deactivated when reversing with a trailer, or bike carrier on the towbar or similar. Otherwise the trailer or bike carrier would trigger the sensors.

NOTE

Rear parking assistance is deactivated automatically when towing a trailer if a Volvo genuine trailer cable is used.



Parking assistance (option)

Parking assistance both front and rear

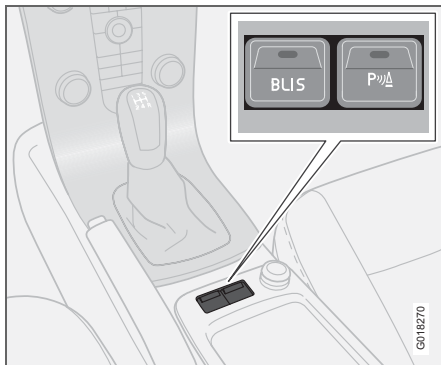

Button for Off/On (here right-hand button).

The system is automatically activated when the car is started and the lamp in the switch for Off/On is illuminated. If parking assistance is deactivated with the button, then the lamp goes out.

Front

Front parking assistance is active at speeds below 15 km/h. The system is deactivated at higher speeds. The system is reactivated when the speed falls below 10 km/h again.

The distance covered to the front of the car is about 0.8 metres. The signal for obstacles in front comes from the front loudspeakers.

Limitations

Front parking assistance cannot be combined with extra lights because the sensors are affected by the extra lights.

Rear

Rear parking assistance is activated when reverse gear is engaged.

The distance covered to the rear of the car is about 1.5 metres. The signal for obstacles behind comes from the rear loudspeakers.

Limitations

See the previous section *Rear parking assistance only*.

Fault indicator



If the information symbol illuminates with constant glow and the display shows **PARK ASSIST SERVICE REQUIRED** then parking assistance is disengaged.

Contact an authorised Volvo workshop for attention.



IMPORTANT

In certain conditions the parking assistance system may produce incorrect warning signals that are caused by external sound sources that emit the same ultrasonic frequencies that the system works with.

Examples of such sources include horns, wet tyres on asphalt, pneumatic brakes and exhaust noises from motorcycles etc.



Parking assistance (option)

Cleaning the sensors

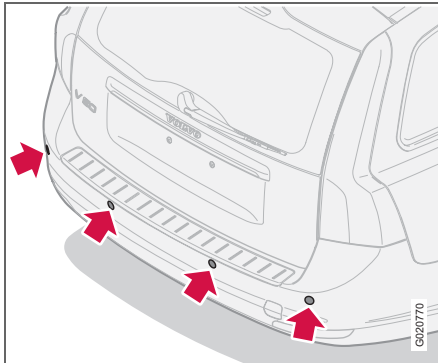

Parking assistance sensors

The sensors must be cleaned regularly to ensure that they work properly. Clean them with water and car shampoo.

i NOTE

Dirt, ice and snow covering the sensors may cause incorrect warning signals.

BLIS – Blind Spot Information System (option)

General

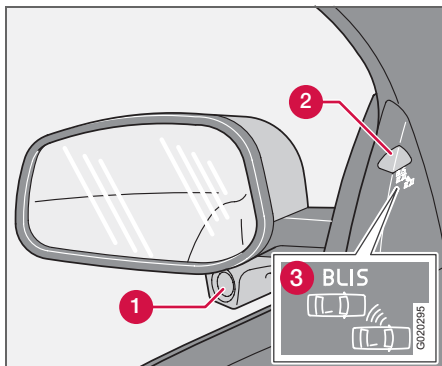

Rearview mirror with BLIS system.

1. BLIS camera
2. Indicator lamp
3. BLIS symbol

WARNING

The system is a supplement to, not a replacement for, a safe driving style and use of the rearview mirrors. It can never replace the driver's attention and responsibility. The responsibility for changing lanes safely always rests with the driver.

BLIS is an information system that under certain conditions can help to draw the driver's

attention to vehicles moving in the same direction in the so-called "blind spot".

The system is designed to work most effectively when driving in dense traffic on multi-lane highways.

BLIS is based on digital camera technology. The cameras (1) are located under the door mirrors.

When a camera has detected a vehicle inside the blind spot zone the indicator lamp (2) illuminates with a constant glow.

NOTE

The light illuminates on the side of the car where the system has detected the vehicle. If the car is overtaken on both sides at the same time then both lights illuminate.

BLIS advises the driver with a message if a fault arises in the system. If for example the system's cameras are obscured then the BLIS indicator lamp flashes and the instrument panel's display shows a message. In such cases, check and clean the lenses. If necessary, the system can be switched off temporarily by pressing the BLIS button, see page 139.

Blind spots

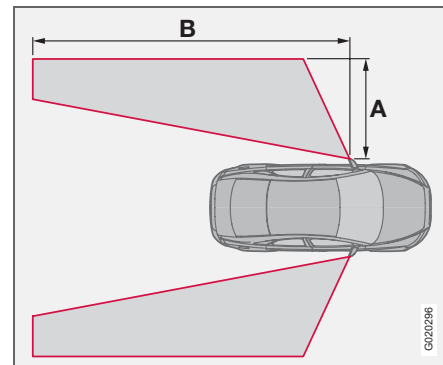

A = approx. 3.0 m, B = approx. 9.5 m.

When BLIS operates

The system operates when the car is driven at a speed above 10 km/h.

Overtaking

The system is designed to react if you overtake another vehicle at a speed of up to 10 km/h faster than the other vehicle.

The system is designed to react if you are overtaken by a vehicle travelling up to 70 km/h faster than your vehicle.



BLIS – Blind Spot Information System (option)

WARNING

BLIS does not work in sharp bends.

BLIS does not work when the car is reversing.

A wide trailer coupled to the car can conceal other vehicles in adjacent lanes. It can prevent the vehicle in the screened area from being detected by BLIS.

Daylight and darkness

In daylight the system reacts to the shape of the surrounding vehicles. The system is designed to detect motor vehicles such as cars, trucks, buses and motorcycles.

In darkness the system reacts to the headlamps of surrounding vehicles. Vehicles with headlamps that are switched off are not detected by the system. This means for example that the system does not react to a trailer without headlamps which is towed behind a car or truck.

WARNING

The system does not react to bicycles or mopeds.

The BLIS cameras can be disrupted by intensive light or when driving in the dark when there are no light sources (e.g. street lighting or other vehicles). The system may then interpret the lack of light as if the cameras have been blocked.

In both cases a message is shown on the information display.

When driving in such conditions system performance may be temporarily reduced and a text message is shown, see page 140.

If the message disappears automatically then BLIS has returned to normal functionality.

The BLIS cameras have limitations similar to the human eye, i.e. they "see" worse in heavy snowfall or thick fog for example.

Activating/deactivating

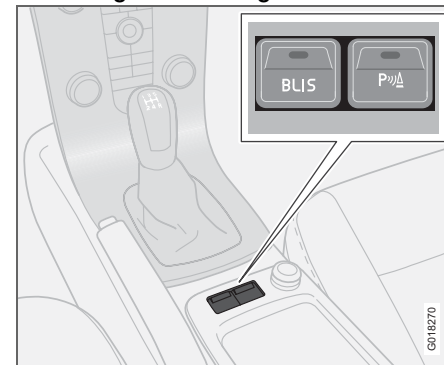

Button for activating/deactivating.

BLIS is activated when the engine is started. The indicator lamps in the door panels flash three times when BLIS is activated.

The system can be deactivated/activated by pressing **BLIS**.

When BLIS is deactivated the light in the button goes out and a text message is shown on the dashboard display.

When BLIS is activated the light in the button illuminates, a new text message is shown on the display and the indicator lamps in the door panels flash three times. Press the **READ** button to clear the text message. For more information on messages, see page 44.



BLIS – Blind Spot Information System (option)

BLIS system message

Text on the display	Specification
BLIND-SPOT INFO SYSTEM ON	BLIS system on.
BLIS FUNCTION REDUCED	The BLIS camera is disrupted by fog or strong sunlight, for example, shining directly into the camera. The camera resets itself when the environment has returned to normal.
BLIND-SPOT SYST CAMERA BLOCKED	One or both cameras blocked. Clean the lenses.
BLIND-SPOT SYST SERVICE REQUIRED	Blind spot syst. disengaged. Contact an authorised Volvo workshop.
BLIND-SPOT INFO SYSTEM OFF	BLIS system off.



IMPORTANT

Repair of the BLIS system components must only be performed by an authorised Volvo workshop.

Cleaning

In order to work most effectively the BLIS camera lenses must be clean. The lenses can be cleaned with a soft cloth or damp sponge. Clean the lenses carefully so that they are not scratched.



IMPORTANT

The lenses are electrically heated to melt ice or snow. If necessary, brush snow away from the lenses.



BLIS – Blind Spot Information System (option)

Limitations

In some situations the BLIS indicator lamp may illuminate despite there being no other vehicle within the blind spot.

NOTE

If the BLIS indicator lamp illuminates on isolated occasions despite there being no other vehicle within the blind spot then this does not mean that a fault has arisen in the system.

In the event of a fault in the BLIS system the display shows the text **BLIS Serv. required.**

Here are several examples of situations where the BLIS indicator lamp may illuminate even if there is no other vehicle within the blind spot.

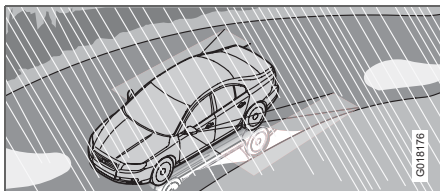

Reflection from shiny wet road surface.

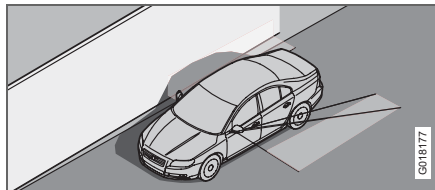

Own shadow on large, light, smooth surface, e.g. noise barrier or concrete road surface.

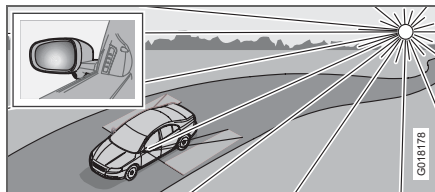

Low sun in the camera.

Towing and recovery

Never tow the car to bump start it

Jump start the car with a donor battery if the battery is flat and the engine does not start. Do not bump start the car.

IMPORTANT

Bump starting the car can damage the catalytic converter.

Towing

Find out the highest legal speed for towing before towing the car.

- Turn the ignition switch to position **II** and unlock the steering lock so that the car can be steered, see page 122.
- The ignition key must remain in position **II** while the car is being towed.

Automatic gearbox:

- Move the gear selector to position **N**.

Manual gearbox:

- Move gear lever into neutral.
- Ensure the towrope is always taut to avoid violent jerks. Keep your foot on the brake pedal.

Cars with automatic gearbox must not be towed at speeds above 80 km/h or further

than 80 km. The car must always be towed facing forward.

WARNING

The steering lock stays in the position it was in when the power was cut off. The steering lock must be unlocked before towing.

The ignition key must be in position **II**. Never remove the ignition key from the ignition switch while driving or when the car is being towed.

NOTE

If the car is de-energised then the steering lock must be unlocked using a donor battery before towing can be started.

WARNING

The brake servo and power steering do not work when the engine is switched off. The brake pedal must be pressed about five times harder than normal, and the steering will be considerable heavier than normal.

Towing eye

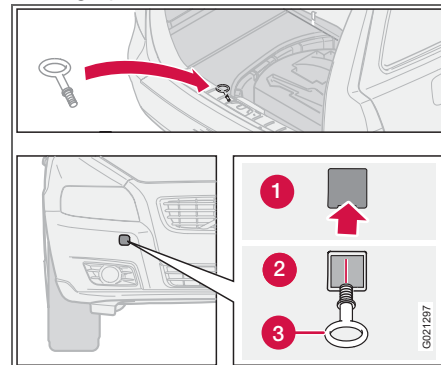

Use the towing eye if the car needs to be towed on the road. The towing eye is attached in the recess on the right-hand side of the front or rear bumper.

Fitting the towing eye

1. Take out the towing eye that is located under the floor hatch in the cargo area.
2. Release the cover (1) on the bumper by pressing on the marking on the lower edge of the cover.
3. Screw in the towing eye (3) firmly, right up to the flange. Use the wheel wrench to tighten the towing eye.

**Towing and recovery**

4. After use, unscrew the towing eye and return it in the cargo area. Refit the cover on the bumper.

**IMPORTANT**

The towing eye is only designed for towing on roads, not for pulling the car unstuck or out of a ditch. Call a recovery service for assistance.

**NOTE**

On certain cars with fitted towbar the towing eye cannot be secured in the rear mounting. In which case, secure the tow rope in the towbar.

For this reason it is advisable to store the towbar's towball in the car, see page 152.

Recovery

If only partially raised, cars with automatic gearbox must not be transported at speeds above 80 km/h or further than 80 km. During such transport, the wheels must always roll forward.



Start assistance

Starting with a donor battery

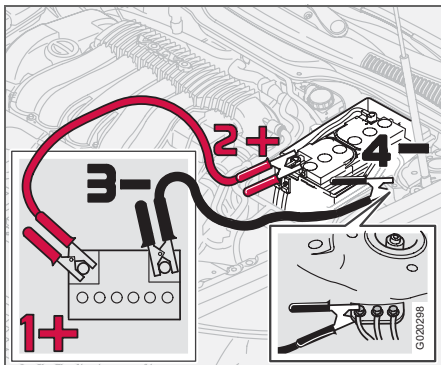

If the battery in the car has become flat, you can "borrow" electric current from either a separate battery or the battery in another car. Always make sure the crocodile clips on the jump leads are attached securely to eliminate sparks during the start attempt.

When jump starting the car, the following steps are recommended to avoid risk of explosion:

- Turn the ignition key to position **0**.
- Ensure that the other battery is 12 volt.
- If the donor battery is in another car, switch off the engine in the other car and

ensure that the cars do not touch one another.

- Connect the red jump lead between the positive terminal on the donor battery (1+) and the one on the battery of your car (2+).
- Connect one end of the black jump lead to the donor battery's negative terminal (3-).
- Connect the other end of the black jump lead to the earthing point (4-) by the left-hand strut tower.
- Start the engine of the "donor car". Let the engine run a few minutes at a speed slightly higher than idle 1500 rpm.
- Start the engine of the car with the flat battery.
- Remove the jump leads, first the black and then the red. Ensure that neither of the black jump lead's clips comes into contact with the battery's positive terminal or the crocodile clip on the red jump lead.



IMPORTANT

Do not touch the crocodile clips during the start procedure. This could cause sparking.



WARNING

The battery can generate oxyhydrogen gas, which is highly explosive. One spark, which can be generated if you connect the jump leads incorrectly, is sufficient to make the battery explode.

The battery contains sulphuric acid, which can cause serious burns. If the acid comes into contact with eyes, skin or clothing, flush with large quantities of water.

If acid splashes into the eyes, seek medical attention immediately.

**Driving with a trailer****General**

The load capacity is affected by extra accessories mounted on the car, such as a towbar, load carriers, space box, the passengers' combined weight etc. as well as the load on the towball. The load capacity of the car is reduced by the number of passengers and their weight.

If the towing bracket is fitted by an authorised Volvo workshop, then the car is delivered with the necessary equipment for driving with a trailer.

- The car's towing bracket must be of an approved type.
- If the towbar is retrofitted, check with your Volvo dealer that the car is fully equipped for driving with a trailer.
- Distribute the load on the trailer so that the weight on the towing bracket follows the specified maximum towball load.
- Increase the tyre pressure to the recommended pressure for a full load. For tyre pressure decal location, see page 162.
- Clean the towbar regularly and grease the towball¹.

- Do not tow a heavy trailer when the car is brand new. Wait until it has been driven at least 1000 km.
- The brakes are loaded much more than usual on long and steep downhill slopes. Downshift to a lower gear and adjust your speed.
- The engine is loaded more heavily than usual when driving with a trailer.
- The engine and gearbox can overheat if the car is driven with a heavy load in hot weather. If the temperature gauge for the engine's cooling system goes into the red zone, stop and let the engine idle for a few minutes. The automatic gearbox responds through a built-in protection system. See the message on the information display. If the car overheats, the air conditioning may be switched off temporarily.
- In the interests of safety, speed should be restricted to 80 km/h, even if the laws of certain countries allow for higher speeds.
- Move the gear selector to parking position **P** when parking an automatic car with a hitched trailer. Always use the parking brake. Block the wheels with chocks when parking a car with hitched trailer on a hill.

Trailer weights

Information on permitted trailer weights, see page 236.

**WARNING**

Follow the stated recommendations for trailer weights. Otherwise, the rig may be difficult to control during evasive manoeuvres and braking.

**NOTE**

The stated maximum permitted trailer weights are those permitted by Volvo. National vehicle regulations can further limit trailer weights and speeds. Towbars can be certified for higher towing weights than the car can actually tow.

¹ Does not apply to the towball if using a stabiliser hitch.



Driving with a trailer

Automatic gearbox, driving with a trailer

Parking on a hill

1. Apply the parking brake (handbrake).
2. Move the gear selector to parking position **P**.

Starting on a hill

1. Move the gear selector to driving position **D**.
2. Release the parking brake (handbrake).

Steep inclines

- Select an appropriate manual gear position when climbing steep inclines or at low speeds. This prevents the gearbox from changing up and keeps the gearbox oil cooler.
- Do not use a higher manual gear than the engine can "handle". It is not always economical to drive in high gears.
- Avoid driving with a trailer on inclines of more than 15 %.

Diesel 1.6D engine with manual gearbox, driving with a trailer

If the car is driven with a major load in a hot climate, the engine cooling fan can be replaced with one of a greater capacity than the standard model. Check with your nearest Volvo dealer regarding the options for your car.



Towing equipment

Towbars

The towball must be cleaned and greased regularly. If a towball hitch with vibration damper is used, it is not necessary to grease the towball.

If the car is equipped with a detachable towbar, the towball mounting instructions must be followed carefully, see page 149.

WARNING

Be sure to attach the trailer's safety cable to the correct place.

WARNING

If the car is fitted with a Volvo detachable towbar:

Follow the assembly instructions for the towball section carefully.

The towball section must be locked with the key before setting off.

Check that the indicator window shows green.

NOTE

Always take off the towball section after use. Keep it in the cargo area.

Trailer cable

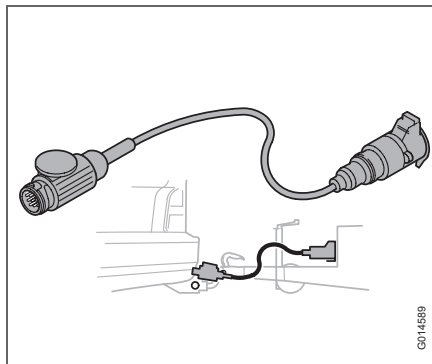

An adapter is required if the car's towbar has 13 pin electrics and the trailer has 7 pin electrics. Use an adapter cable approved by Volvo. Make sure the cable does not drag on the ground.



Towing equipment

Specifications

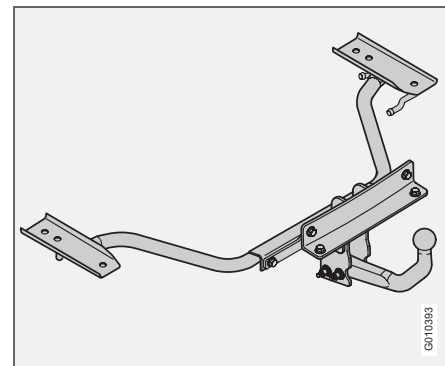
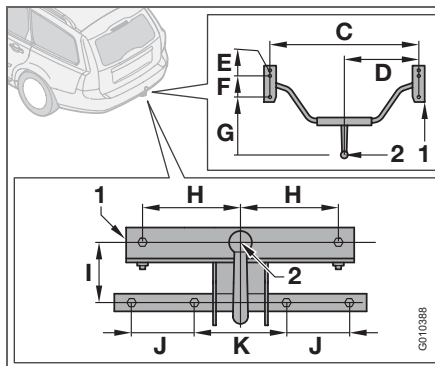
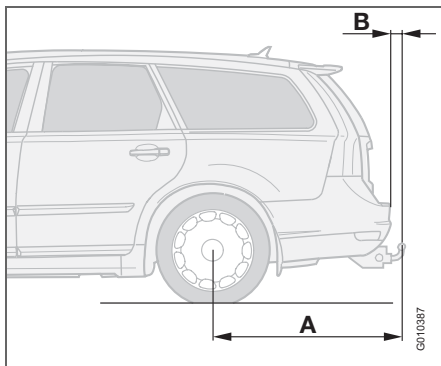

Dimensions for mounting points (mm)

	A	B	C	D	E	F	G	H	I	J	K
Fixed towbar standard	1104	90	964	482	40	141	542	150	63	100	140
Fixed towbar with Nivomat	1100	96									
Detachable towbar standard	1104	90	964	482	40	141	542	150	63	100	140
Detachable towbar with Nivomat	1100	96									
1	Side member										
2	Ball centre										

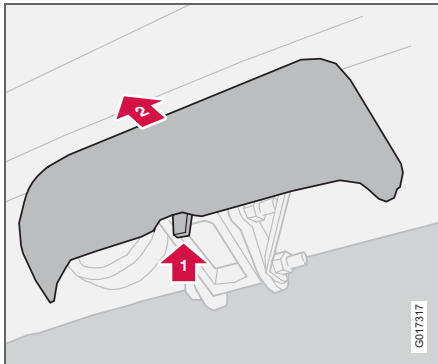
**Detachable towbar****Fitting the towball**

- Remove the protective cover

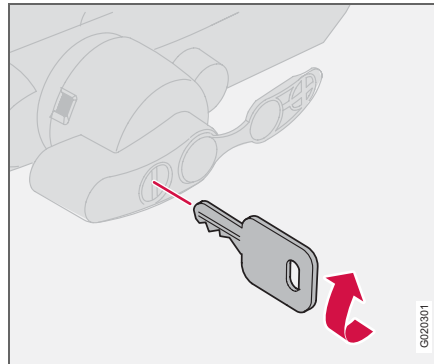

- Ensure that the mechanism is in the unlocked position by turning the key clockwise.

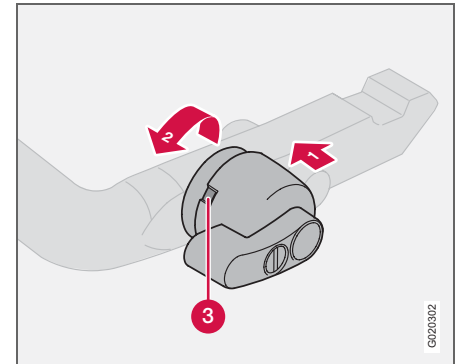

- Check that the indicator window (3) shows red. If the window does not show red, press in (1) and turn the locking wheel anticlockwise (2) until you hear a click.



Detachable towbar

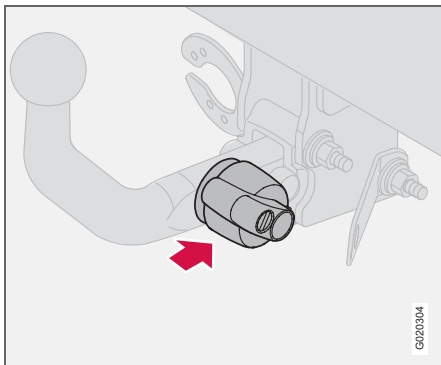

- Insert the towball section until you hear a click.

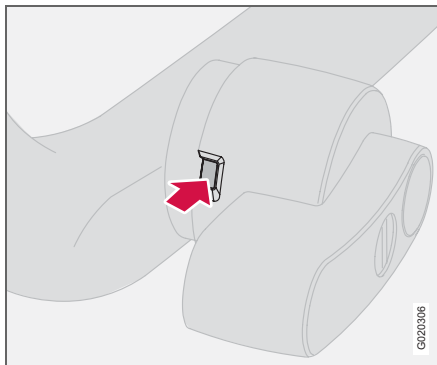

- Check that the indicator window shows green.

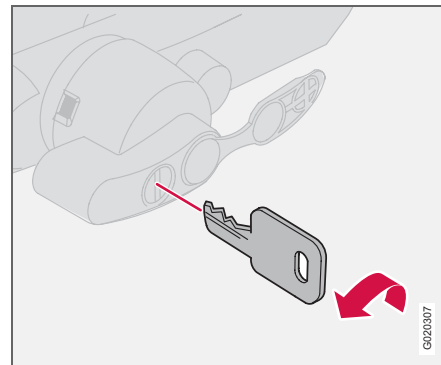

- Turn the key anticlockwise to the locked position. Remove the key from the lock.

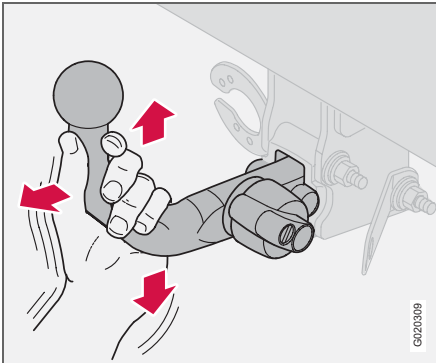

Detachable towbar

**i** NOTE

Check that the towball section is secure by pulling it up, down and back. If the towball section is not fitted correctly then it must be removed and refitted in accordance with the previous steps.

! IMPORTANT

Only grease in the towball for the towing hitch, the remainder of the towball section should be clean and dry.

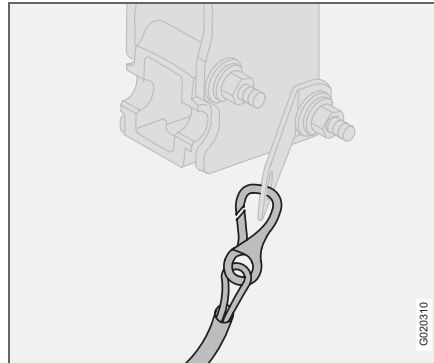
**i** NOTE

The trailer's safety cable must be secured in the towing bracket's mounting eye.



Detachable towbar

Removing the towball

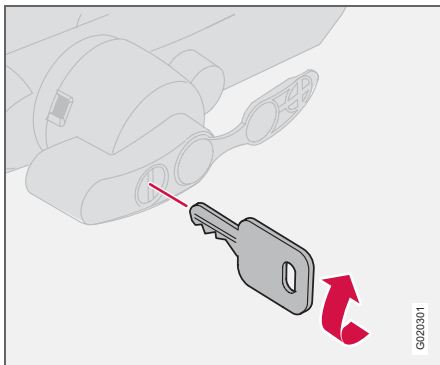

- Insert the key and turn it clockwise to the unlocked position.

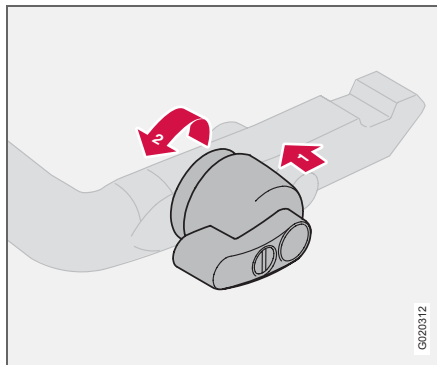

- Push in the locking wheel (1) and turn it anticlockwise (2) until you hear a click.

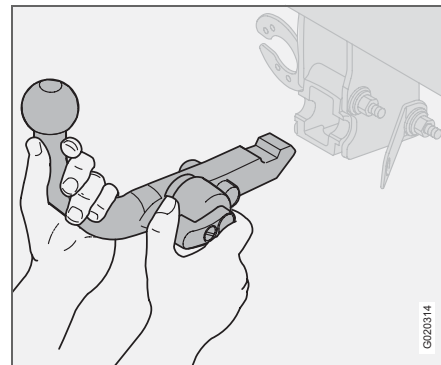

- Turn the locking wheel fully, until it comes to a stop. Hold it in this position while pulling the towball rearward and upward.



WARNING

Firmly secure the towbar's loose towball if it is stored in the car's cargo area.

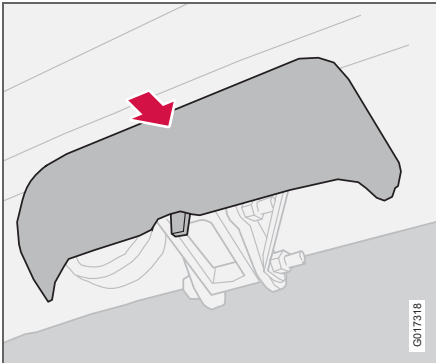
**Detachable towbar**

- Push on the protective cover.



Loading

General

The load capacity is affected by extra accessories mounted on the car, such as a towbar, load carriers, space box, the passengers' combined weight etc. as well as towball load. The load capacity of the car is reduced by the number of passengers and their weight. For information on permitted weights, see page 236.

WARNING

The car's driving characteristics change depending on how heavily it is loaded and how the load is distributed.

Loading the cargo area

Stop the engine and apply the parking brake when loading or unloading long objects. The gear lever or gear selector could be knocked out of position by long loads, which could set the car in motion.

To increase the size of the cargo area, the head restraints can be removed and the seats folded down, see page 92.

Place the load firmly against the backrest in front.

- The head rests can be removed so that they are not damaged.

- Put wide loads in the centre.
- Heavy objects should be placed as low as possible. Avoid placing heavy loads on a lowered backrest.
- Cover sharp edges with something soft to avoid damaging the upholstery or the large glass surface of the tailgate.
- Secure all loads to the load retaining eyelets with straps or web lashings.

WARNING

A loose object weighing 20 kg can, in a frontal collision at a speed of 50 km/h, carry the impact of an item weighing 1000 kg.

WARNING

Never load cargo above the backrest. The protection provided by the inflatable curtain in the headlining may be compromised or eliminated by high loads. Always secure the load. During heavy braking the load may otherwise shift, causing personal injury.

Load carriers

To avoid damaging the car and for maximum possible safety while driving, it is recommended to use load carriers specially designed for your car by Volvo.

Carefully follow the mounting instructions supplied with the carriers.

- Check periodically that the load carriers and load are properly secured. Lash the load securely with retaining straps.
- Distribute the load evenly over the load carriers. Put the heaviest objects at the bottom.
- The size of the area exposed to the wind, and therefore fuel consumption, increase with the load's size.
- Drive gently. Avoid quick accelerations, heavy braking and taking curves hard.

WARNING

The car's centre of gravity and driving characteristics are altered by roof loads.



Adjusting headlamp pattern

Correct light pattern for left or right-hand traffic

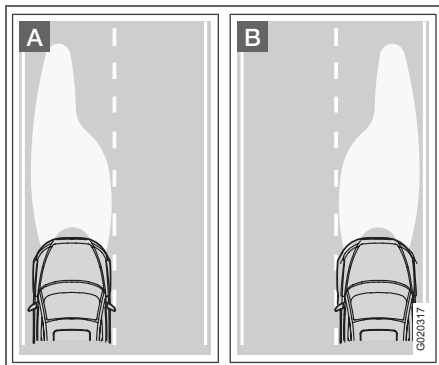

A. Headlamp pattern for left-hand traffic
B. Right-hand traffic

The headlamps' projection can be adjusted to avoid dazzling other motorists. The correct pattern will also better illuminate the verge.

Halogen headlamps

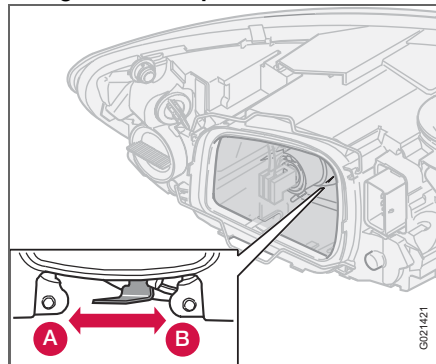

The headlamp control should be in position (A) for left-hand traffic and position (B) for right-hand traffic.

Bi-Xenon headlamps

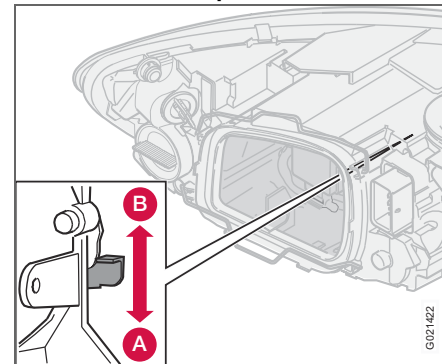

The headlamp control should be in position (A) for left-hand traffic and position (B) for right-hand traffic.

WARNING

On cars with Bi-Xenon headlamps the replacement must be carried out by an authorised Volvo workshop. The headlamps must be handled with extreme care due to the high-voltage unit in the Xenon lamp.



General	158
Tyre pressure	162
Warning triangle and spare wheel	164
Changing wheels	165
Emergency puncture repair	167

WHEELS AND TYRES



07

General

Driving characteristics and tyres

The tyres greatly affect the car's driving characteristics. The type of tyre, dimensions, tyre pressure and speed rating are important for how the car performs.

When changing tyres, ensure that tyres of the same type and dimensions, and preferably also the same make, are fitted to all four wheels. Follow the recommended tyre pressures specified on the tyre pressure label, see page 162.

Designation of dimensions

The dimensions are stated on all car tyres. Example: 205/55R16 91 W.

205	Section width (mm)
55	Ratio between section height and width (%)
R	Radial ply
16	Rim diameter in inches (")
91	Tyre load index (in this case 615 kg)
W	Speed rating (in this case 270 km/h).

Speed ratings

The car has "Whole Vehicle Type Approval", which means that dimensions and speed ratings must not differ from those specified on the vehicle's registration document. The only exception to these conditions is winter tyres (both those with studs and those without). If such a tyre is chosen, the car must not be driven faster than the speed rating of the tyre (for example, class Q can be driven at a maximum of 160 km/h).

Remember that traffic regulations determine how fast a car can be driven, not the speed class of the tyres.

Note! Maximum permitted speeds indicated.

Q	160 km/h (used only on winter tyres)
T	190 km/h
H	210 km/h
V	240 km/h
W	270 km/h
Y	300 km/h

New tyres

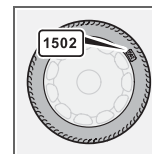

Tyres are perishable. After a few years they begin to harden at the same time as the friction capacity/ characteristics gradually deteriorate. Therefore aim to get as fresh tyres as possible when you replace them. This is especially important with regard to winter tyres.

The week and year of manufacture, the tyre's DOT marking (Department of Transportation), are stated with four digits, for example 1502. The tyre in the illustration was manufactured in week 15 of 2002.

Tyre age

All tyres older than six years should be checked by an expert even if they seem undamaged. The reason for this is that tyres age and decompose, even if they are hardly ever or never used. The function can therefore be affected due to the tyre's constituent materials being broken down. In such a case the tyre should then not be used. This also applies to spare tyres, winter tyres and tyres saved for future use. Examples of external signs which indicate that the tyre is unsuitable for use are cracks or discoloration.

The age of the tyre can be determined by the DOT marking, see illustration above.



More even wear and maintenance



The correct tyre pressure results in more even wear, see page 163. To achieve the best traction and more even wear on the tyres, the regular switching of the front and rear tyres with each other is recommended. The first change should be after 5000 km and then at intervals of 10000 km, this is to avoid differences in tread depth. Tyres with the greatest tread depth should always be fitted to the rear wheels to decrease the risk of skidding. Contact an authorised Volvo workshop for an inspection if you are uncertain about tread depth.

Wheels should be stored lying down or hanging up, and not standing up.

Tyres with tread wear indicators

Tread wear indicators are narrow treadless bands across the width of the tread. On the side of the tyre are the letters TWI (Tread Wear Indicator). When the tyre's tread depth is down to 1.6 mm, the tread depth will be level in height with the tread wear indicators. Change to new tyres as soon as possible. Remember that tyres with little tread depth provide very poor grip in rain and snow.

Winter tyres

Volvo recommends winter tyres with particular dimensions. These are stated on the tyre pressure label, see page 162 for its location. The tyre dimensions are dependent on the engine variant. When driving on winter tyres, these must be fitted to all four wheels.

i NOTE

Ask a Volvo dealer which rim and tyre types are most suitable.

Studded tyres

Studded winter tyres should be run in gently for 500–1000 km so the studs settle properly into the tyres. This gives the tyres, and especially the studs, a longer lifespan.

i NOTE

The legal provisions for the use of studded tyres vary from country to country.

Tread depth

Road conditions with ice, slush and low temperatures place considerably higher demands on tyres than summer conditions. It is therefore not recommended to drive on winter tyres that have a tread depth of less than four millimetres.

Snow chains

Snow chains may only be used on the front wheels. This also applies to all-wheel-drive cars.

Never drive faster than 50 km/h with snow chains. Avoid driving on bare ground as this wears out both the snow chains and tyres. Never use quick-fit snow chains as the space between the brake discs and the wheels is too small.

! IMPORTANT

Use Volvo genuine snow chains or equivalent chains designed for the car model, and tyre and rim dimensions. Consult an authorised Volvo workshop.



General

Rims and wheel nuts

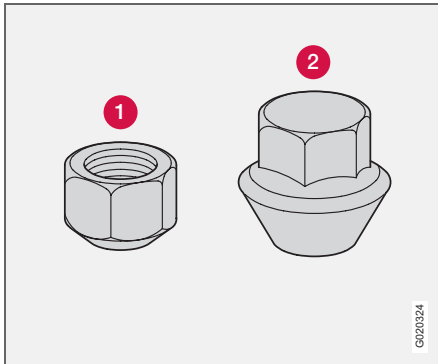

Standard (1) and bulge acorn (2) wheel nuts

Only use rims that are tested and approved by Volvo and which are Volvo genuine accessories. There are two types of wheel nut, depending on whether the rims are made of steel or aluminium. Tighten the wheel nuts to 130 Nm. Check the torque with a torque wrench.

IMPORTANT

The wheel nuts should be tightened to 130 Nm. Overtightening can damage the nuts and the bolts.

Steel rims – standard wheel nuts (1)

Steel rims are normally mounted with the standard wheel nuts, but the bulge acorn variety may also be used.

WARNING

Never use standard nuts for aluminium rims. The wheels can come loose.

Aluminium rims – bulge acorn wheel nuts (2)

Only use the bulge acorn variety of nuts with aluminium rims. These differ markedly from other nut types as they have a rotating conical washer.

NOTE

These nuts may also be used with steel rims.

Locking wheel nuts

Locking wheel nuts can be used on both aluminium and steel rims. If steel rims with locking nuts are used in combination with wheel covers, the locking wheel nut should be mounted on the bolt nearest the air valve. Otherwise the wheel cover cannot be fitted to the rim.

Spare wheel Temporary Spare

The spare wheel¹ is only intended to be used for the short time it takes to get the ordinary wheel replaced or repaired. Replace the spare wheel as soon as possible with a normal wheel. The car's handling may be altered by the use of the spare wheel.

Never drive faster than 80 km/h with a spare wheel on the car.

IMPORTANT

The car must never be driven fitted with more than one "Temporary Spare" wheel.

¹ Certain variants and markets



Summer and winter wheels

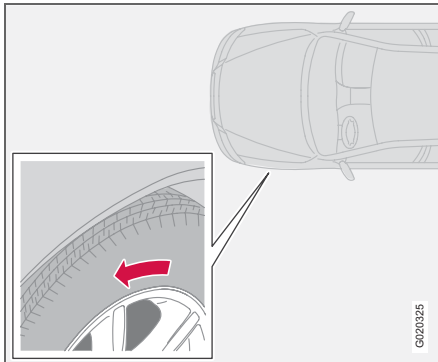

The arrow shows the tyre's direction of rotation

When summer and winter wheels are changed they should be marked with which side of the car they were mounted on, for example **L** for left and **R** for right. Tyres with tread patterns which are designed to only rotate in one direction have the direction of rotation marked with an arrow on the tyre.

The tyre should always rotate in the same direction throughout its lifespan. Tyres should only be switched between front and rear positions, never between left and right-hand sides, or vice versa.

If the tyre is mounted incorrectly, the car's braking characteristics and capacity to force rain, snow and slush out of the way are adversely affected.

Tyres with the greatest tread depth should always be fitted to the rear of the car (to decrease the risk of skidding).

Wheels should be stored lying down or hanging up, and not standing up.

Contact an authorised Volvo workshop if you are uncertain about tread depth.

Tyre pressure

Recommended tyre pressure

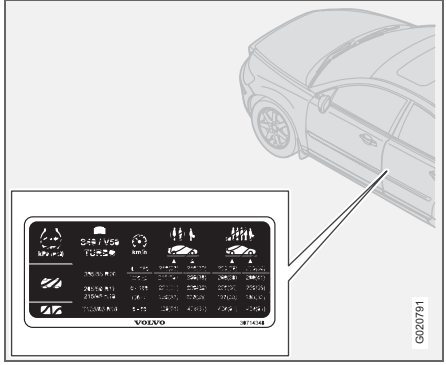

The tyre pressure label on the driver's side door pillar shows which pressures the tyres should have at different load and speed conditions.

Stated on the decal:

- Tyre pressure for the car's recommended wheel size
- ECO pressure
- Spare wheel pressure (Temporary Spare).

Checking the tyre pressure

Check the tyre pressure regularly.

NOTE

Tyre pressure decreases over time, this is a natural phenomenon. Tyre pressure also varies depending on ambient temperature.

Even after several kilometres of driving the tyres warm up and the pressure increases, so air must not be released if the pressure is checked when the tyres are warm, while the pressure must be increased if it is too low.

Inadequately inflated tyres increase fuel consumption, shorten tyre lifespan and impair the car's roadholding. Driving on tyres with tyre pressure that is too low could also result in the tyres overheating and disintegrating.

For information on the correct tyre pressure, refer to the tyre pressure table on page 163. The specified tyre pressures refer to "cold tyres". ("Cold tyres" means the tyres are the same temperature as the ambient temperature.)

Fuel economy, ECO pressure

At speeds under 160 km/h, the general tyre pressure for full load is recommended in order to obtain optimum fuel economy.

Tyre pressure affects travelling comfort, road noise and steering characteristics.



Tyre pressure

Tyre pressure table

Variant	Tyre size	Speed (km/h)	Load, 1-3 persons		Max. load	
			Front (kPa) ¹	Rear (kPa)	Front (kPa)	Rear (kPa)
1.6	195/65 R15 91V	0-160	210	210	250	250
1.8	205/55 R16 91V/W	160+	250	210	280	260
2.0	195/65 R15 91Q/T/H/V M+S					
1.6D	205/55 R16 91Q/T/H/V M+S					
	205/50 R17 93W Extra Load	0-160	220	220	250	250
	215/45 R18 93W Extra Load	160 +	260	220	280	260
	205/50 R17 93Q/T/H/V M+S Extra Load					
2.4	205/55 R16 91W	0-160	210	210	250	250
2.4i	205/55 R16 91Q/T/H/V M+S	160+	250	210	280	260
2.0D	205/50 R17 93W Extra Load	0-160	220	220	250	250
	215/45 R18 93W Extra Load	160+	260	220	280	260
	205/50 R17 93Q/T/H/V M+S Extra Load					
T5	205/55 R16 91W	0-160	210	210	250	250
	205/55 R16 91Q/T/H/V M+S	160+	260	210	280	260
	205/50 R17 93W Extra Load	0-160	220	220	250	250
	215/45 R18 93W Extra Load	160+	270	220	290	270
	205/50 R17 93Q/T/H/V M+S Extra Load					
D5	205/55 R16 91 V/W	0-160	230	220	250	250
	205/50 R17 93W Extra Load	160+	270	220	290	270
	215/45 R18 93W Extra Load					
	205/55 R16 91Q/T/H/V M+S					
	205/50 R17 93Q/T/H/V M+S Extra Load					
All	All	0-160	250 ²	250 ²	250 ²	250 ²
Spare wheel ³	T125/85R16 99M	0-80	420	420	420	420

¹In certain countries there is the "bar" unit beside the SI unit "Pascal": 1 bar = 100 kPa

²ECO pressure page 162

³Temporary Spare

Warning triangle and spare wheel

Warning triangle

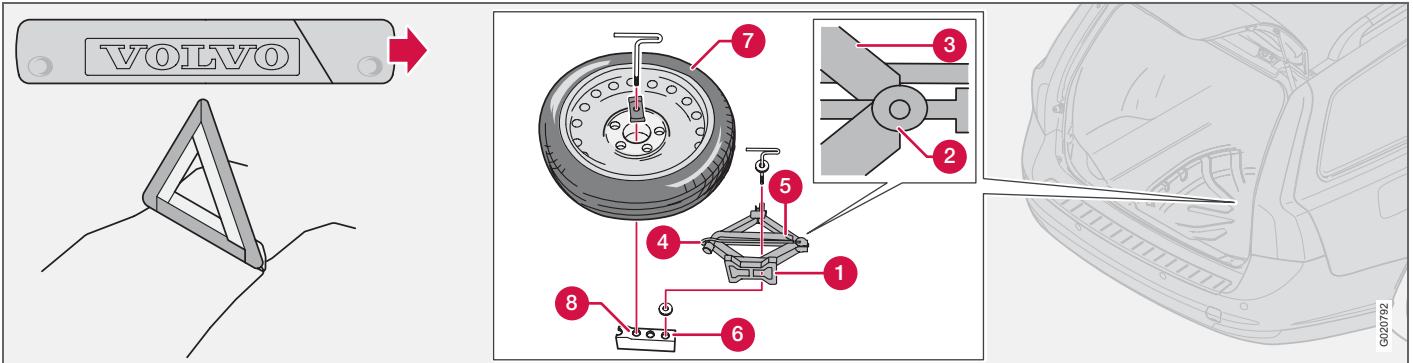

Follow the regulations for the use of a warning triangle¹. Place the warning triangle in a suitable place with regard to the traffic.

- Undo the case containing the warning triangle, it is attached with Velcro. Take the warning triangle out of the case.
- Lower the warning triangle's support legs. Ensure the warning triangle and its case are properly secured in the cargo area after use.

Spare wheel and jack

The car's original jack

The original jack² should only be used for changing wheels. The jack's thread should always be well greased. Spare wheel with jack and wheel wrench are located under the floor in the cargo area.

Taking out the spare wheel:

- Fold the rear edge of the floor mat forward.

- Release the spare wheel and lift it out.
- Take out the jack and the wheel wrench.

Putting the spare wheel and jack into the cargo area:

- Crank the jack (1) to halfway. The marking on the plate (2) should line up with the marking on the arm (3) so that the jack can fit lying down in the holder.
- Fold in the handle (4) and place the wheel wrench (5) on the jack.
- Put the jack (1) back in the hole on the right (6). Fasten the spare wheel (7) in the hole on the left (8).

¹ Certain markets

² Certain variants and markets



Changing wheels

Removing wheels

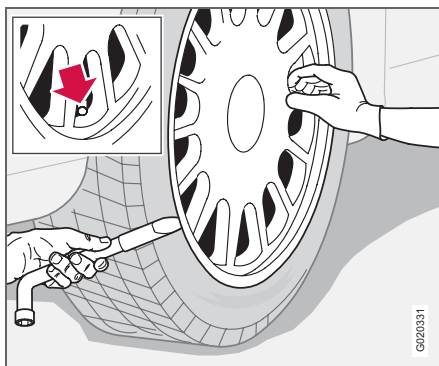

Set up the warning triangle if a wheel must be replaced at a busy location. Make sure that the car and jack are on a firm horizontal surface.

- Take out the spare wheel, jack and wheel wrench, which are found under the carpet in the cargo area.
- Apply the parking brake and engage first gear, or position **P** if the car has an automatic gearbox.
- Place chocks in front of and behind the wheels which will remain on the ground. Use heavy wooden blocks or large stones.

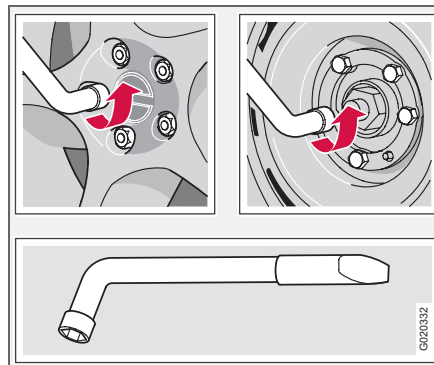

- Cars with steel rims have removable wheel covers. Prize off the wheel cover with the end of the wheel wrench, or pull it off by hand.
- Loosen the wheel nuts $\frac{1}{2}$ –1 turn anticlockwise with the wheel wrench.

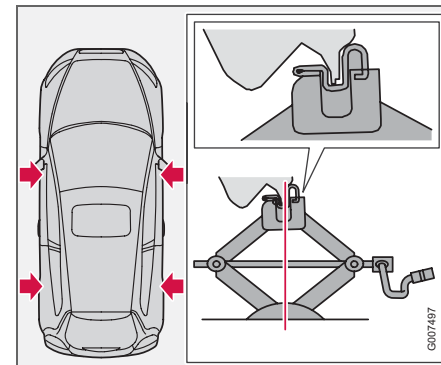

- Two jacking points are located on each side of the car. Wind down the jack's base so that it sits level on the ground. Check that the jack is seated correctly in the jacking point, as illustrated, and that the base is located directly under it.
- Jack up the car high enough that the wheel is clear of the ground. Remove the wheel nuts and lift off the wheel.



Changing wheels

Fitting the wheel

- Clean the contact surfaces on the wheel and hub.
- Put on the wheel. Tighten the wheel nuts.
- Lower the car so that the wheel cannot rotate.
- Tighten the wheel nuts crosswise. It is important that the wheel nuts are tightened properly. Tighten to 130 Nm. Check the torque with a torque wrench.
- Put on the wheel cover (steel rim).



WARNING

Never crawl under the car when it is raised on the jack.

Passengers must leave the car when it is raised on the jack.

Ensure that passengers wait with the car - or preferably a crash barrier - between them and the road.

**Emergency puncture repair****General**

The emergency puncture repair kit¹ is used to seal the puncture and to check and adjust the tyre pressure. It consists of a compressor and a bottle with sealing fluid. The kit works as a temporary repair. The sealing fluid bottle must be replaced before its expiration date and after use.

The sealing fluid effectively seals tyres punctured in the tread.

i NOTE

The emergency puncture repair kit is only intended for sealing tyres with a puncture in the tread.

i NOTE

The jack is an option on cars equipped with emergency puncture repair kit.

The emergency puncture repair kit has limited abilities to seal tyres which have punctures in the wall of the tyre. Do not seal tyres with the emergency puncture repair kit if they have larger slits, cracks or similar damage.

12 V sockets for the compressor are located by the centre console in the front, by the rear

¹ Certain variants and markets

seat and in the cargo/luggage area². Choose the electrical socket that is nearest the punctured tyre.

⚠ WARNING

You must not drive faster than 80 km/h after the emergency tyre repair kit has been used. Contact an authorised Volvo workshop for inspection of the sealed tyre (maximum driving distance is 200 km). The staff there can determine whether or not the tyre can be repaired or if it needs to be replaced.

Taking out the emergency puncture repair kit

The emergency puncture repair kit with compressor and tools are found under the floor in the cargo area.

- Fold away the rear edge of the floor mat, forward from the back.
- Lift up the emergency puncture repair kit.

² Option



Emergency puncture repair

Overview

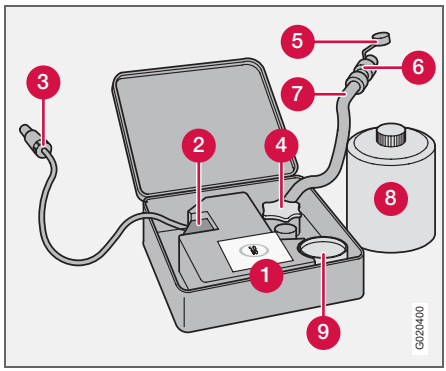

- 1. Decal, maximum permitted speed
- 2. Switch
- 3. Cable
- 4. Bottle holder (orange cap)
- 5. Protective cap
- 6. Pressure reducing valve
- 7. Air hose
- 8. Sealing fluid bottle
- 9. Pressure gauge

Inflating the tyres

The car's original tyres can be inflated by the compressor.

- The compressor must be switched off. Make sure that the switch is in position **0** and locate the cable and air hose.
- Unscrew the wheel's dust cap and screw in the air hose valve connection to the bottom of the thread on the tyre's air valve.
- Connect the cable to one of the car's 12 V sockets and start the car.

⚠ WARNING

Inhaling car exhaust fumes can result in danger to life. Never leave the engine running in enclosed areas or areas that lack sufficient ventilation.

- Start the compressor by flicking the switch to position **I**.
- Inflate the tyre to the pressure specified on the tyre pressure decal. (Release air using the pressure reducing valve if the tyre pressure is too high.)

⚠ IMPORTANT

Risk of overheating. The compressor must not run for more than 10 minutes.

- Switch off the compressor. Detach the air hose and cable.
- Refit the dust cap.



Emergency puncture repair

Sealing punctured tyres

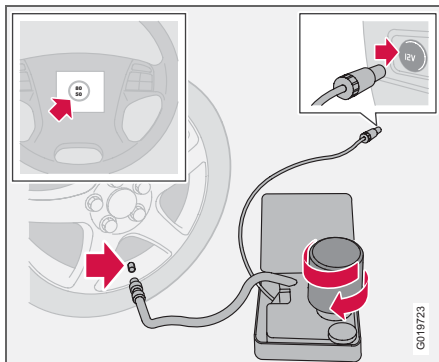

For information on the function of the parts, see the illustration on page 168.

- Open the lid of the emergency puncture repair kit.
- Detach the decal for maximum permitted speed and affix it to the steering wheel.
- Check that the switch is in position **0** and locate the cable and the air hose.

WARNING

The sealing fluid can irritate the skin. In the case of contact with skin, wash away the fluid with soap and water.

- Unscrew the orange cap and unscrew the bottle's stopper.

NOTE

Do not break the bottle seal. The seal is broken when the bottle is screwed in.

- Screw the bottle into its holder.

WARNING

Do not unscrew the bottle, it is equipped with a reverse catch to prevent leakage.

- Unscrew the wheel's dust cap and screw in the air hose valve connection to the bottom of the thread on the tyre's air valve.
- Plug the cable into the 12 V socket and start the car.
- Flick the switch to position **I**.

WARNING

Never stand next to the tyre when the compressor is running. If cracks or unevenness arise then the compressor must be switched off immediately. The journey should not be continued. Contact an authorised tyre centre.

NOTE

When the compressor starts, the pressure can increase up to 6 bar but the pressure drops after approximately 30 seconds.

- Inflate the tyre for 7 minutes.

IMPORTANT

Risk of overheating. The compressor must not run for more than 10 minutes.

- Switch off the compressor to check the pressure on the pressure gauge. Minimum pressure is 1.8 bar and maximum is 3.5 bar.

WARNING

If the pressure is below 1.8 bar then the hole in the tyre is too big. The journey should not be continued. Contact an authorised tyre centre.

- Switch off the compressor and unplug the cable from the 12 V socket.
- Detach the hose from the tyre valve and fit the valve cap.
- As soon as possible, drive approximately 3 km at a maximum speed of 80 km/h so that the sealing fluid can seal the tyre.



Emergency puncture repair

Rechecking the repair and pressure

- Reconnect the equipment.
- Read the tyre pressure on the pressure gauge.
- If it is below 1.3 bar then the tyre is insufficiently sealed. The journey should not be continued. Contact a tyre centre.
- If the tyre pressure is higher than 1.3 bar, the tyre must be inflated to the pressure specified on the tyre pressure decal. Release air using the pressure reducing valve if the tyre pressure is too high.
- Switch off the compressor. Detach the air hose and cable. Refit the dust cap.

WARNING

Do not unscrew the bottle, it is equipped with a reverse catch to prevent leakage.

- Return the emergency puncture repair kit to the cargo area.

NOTE

The sealing fluid bottle and hose must be replaced after use. Replacement must be performed by an authorised Volvo workshop.

WARNING

Check the tyre pressure regularly.

- Drive to the nearest authorised Volvo workshop for the replacement/repair of the damaged tyre. Advise the workshop that the tyre contains sealing fluid.

WARNING

You must not drive faster than 80 km/h after the emergency tyre repair kit has been used. Contact an authorised Volvo workshop for inspection of the sealed tyre (maximum driving distance is 200 km). The staff there can determine whether or not the tyre can be repaired or if it needs to be replaced.

Changing the sealing fluid canister

Replace the bottle before the expiration date has passed. Treat the old bottle as environmentally hazardous waste.

IMPORTANT

Read the safety instructions on the bottom of the bottle.





Cleaning	174
Touching up paintwork	177
Rustproofing	178

CAR CARE



08

Cleaning

Washing the car

Wash the car as soon as it becomes dirty. Use car shampoo. Dirt and road salt can lead to corrosion.

- Do not park the car in direct sunshine. Washing a car with hot paintwork can cause permanent paintwork damage. Wash the car in a car wash with waste water separator.
- Thoroughly rinse dirt off the underbody of the car.
- Rinse the entire car to remove loose dirt. When using a pressure washer: Make sure that the nozzle of the pressure washer is not closer than 30 cm to the bodywork. Do not spray directly at the locks.
- Wash using a sponge, car shampoo and plenty of lukewarm water.
- If the dirt is difficult to dislodge, wash the car using a cold degreasing agent.
- Dry the car using a clean, soft chamois or a water scraper.
- Clean the wiper blades with a lukewarm soap solution or car shampoo.

WARNING

Always have the engine cleaned by a workshop. There is a risk of fire if the engine is hot.

NOTE

Outside lighting such as headlamps, fog lamps and rear lamps may temporarily have condensation on the inside of the lens. This is a natural phenomenon, all outside lighting is designed to withstand this. Condensation is normally vented out of the lamp when it has been switched on for a time.

Removing bird droppings

Wash bird droppings off the paintwork as soon as possible. Bird droppings contain chemicals that affect and discolour paintwork very quickly. This discoloration can only be removed by a specialist.

Chromed wheels

IMPORTANT

Rim cleaning agents can cause stains on chrome-plated wheels. Wash using a sponge, car shampoo and plenty of lukewarm water.

Automatic car washes

An automatic car wash is a simple and quick way of washing the car, but it can never replace a proper handwashing. The brushes of an automatic car wash cannot reach everywhere.

WARNING

Always test the brakes after washing the car, including the parking brake, to ensure that moisture and corrosion do not attack the brake linings and reduce braking performance.

IMPORTANT

Washing by hand is gentler to the paintwork than an automatic car wash. Paintwork is also more sensitive when it is new. For this reason, handwashing is recommended during the first few months with a new car.

Press the brake pedal lightly from time to time if driving for long periods in rain or slush. This heats and dries the brake pads. You should also do this when you begin driving in extremely damp or cold weather.

Exterior plastic, rubber and trim components

A special cleaning agent available from Volvo dealers is recommended for cleaning coloured plastic parts, rubber and trim components (such as glossy trim mouldings). When using such a cleaning agent the instructions must be followed carefully.



Cleaning

IMPORTANT

Avoid waxing and polishing on plastic and rubber.

Polishing glossy trim mouldings could wear away or damage the glossy surface.

Polishing agent that contains abrasive must not be used.

Polishing and waxing

Polish and wax the car if the paintwork is dull or to give the paintwork extra protection.

The car does not need to be polished until it is at least one year old. However, the car can be waxed during this time. Do not polish or wax the car in direct sunlight.

Wash and dry the car thoroughly before you begin polishing or waxing. Clean off asphalt and tar stains using Volvo tar remover or white spirit. More stubborn stains can be removed using fine rubbing paste designed for car paintwork.

Polish first with a polish and then wax with liquid or solid wax. Follow the instructions on the packaging carefully. Many preparations contain both polish and wax.

IMPORTANT

Paint treatment such as preserving, sealing, protection, lustre sealing or similar could damage the paintwork. Paintwork damage caused by such treatment is not covered by Volvo warranty.

Cleaning door mirrors and front door windows with water-repellent coating (option)

Never use products such as car wax, degreaser or similar on mirror/glass surfaces as this could ruin their water-repellent properties.

Take care when cleaning so as not to damage the glass surface.

To avoid damaging glass surfaces when removing ice – only use plastic ice scrapers.

There is natural wear of the water-repellent coating.

Treatment with a special finishing agent available from Volvo dealers is recommended in order to maintain the water-repellent properties. This should be used first after three years and then each year.



Cleaning

Cleaning the interior

Treating stains on fabric upholstery

A special cleaning agent, available from Volvo dealers, is recommended for cleaning the fabric upholstery. Other chemicals can impair the fire retardant qualities of the upholstery.

IMPORTANT

Sharp objects and Velcro may damage the fabric upholstery.

Treating stains on leather upholstery

Volvo leather upholstery is chromium-free and approved in accordance with the Öko-TEX 100 standard.

The leather is refined and processed so that it retains its natural characteristics. It is given a protective coating, but regular cleaning is required in order to maintain both characteristics and appearance. Volvo offers a comprehensive product for the cleaning and treatment of leather upholstery which, when used in accordance with the instructions, preserves the leather's protective coating.

After a period of use the natural appearance of the leather will nevertheless emerge, depending more or less on the surface

texture of the leather. This is a natural maturing of the leather and shows that it is a natural product.

To achieve best results Volvo recommends cleaning and application of the protective cream once to four times per year (or more if required). Ask a Volvo dealer about Volvo's Leather care product.

IMPORTANT

Never use strong solvents. Such products may damage fabric, vinyl and leather upholstery.

IMPORTANT

Note that materials with colour that runs when dry (new jeans, suede garments etc.) may discolour the upholstery material.

Washing instructions for leather upholstery

- Pour the leather cleaner on the dampened sponge and squeeze out a strong foam.
- Work the dirt away with gentle circular movements.
- Dab with the sponge accurately on the stains. Allow the sponge to absorb the stain. Do not rub.

- Wipe off with soft paper or a cloth and allow the leather to dry completely.

Protective treatment of leather upholstery

- Pour a small amount of the protective cream on the felted cloth and massage in a thin layer of cream with gentle circular movements on the leather.
- Allow the leather to dry for 20 minutes before use.

The leather has now been given improved protection against stains and improved UV protection.

Treating stains on interior plastic, metal and wood parts

A special cleaning agent, available from Volvo dealers, is recommended for cleaning interior parts and surfaces. Do not scrape or rub stains. Never use strong stain removers.

Cleaning seatbelts

Use water and a synthetic detergent. A special textile cleaning agent is available from your Volvo dealer. Make sure the seatbelt is dry before allowing it to retract.



Touching up paintwork

Paintwork

Paint is an important part of the car's rust-proofing and should therefore be checked regularly. To avoid the onset of rust, damaged paintwork must be rectified immediately. The most common types of paintwork damage are stone chips, scratches, and marks on the edges of wings and doors.

Colour code

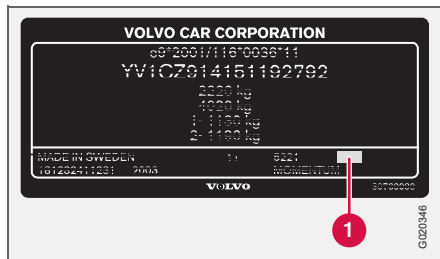

Data plate

It is important that the correct colour is used. The colour code number (1) is shown on the data plate, see page 234.

Stone chips and scratches

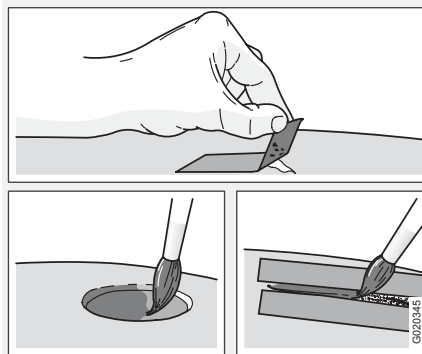

Before touching up paintwork, the car must be clean and dry and at a temperature above 15 °C.

Materials

- Primer in a can
- Paint in a can or touch-up pen
- Brush
- Masking tape

Minor stone chips and scratches

If the stone chip has not penetrated to the bare metal and there is an undamaged colour coat, you can paint straight after cleaning the damaged area.

If the stone chip has penetrated to the bare metal

- Stick a piece of masking tape over the damaged surface. Then remove the tape to remove any loose paint.
- Stir the primer well and apply using a fine brush or matchstick. Apply paint using a brush once the primer is dry.
- For scratches, proceed as above, but mask around the damaged area to protect the undamaged paintwork.
- After a few days, polish the touched-up areas. Use a soft rag and a small amount of lapping paste.



Rustproofing

Inspection and maintenance

Your car received a thorough and complete rustproofing at the factory. Parts of the body are made of galvanised sheet metal. The underbody is protected by a wear-resistant anti-corrosion compound. And, a thin, penetrating rustproofing fluid was sprayed into the members, cavities and closed sections.

Maintain the car's rustproofing.

- Keep the car clean. Hose down the underbody. If using a pressure washer, keep the nozzle at least 30 cm from the painted surfaces.
- Regularly check and touch-up the rustproofing treatment as necessary.

The car's rustproofing does not normally require treatment for approximately 12 years. After that time, it should be treated at three-year intervals. If the car needs further treatment, please contact an authorised Volvo workshop.



Empty rectangular box for text input.

Volvo service	182
Self-maintenance	183
Bonnet and engine compartment	184
Diesel	185
Oils and fluids	186
Wiper blades	191
Battery	192
Replacing bulbs	194
Fuses	201

MAINTENANCE AND SERVICE

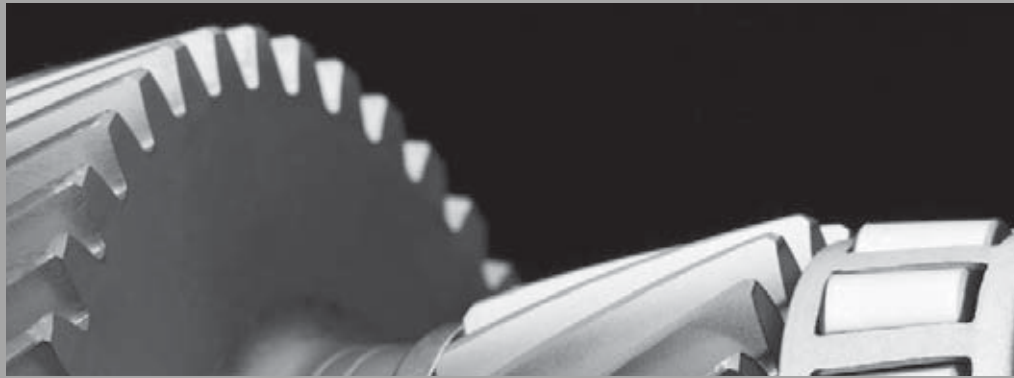

09



Volvo service

Volvo service programme

Before the car left the factory, it was thoroughly test driven. It was checked again in accordance with Volvo Car Corporation regulations before it was handed over to you.

To keep your Volvo as safe and reliable as possible, follow the Volvo service programme specified in the Service and Warranty Booklet. Have an authorised Volvo workshop carry out service and maintenance work. Volvo workshops have the personnel, special tools and service literature to guarantee the highest quality of service.



IMPORTANT

For the Volvo warranty to apply, check and follow the instructions in the Service and Warranty Booklet.

Special service measures

Certain service measures, which affect the car's electrical system, can only be performed using electronic equipment specially developed for your car. Always contact an authorised Volvo workshop before beginning or performing service work that affects the electrical system.

Installing accessories

The incorrect connection and installation of accessories can negatively affect the car's electrical system. Certain accessories only function when the appropriate software has been programmed into the car's electrical system. Always contact an authorised Volvo workshop before installing accessories which are connected to or affect the electrical system.

Recording vehicle data

One or more of the computers in your Volvo are capable of recording detailed information. This information is intended for use in research to enhance safety and for diagnosing faults in some of the in-car systems. The data may include details regarding seatbelt use by the driver and passengers, the functions of various vehicle systems and modules, and status information about the engine, throttle, steering, brakes and other systems. This data can also include details of the way the car is driven. This type of information can include, without being limited to, specific details such as vehicle speed, the use of the brake and accelerator pedals and steering wheel position. This latter type of data can be stored for a limited period while the car is being driven and subsequently during a collision or a near-collision. Volvo

Car Corporation will not disclose the stored information without consent. However, Volvo Car Corporation may be forced to disclose the information due to national legislation. Volvo Car Corporation and authorised Volvo workshops may also read and use the information.

Adverse driving conditions

Check the oil level more frequently for long journeys:

- Towing a caravan or trailer
- In mountainous regions
- At high speeds
- In temperatures colder than -30°C or hotter than $+40^{\circ}\text{C}$.

Also check the oil level more often if the car is often driven short distances (less than 10 km) when temperatures are low (below $+5^{\circ}\text{C}$).

This can produce abnormally high oil temperature or oil consumption.



Before starting work on the car

Battery

Check that the battery cables are correctly connected and tightened.

Never disconnect the battery when the engine is running (e.g. if replacing the battery).

Never use a quick charger to charge the battery. The battery cables must be disconnected when charging the battery.

The battery contains acid that is both corrosive and toxic. Handle the battery in an environmentally-suitable way. Let your Volvo dealer assist you.



WARNING

High voltage output from the ignition system. The voltage in the ignition system is dangerous. The ignition must therefore always be switched off for work in the engine compartment.

Do not touch the spark plugs or ignition coils when the ignition is on or the engine is hot.

Check regularly

Check the following at regular intervals, for example, when refuelling:

- Coolant – The level must be between the **MIN** and **MAX** marks on the expansion tank.
- Engine oil – The level must be between the **MIN** and **MAX** marks.
- Power steering fluid – The level must be between the **MIN** and **MAX** marks.
- Washer fluid – The reservoir should be well filled. Use washer antifreeze at temperatures around freezing.
- Brake and clutch fluid – The level must be between the **MIN** and **MAX** marks.



WARNING

Bear in mind that the radiator fan may start automatically some time after the engine has been switched off.

Always have the engine cleaned by a workshop. There is a risk of fire if the engine is hot.



Bonnet and engine compartment

Opening the bonnet

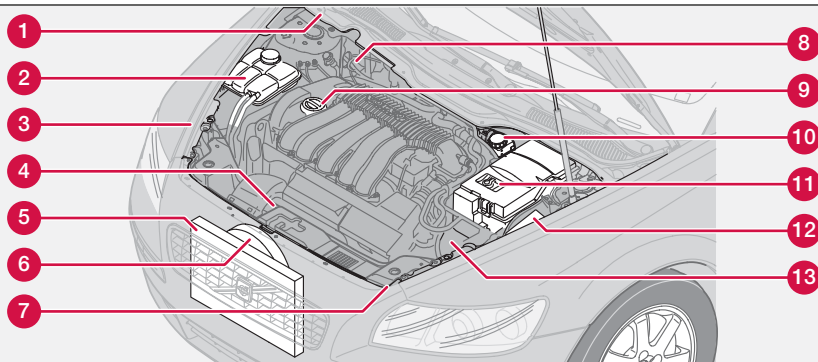
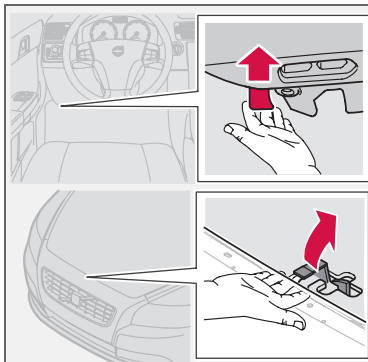

G020793

- Pull the handle on the far left under the dashboard. You will hear when the catch releases.
- Insert your hand under the centre of the front edge of the bonnet and press the safety catch to the right.
- Open the bonnet.



WARNING

Check that the bonnet locks properly when closed.

Engine compartment

- | | |
|---|--|
| 1. Washer fluid reservoir (4-cyl.) | 8. Brake and clutch fluid reservoir (right-hand drive) |
| 2. Coolant expansion tank | 9. Filler opening for engine oil ¹ |
| 3. Reservoir for the power steering fluid (concealed behind the headlamp) | 10. Brake and clutch fluid reservoir (left-hand drive) |
| 4. Engine oil dipstick ¹ | 11. Battery |
| 5. Radiator | 12. Relay and fuse box |
| 6. Radiator fan | 13. Air filter ¹ |
| 7. Washer fluid reservoir (5-cyl.) | |

¹ Dependent on engine variant



Fuel system

Diesel engines are sensitive to contaminants, such as high volumes of sulphur particles for example. Only use diesel fuel from a well-known producers. Never use diesel of dubious quality.

At low temperatures (–40 °C to –6 °C), a paraffin precipitate may form in the diesel fuel, which can lead to ignition problems. Special diesel fuel designed for low temperatures around freezing point is available from the major oil companies. This fuel is less viscous at low temperatures and reduces the risk of paraffin precipitate.

The risk of condensation in the fuel tank is reduced if the tank is kept well filled. When refuelling, check that the area around the fuel filler pipe is clean. Avoid spilling fuel onto the paintwork. Wash off any spillage with detergent and water.

IMPORTANT

Only ever use fuel that fulfils the European diesel standard, see page 247.

IMPORTANT

Diesel type fuels which must not be used: special additives, Marine Diesel Fuel, fuel oil, RME¹ (Rape Methyl Ester) and vegetable oil. These fuels do not fulfil the requirements in accordance with Volvo recommendations and generate increased wear and engine damage not covered by the Volvo warranty.

¹Diesel fuel may contain a certain amount of RME, but further amounts must not be added.

IMPORTANT

For model year 2006 or later the sulphur content must be a maximum of 50 ppm.

Empty tank

No special procedures are required if the tank runs dry. The fuel system is bled automatically if the ignition switch is kept in position **II** for approx. 60 seconds before the start attempt.

Draining condensation from the fuel filter

The fuel filter separates condensation from the fuel. Condensation can disrupt engine operation.

The fuel filter must be drained at the intervals specified in the Service and Warranty Booklet or if you suspect that the car has been refuelled with contaminated fuel.

IMPORTANT

Certain special additives remove the water separation in the fuel filter.



Oils and fluids

Engine compartment decal for oil grade

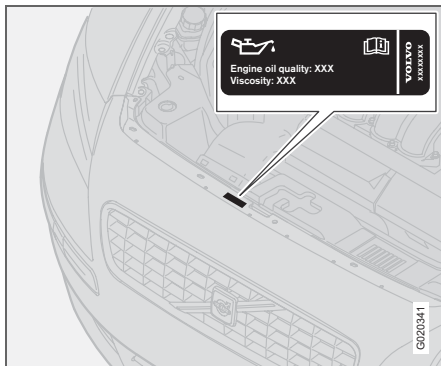

! IMPORTANT

Always use oil of the prescribed grade, see the engine compartment decal. Check the oil level frequently and change the oil regularly. The engine will be damaged if lower grade oil is used or if the car is driven with the oil level too low.

Using oil of a higher than specified grade is permitted. If the car is driven in adverse conditions, Volvo recommends using an oil of a higher grade than that specified on the decal. See page 239.

Checking the engine oil and oil filter

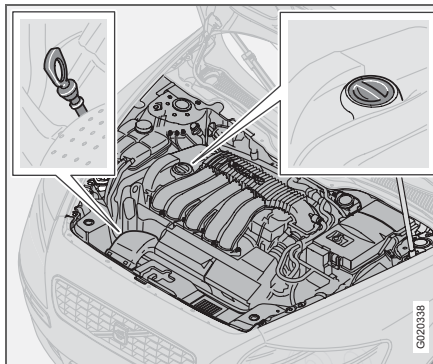

Dipstick, petrol engines

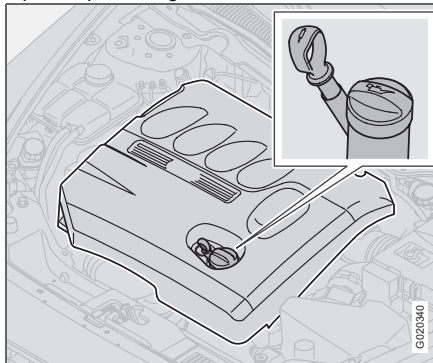

Dipstick, diesel engines

Volvo recommends Castrol oil products. Change the oil and replace the oil filter in accordance with the intervals specified in the Service and Warranty Booklet.

! IMPORTANT

In order to fulfil the requirements for the engine's service intervals all engines are filled with a specially adapted synthetic engine oil at the factory. The choice of oil has been made very carefully with regard to service life, starting characteristics, fuel consumption and environmental impact.

An approved engine oil must be used in order that the recommended service intervals can be applied. Only use a prescribed grade of oil (see the engine compartment decal) for both filling and oil change, otherwise you will risk affecting service life, starting characteristics, fuel consumption and environmental impact.

Volvo Car Corporation disclaims all warranty liability if engine oil of the prescribed grade and viscosity is not used.

Volvo uses different systems for warning of low oil level or low oil pressure. Certain variants have an oil pressure sensor, and then the lamp for oil pressure is used. Other variants have an oil level sensor, and then the driver is informed via the warning symbol in the centre of the instrument unit as well as by



display texts. Certain models have both variants. Contact an authorised Volvo dealer for more information.

Checking the oil level in a new car is especially important before the first scheduled oil change. The Service and Warranty Booklet specifies the odometer readings for oil changes.

Volvo recommends checking the oil level every 2 500 km. The most accurate measurements are made on a cold engine before starting. The measurement will be inaccurate if taken immediately after the engine is switched off. The dipstick will indicate that the level is too low because the oil has not had time to flow down into the oil sump.

Checking the oil

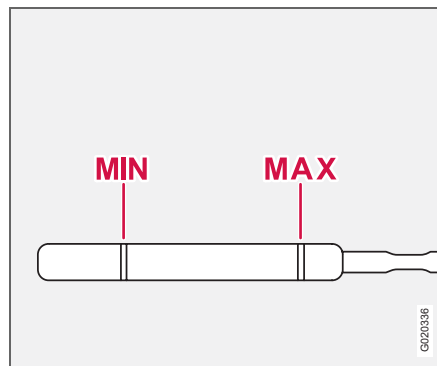

The oil level must be within the area marked on the dipstick.

Checking the oil in a cold engine:

- Wipe the dipstick clean before checking the level.
- Check the oil level using the dipstick. The oil level must be between the **MIN** and **MAX** marks.
- If the level is close to the **MIN** mark, start by topping up with 0.5 litres of oil. Top up until the oil level is nearer the **MAX** than the **MIN** mark on the dipstick. See page 239–240 for capacities.

Checking the oil in a warm engine:

- Park the car on a level surface, switch off the engine and wait 10–15 minutes to allow the oil time to run back to the sump.
- Wipe the dipstick clean before checking the level.
- Check the oil level using the dipstick. The oil level must be between the **MIN** and **MAX** marks.

If the level is close to the **MIN** mark, start by topping up with 0.5 litres of oil. Top up until the oil level is nearer the **MAX** than the **MIN** mark on the dipstick. See page 239–240 for capacities.



WARNING

Do not spill oil onto the hot exhaust manifold due to the risk of fire.



IMPORTANT

Never fill above the **MAX** mark. Oil consumption may increase if too much oil is poured into the engine.



Oils and fluids

Washer fluid, topping up

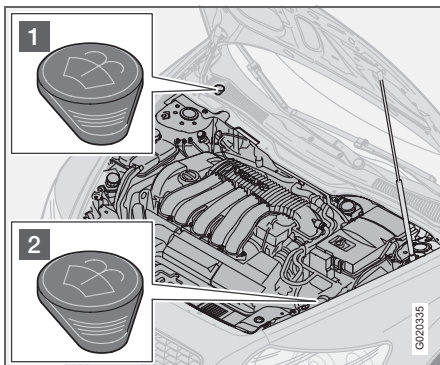

Location of washer fluid reservoir¹

The windscreen and headlamp washers share a common reservoir.

See capacities on page 244.

1. Filler cap on 4-cylinder engines and diesel.
2. Filler cap on 5-cylinder engines.

Add washer antifreeze during the winter so that the fluid does not freeze in the pump, reservoir and hoses.

i NOTE

Mix the washer antifreeze and water before filling the reservoir.

TIP! Clean the wiper blades when topping up washer fluid.

Checking and topping up the coolant

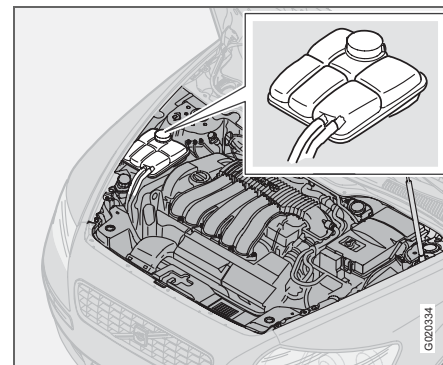

When topping up the coolant, follow the instructions on the packaging. It is important that the mixture of coolant concentrate and water is correct for the prevailing weather conditions. Never top up with water only. The risk of freezing increases with both too little and too much coolant concentrate.

i IMPORTANT

Always use coolant with anti-corrosion agent as recommended by Volvo. New cars are filled with coolant that can withstand temperatures down to approximately -35 °C.

See capacities on page 244.

¹ Dependent on engine variant



Check the coolant regularly

The level should lie between the **MIN** and **MAX** marks on the expansion tank. If the system is not filled sufficiently, high local temperatures could occur, causing a risk of damage (cracks) in the cylinder head. Top up the coolant when the level falls to the **MIN** mark.



WARNING

The coolant may be very hot. If the coolant requires topping up when the engine is at operating temperature, unscrew the expansion tank cap slowly to gently release the overpressure.



NOTE

The engine must only be run with a well-filled cooling system. High temperatures can occur, causing a risk of damage (cracks) to the cylinder head.

Checking and topping up the brake and clutch fluid

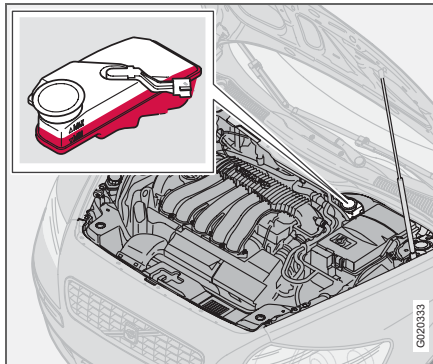

The brake and clutch fluid have a common reservoir¹. The fluid level must be between the **MIN** and **MAX** marks. Check the level regularly. Change the brake fluid every other year or at every other regular service.

See the capacities and recommended fluid grade on page 240.

The fluid should be changed annually on cars driven in conditions requiring hard, frequent braking, such as driving in mountains or tropical climates with high humidity.

¹ Location dependent on whether car is left or right-hand drive.



WARNING

If the brake fluid is under the **MIN** level in the brake fluid reservoir, do not drive further before topping up the brake fluid.

The reason for the loss of brake fluid must be investigated.



Oils and fluids

Checking and topping up the power steering fluid



NOTE

Check the level frequently.

The fluid does not require changing. For capacities and recommended fluid grade, see page 240.

If a fault should arise in the power steering system or if the car is without power and must be towed, it can still be steered. However the steering will be much heavier than normal and it will require more effort to turn the wheel.



Wiper blades

Changing the wiper blades

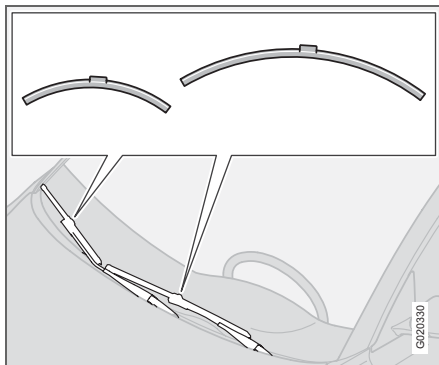

i NOTE

The wiper blades are different lengths. The blade on the driver's side is longer than the blade on the passenger side.

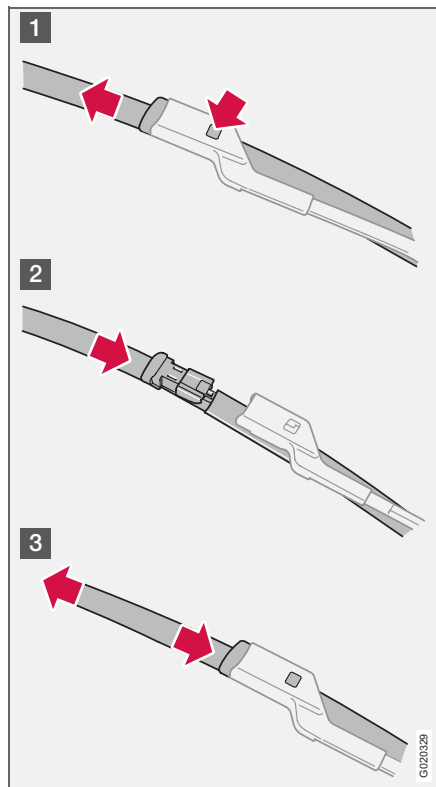
- Turn up the wiper arm.
- Press the button located on the wiper blade mounting and pull straight out (1), parallel with the wiper arm.
- Slide in (2) the new wiper blade until a "click" is heard.
- Check (3) that the blade is firmly installed.
- Fold down the wiper arm.

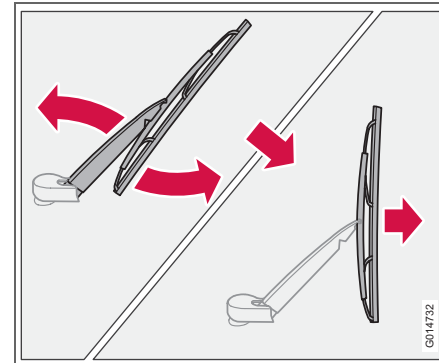

Changing the rear window wiper blade



- Fold out the wiper arm.
- Detach the wiper blade by pulling it towards the rear window.
- Press home the new wiper blade. Check that it is securely fitted.
- Lower the wiper arm.



Battery

Battery care

The service life and function of the battery is influenced by factors such as the number of starts, discharging, driving style, driving conditions and climatic conditions.

NOTE

An expended battery must be recycled in an environmentally responsible manner as it contains lead.

WARNING

Batteries can generate oxyhydrogen gas, which is highly explosive. A spark, which can be generated if you connect the jump leads incorrectly, is sufficient to make the battery explode. The battery also contains sulphuric acid, which can cause serious burns. If the acid comes into contact with eyes, skin or clothing, flush with large quantities of water. If acid splashes into the eyes, seek medical advice immediately.

NOTE

The life of the battery is shortened if it becomes discharged repeatedly.

Symbols on the battery

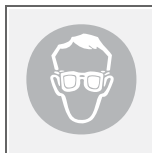

Use protective goggles.



Further information in the Owner's Manual.



Store the battery out of the reach of children.



The battery contains corrosive acid.



Avoid sparks and naked flames.



Risk of explosion.



Changing the battery

Removing the battery

- Switch off the ignition and remove the key.
- Wait at least 5 minutes before touching any electrical terminals. The car's electrical system has to store information in the control modules.
- Remove the cover.
- Disconnect the negative battery lead.
- Disconnect the positive battery lead.
- Undo the front wall of the battery box using a screwdriver.
- Release the clamp securing the battery.
- Remove the battery.

Fitting the battery

- Fit the battery into position.
- Fit the clamp securing the battery.
- Reinstall the front wall of the battery box.
- Connect the positive lead.
- Connect the negative lead.
- Refit the cover over the battery.



Replacing bulbs

General

All bulb specifications are given on page 251.

The following list contains bulbs and point-source lamps that are specialised or unsuitable for changing except at a workshop:

- General interior lighting in the roof
- Reading lamps and glovebox lighting
- Direction indicators, door mirror and approach lighting
- Brake light
- Bi-Xenon headlamp



WARNING

On cars with Bi-Xenon headlamps, Xenon lamp replacement must be carried out by an authorised Volvo workshop. The headlamps must be handled with extreme care due to the high-voltage unit in the Xenon lamp.



IMPORTANT

Never touch the bulbs' glass with your fingers. Grease and oils from your fingers are vaporised by the heat, coating and damaging the reflector.

Changing front bulbs

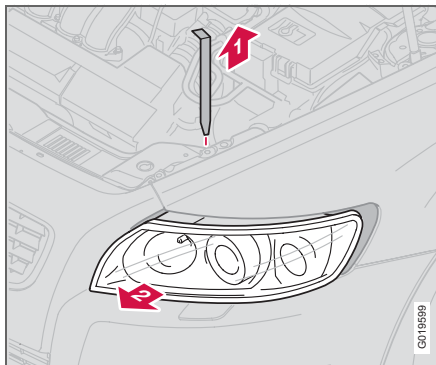

All front bulbs (except for fog lamps) are changed by first removing the lamp housing from the engine compartment.

Removing the lamp housing:

- Remove the ignition key and turn the light switch to position 0.
- Withdraw the lamp housing's locking pin (1).
- Pull the lamp housing to the side and then forward (2).



IMPORTANT

Do not pull the electrical cable, only the connector.

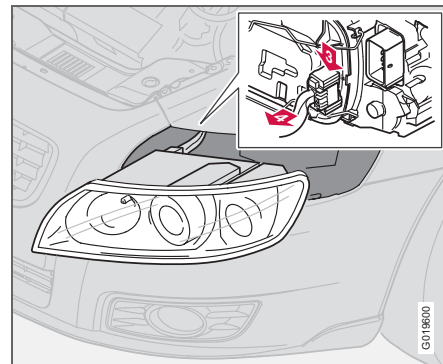

- Unplug the connector by pressing down the clip with a thumb (3) while moving out the connector (4) with the other hand.
- Lift out the lamp housing and place it on a soft surface to avoid scratching the lens.

Fitting the lamp housing:

- Plug in the connector and refit the lamp housing and locking pin. Check that the pin is correctly inserted.
- Check the lighting.

The lamp housing must be plugged in and secured in place before the lighting is turned on or the ignition key inserted into the ignition switch.



Replacing bulbs

09

Dipped beam

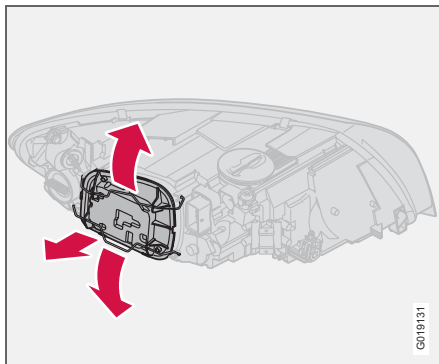

Removing the cover and bulb

- Undo the whole lamp housing, see page 194.
- Bend aside the catches and remove the cover.
- Unplug the connector from the bulb.
- Release the spring clip that secures the bulb. Press it in/down.
- Pull out the bulb.

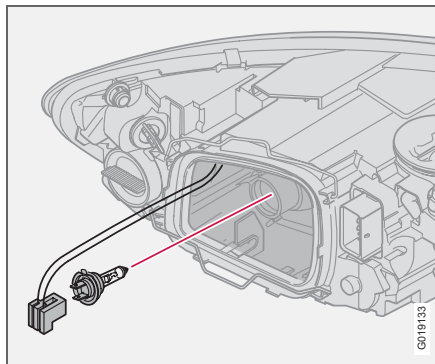

Fitting a new bulb

- Fit the new bulb. It can only be fitted in one position.
- Press the spring clip in/up and then slightly to the right in order to snap it into position.
- Press the connector back on.
- Refit the plastic cover.
- Refit the lamp housing, see page 194.

Main beam, halogen

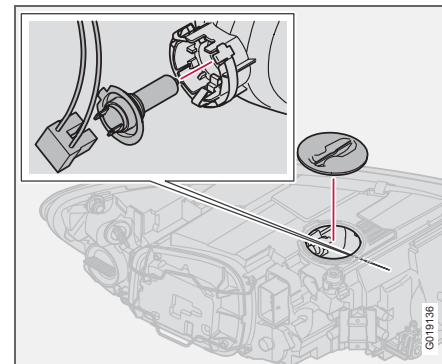

The illustration shows a halogen bulb

- Undo the whole lamp housing, see page 194.
- Undo the cover, located above the lamp housing, by turning it anticlockwise.
- Left-hand headlamp:
Turn the bulb holder anticlockwise.
- Right-hand headlamp:
Turn the bulb holder clockwise.



NOTE

If the car has ABL or GDL bulbs then the main beam bulb has another socket. In which case, pull the bulb straight out.



Replacing bulbs

- Withdraw the bulb holder and change the bulb.
- Refit the bulb holder. It can only be fitted in one way.
- Refit the cover, located above the lamp housing, by turning it clockwise.
- Refit the lamp housing, see page 194.

Position/parking lamps

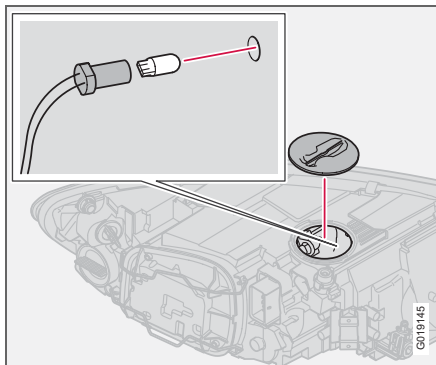

- Undo the lamp housing, see page 194.
- Undo the cover, located above the lamp housing, by turning it anticlockwise.
- Withdraw the bulb holder and change the bulb.
- Press back the bulb holder. A "click" is heard when the bulb holder is fitted correctly.
- Refit the cover, located above the lamp housing, by turning it clockwise.
- Refit the lamp housing, see page 194.



NOTE

A lamp equipped with the Active Bi Xenon Light (option) has a position lamp (LED) that cannot be replaced.

Direction indicators

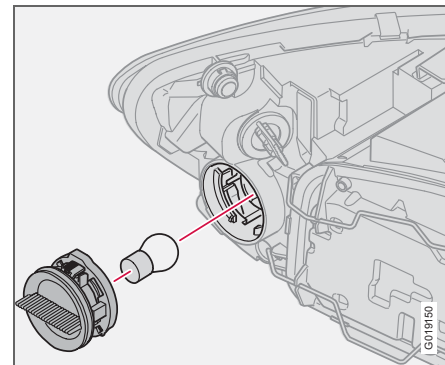

- Undo the lamp housing, see page 194.
- Twist the bulb holder anticlockwise and remove it.
- To remove the bulb from the bulb holder, press the bulb in and turn it anticlockwise.
- Fit a new bulb and refit the bulb holder into the lamp housing.
- Refit the lamp housing, see page 194.



Replacing bulbs

Side marker lamps

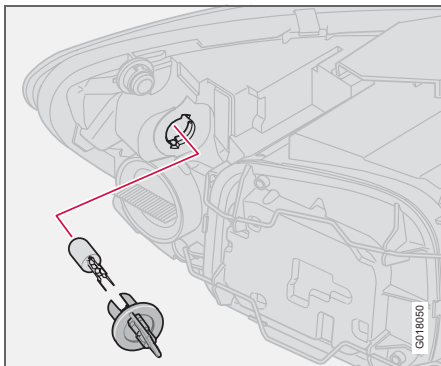

- Undo the lamp housing, see page 194.
- Twist the bulb holder anticlockwise and withdraw it. Replace the bulb.
- Refit the bulb holder. It can only be fitted in one way.
- Refit the lamp housing, see page 194.

Fog lamps

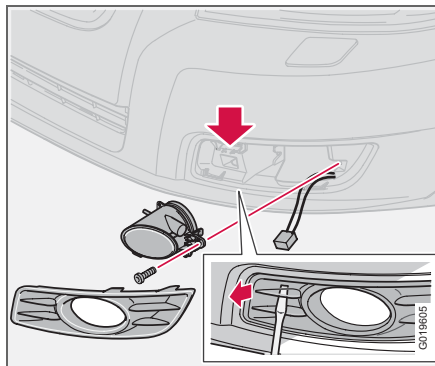

- Switch off all lights and turn the ignition key to position **0**.
- Undo the cover by inserting a screwdriver as illustrated (vertically) and continue to press vertically in order to undo the clip inside the cover.
- Grip the edge of the cover and pull straight out.
- Unscrew the lamp housing screw and remove it.
- Turn the bulb anticlockwise and remove it.
- Fit a new bulb by turning clockwise. (The profile of the bulb holder corresponds to the profile of the foot of the bulb.)

- Refit the bulb holder. The **TOP** mark on the bulb holder must always be upward.



Replacing bulbs

Removing the bulb holder

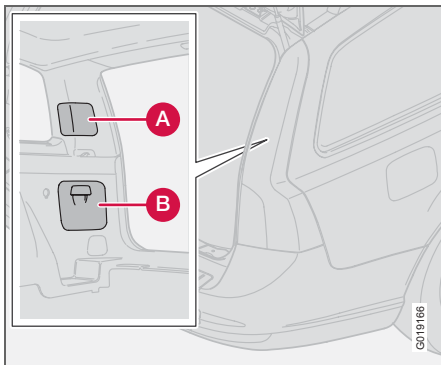

- Press the bulb holder into place and refit the cover (A or B).

NOTE

If the error message **BULB FAILURE/ CHECK STOP LAMP** remains after a faulty bulb has been replaced then consult an authorised Volvo workshop.

- All bulbs in the rear lamp cluster can be changed from inside the cargo area.
- Switch off all lights and turn the ignition key to position **0**.
- Remove the cover (A or B) in the left/right-hand panel to access the bulbs.
- These bulbs are located in separate bulb holders.
- Unplug the connector from the bulb holder.
- Squeeze together the catches and remove the bulb holder.
- Replace the bulb.
- Plug in the connector.



Replacing bulbs

Location of the bulbs in the rear light cluster

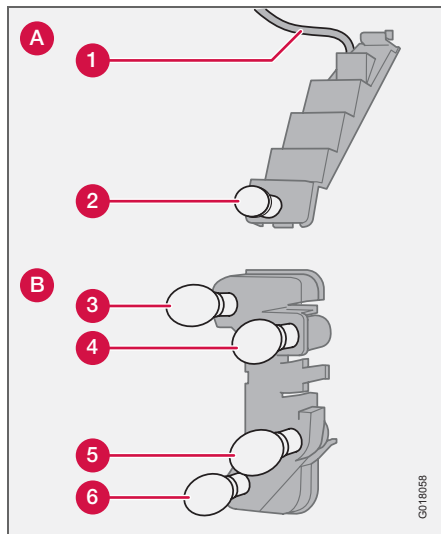

Bulb holder

! IMPORTANT

The cable for the brake light's LED lamps is moulded into the upper bulb holder. It shall not be removed.

1. Brake light (LED)
2. Position lamps

3. Position/parking lamps
4. Direction indicators
5. Reversing lamp
6. Rear fog lamp (one side)

Number plate lighting

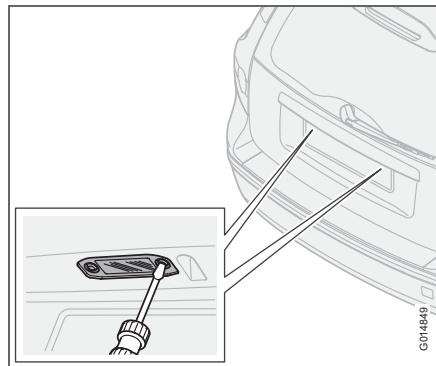

- Switch off all lights and turn the ignition key to position **0**.
- Remove the screws with a screwdriver.
- Detach the lens carefully.
- Replace the bulb.
- Refit and screw in the lens.

Courtesy lighting

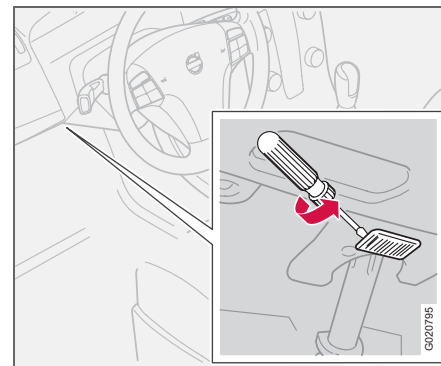

- There is courtesy lighting under the dashboard on the driver and passenger sides.
- Insert a screwdriver and gently turn so that the lens detaches.
- Remove the blown bulb.
- Fit a new bulb.
- Refit the lens.



Replacing bulbs

Cargo area

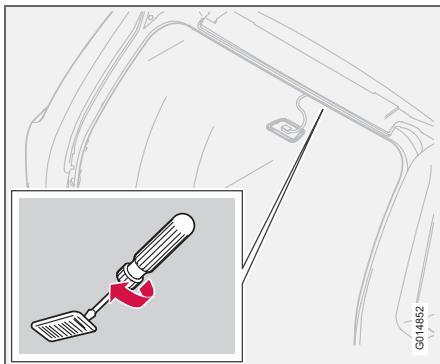

- Insert a screwdriver and gently turn so that the lamp housing comes loose.
- Remove the blown bulb.
- Fit a new bulb.

Vanity mirror lighting

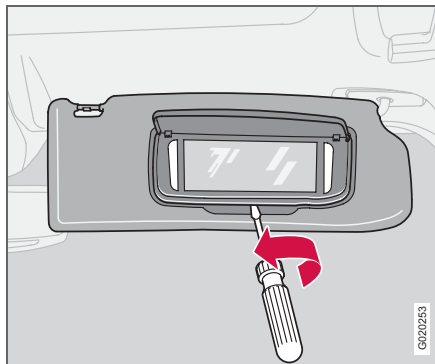

Removing the mirror glass:

- Insert a screwdriver underneath the lower edge, in the centre. Carefully prise up the lug on the edge.
- Insert the screwdriver under the edge on both the left and right side (at the black rubber points) and carefully prise so that the lens releases at the lower edge.
- Carefully detach and lift aside the entire mirror glass and cover.
- Remove the blown bulb and replace it with a new one.

Fitting the mirror glass:

- First, press the three lugs at top edge of mirror glass back into position.
- Then press the three lower lugs back into position.



General

All electrical functions and components are fused to protect the car's electrical system from damage by short circuiting and overloading.

The fuses are in two different locations in the car:

- Relay/Fuse box in the engine compartment
- Relay/fuse box in the passenger compartment.

Changing

If an electrical component or function does not work, it may be because the component's fuse was temporarily overloaded and blew.

- Look in the fuse diagram to locate the fuse.
- Pull out the fuse and check from the side to see whether the curved wire has blown.
- If this is the case, replace it with a new fuse of the same colour and amperage.

Each fuse box has space for several spare fuses. If the same fuse blows repeatedly it means that there is a fault in the component. Contact an authorised Volvo workshop to have the system checked.



Fuses

Relay/fuse box in the engine compartment

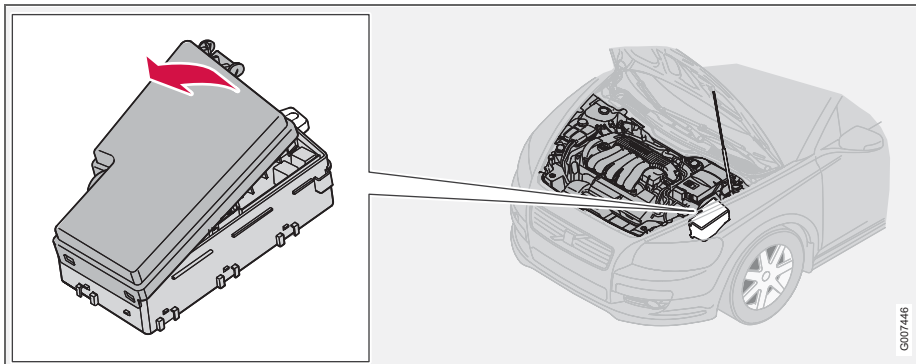

The fuse box has 36 fuse positions. Be sure to replace a blown fuse with a new fuse of the same colour and amperage.

- 19–36 are of the "Mini Fuse" type.
- Fuses 7–18 are of the "JCASE" type and should be replaced by an authorised Volvo workshop.
- Fuses 1–6 are of the "Midi Fuse" type and may only be replaced by an authorised Volvo workshop.

On the inside of the cover are tweezers to assist removing and fitting fuses.

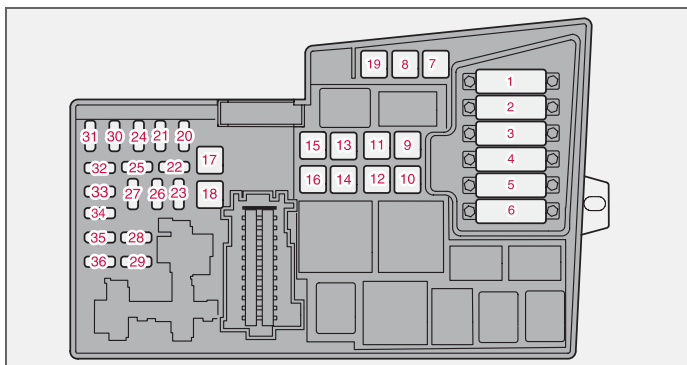

1. Radiator fan	50 A	13. Starter motor relay	30 A
2. Power steering (not 1.6 l engine)	80 A	14. Trailer wiring	40 A
3. Supply to passenger compartment fuse box	60 A	15. Reserve	-
4. Supply to passenger compartment fuse box	60 A	16. Supply to infotainment system	30 A
5. Climate control element, additional heater PTC (option)	80 A	17. Windscreen wipers	30 A
6. Glow plugs (4-cyl. diesel)	60 A	18. Supply to passenger compartment fuse box	40 A
Glow plugs (5-cyl. diesel)	70 A	19. Reserve	-
7. ABS pump	30 A	20. Horn	15 A
8. ABS valves	20 A	21. Fuel-driven additional heater, passenger compartment heater	20 A
9. Engine functions	30 A	22. Reserve	-
10. Ventilation fan	40 A	23. Engine control module ECM (5-cyl. petrol), transmission (TCM)	10 A
11. Headlamp washers	20 A	24. Heated fuel filter, PTC element oil trap (5-cyl. diesel)	20 A
12. Supply to heated rear window	30 A		

Fuses

25. Reserve	-
26. Ignition switch	15 A
27. A/C compressor	10 A
28. Reserve	-
29. Fog lamp, front	15 A
30. Engine control module ECM (1.6 l petrol, 2.0 l diesel).....	3 A
31. Voltage regulator, alternator 4-cyl.....	10 A
32. Injectors (5-cyl. petrol), lambda-sond (4-cyl. petrol), charge air cooler (4-cyl. diesel), mass air flow sensor and turbo control (5-cyl. diesel)	10 A
33. Lambda-sond and vacuum pump (5-cyl. petrol), engine control module (5-cyl. diesel), diesel filter heater (4-cyl. diesel)	20 A
34. Ignition coils (petrol), injectors (1.6 l petrol), fuel pump (4-cyl. diesel), pressure switch, climate control (5-cyl.), glow plugs and EGR emission control (5-cyl. diesel).....	10 A
35. Engine sensors for valves, relay coil, air conditioning PTC element, oil trap (5-cyl. petrol), engine control module ECM (5-cyl. diesel), canister (petrol), injectors (1.8/2.0 l petrol), MAF mass air flow sensor (5-cyl. petrol, 4-cyl. diesel), turbo control (4-cyl. diesel), pressure switch power steering (1.6 l petrol), EGR emission control (4-cyl. diesel).....	15 A
36. Engine control module ECM (not 5-cyl. diesel), accelerator pedal position sensor, lambda-sond (5-cyl. diesel)	10 A



Relay/fuse box in the passenger compartment

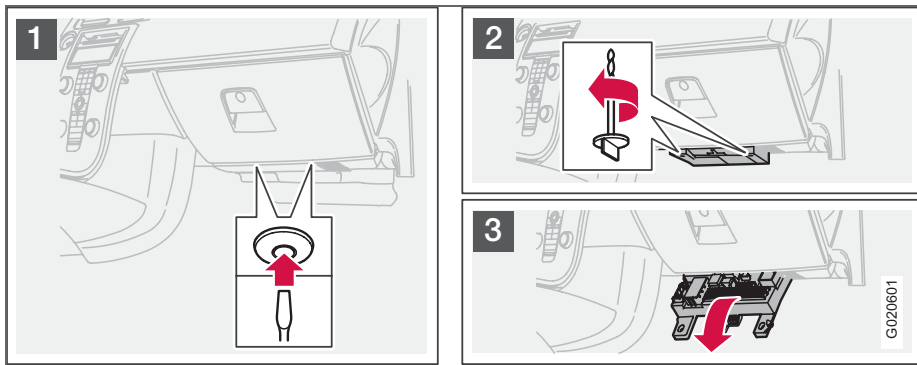

The fuse box has 50 fuse positions. The fuses are located under the glovebox. The box also provides space for several spare fuses. Tools for fuse replacement are located in the relay/fuse box in the engine compartment, see page 202.

Changing fuses:

- Remove the trim concealing the fuse box by pressing in the pin in the centre of the clips (1) about one cm and then withdrawing the clips.
- Turn the two wing screws (that secure the fuse box) (2) anticlockwise and remove them.
- Lower the fuse box (3) half way. Pull it towards the seat until it stops. Lower it completely. The fuse box can be fully unhooked.
- Close the fuse box in the reverse order.
- Remove the pins from the centre of the clips. Fit the trim and the clips, and reinsert the loose pins into the clips, this expands the clips and secures the trim.

Fuses

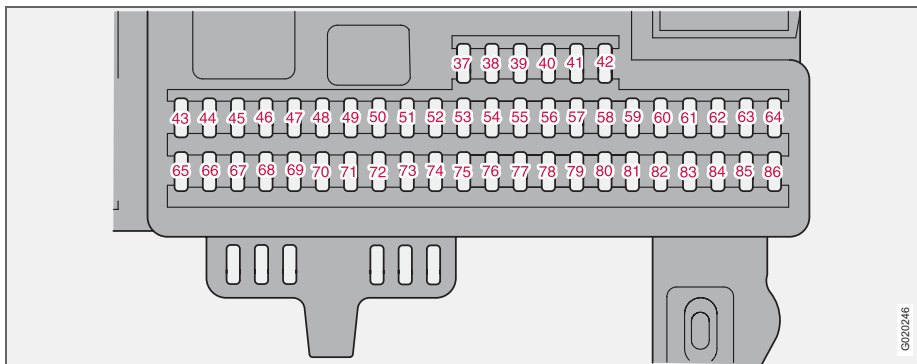

37. Reserve	49. SRS system	10 A
38. Reserve	50. Reserve	-
39. Reserve	51. Additional heater for the passenger compartment, AWD, fuel filter relay, heating	10 A
40. Reserve	52. Transmission control module (TCM), ABS system	5 A
41. Reserve	53. Power steering	10 A
42. Reserve	54. Parking assistance, Bi-Xenon (option)	10 A
43. Phone, audio system, RTI (option)	55. Keyless control module	20 A
44. SRS system, engine control module ECM (5-cyl.)	56. Remote control module, siren control module	10 A
45. Electrical socket	57. Data link connector (DLC), brake light switch	15 A
46. Passenger compartment, glovebox and courtesy lighting	58. Main beam (right), auxiliary lamps relay coil	7.5 A
47. Interior lighting	59. Main beam, left	7.5 A
48. Washer, rear window		

60. Seat heating (driver's side).....	15 A	84. Power passenger seat.....	25 A
61. Seat heating (passenger side).....	15 A	85. Power driver's seat	25 A
62. Sunroof	20 A	86. Interior lighting, cargo area lighting, power seats, fuel level display (1.8F).....	5 A
63. Supply to rear right door.....	20 A		
64. RTI (option).....	5 A		
65. Infotainment system	5 A		
66. Infotainment control module (ICM), climate control	10 A		
67. Reserve	-		
68. Cruise control.....	5 A		
69. Climate control, rain sensor, BLIS button.....	5 A		
70. Reserve	-		
71. Reserve	-		
72. Reserve	-		
73. Sunroof, overhead console for interior lighting (OHC), rear seatbelt reminder, autodim mirror	5 A		
74. Fuel pump relay	15 A		
75. Reserve	-		
76. Reserve	-		
77. Electrical socket in cargo area, accessory electronic module (AEM)	15 A		
78. Reserve	-		
79. Reversing lamp.....	5 A		
80. Reserve	-		
81. Supply to rear left door	20 A		
82. Supply to front right door.....	25 A		
83. Supply to front left door.....	25 A		

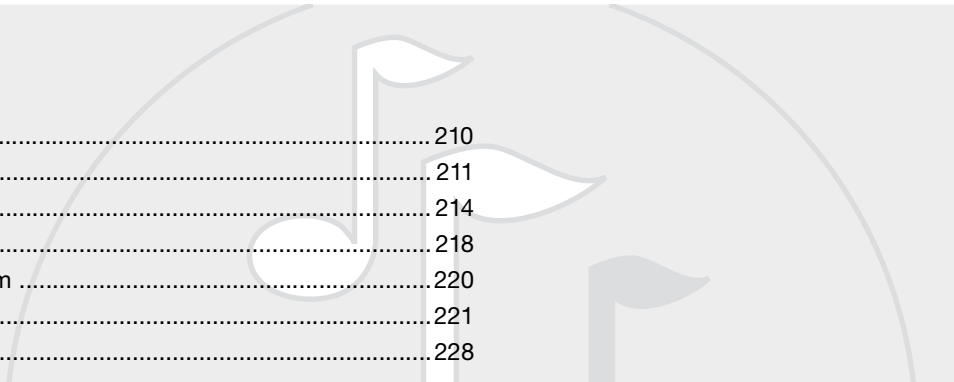

General	210
Audio functions	211
Radio functions	214
CD functions	218
Menu structure – audio system	220
Phone functions (option)	221
Menu structure – phone	228

INFOTAINMENT SYSTEM



10



10 Infotainment system

General

Infotainment system

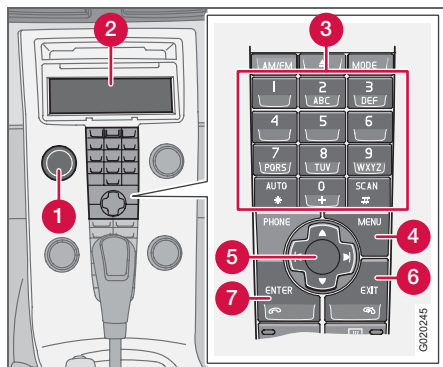

Infotainment is a system that integrates the audio system and the phone¹. The infotainment system can be easily operated using the control panel or the steering wheel keypad¹, see page 54. The display (2) shows messages and information on the current function.

Audio system

On/Off

POWER (1) switches the audio system on or off. If the audio system is active when the ignition key is turned to position **0** it continues to be active until the key is

¹ Option

removed from the ignition switch. The audio system is then started automatically the next time the key is turned to position **I**.

Menus

Some infotainment system functions are controlled via a menu system. The current menu level is shown at the top right of the display. Menu options are shown in the middle of the display.

- **MENU** (4) leads to the menu system.
- Up/down with the navigation button (5) moves between menu options.
- **ENTER** (7) selects or activates/deactivates a menu option.
- **EXIT** (6) goes back one step in the menu structure. A long press on **EXIT** will exit the menu system.

Shortcuts

Menu options are numbered and can also be selected directly with the keypad (3).

Equipment

The audio system can be equipped with different options and different versions. There are three audio system versions: Performance, High Performance and Premium Sound. FM and AM radio with RDS and CD player is however included in each version.

Dolby Surround Pro Logic II

Dolby Surround Pro Logic II² distributes the two stereo audio channels to left, centre, right and rear speakers. This provides a more realistic sound quality than that provided by standard two-channel stereo.



Dolby Surround Pro Logic II and the Dolby icon are trademarks of Dolby Laboratories Licensing Corporation.

The Dolby Surround Pro Logic II System is manufactured under license from Dolby Laboratories Licensing Corporation.

² Premium Sound



Audio functions

Audio controls

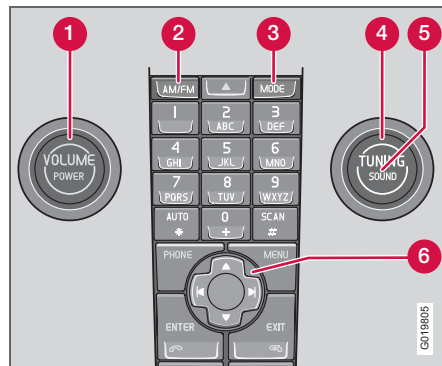

1. **VOLUME** – Knob
2. **AM/FM** – Audio source selection
3. **MODE** – Audio source selection, CD/AUX
4. **TUNING** – Knob
5. **SOUND** – Button

Volume

Use **VOLUME** (1) or the steering wheel key-pad to regulate the volume, see page 54. Audio volume adjusts automatically depending on vehicle speed, see page 213.

Audio source selection

Repeatedly pressing **AM/FM** switches between **FM1**, **FM2** and **AM**. Repeatedly pressing **MODE** switches between **CD** and **AUX**.

AUX

The AUX input can be used for connecting an MP3 player for example.

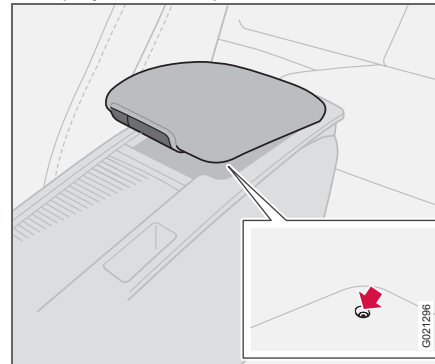

Input for external audio source (AUX) 3.5 mm



NOTE

The sound quality may be impaired if the player is charged while the audio system is in AUX mode, so avoid charging the player.

Sometimes the AUX external audio source can be heard at a different volume to the internal audio sources, e.g. the CD player. If the audio volume of the external audio source is too high then the sound quality could be impaired. Prevent this by adjusting the input volume of the AUX input.

- Set the audio system in AUX mode using **MODE**.
- Press **MENU** and then **ENTER**.
- Scroll to **AUX input Volume** and press **ENTER**.
- Turn **TUNING** or press right/left on the navigation button.



Audio functions

USB/iPod contact (option)

It is possible to connect an iPod and/or USB memory for example to the car's infotainment system via the contact in the centre console.

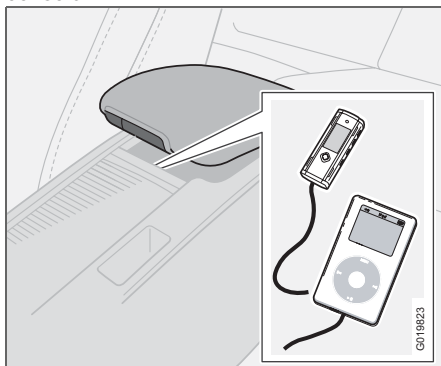

The audio source needs to be selected depending on what is connected:

- Select **iPod** or **USB** using **MODE**. The text **Connect Device** is shown on the display.
- Connect the storage media to the contact in the centre console's storage compartment (see illustration above).

The text **Loading** is shown in the display when the system indexes the files on the storage media. This takes a while.

When the indexing is finished the track information is shown on the display and it is possible to select the track required.

Track selection can take place in two ways:

- Turn **TUNING** (4) clockwise or anticlockwise
- or use the navigation control's (6) right or left-hand button to scroll to the required track.

If the car is equipped with a steering wheel keypad then it is also possible to change tracks using these controls.

NOTE

The system supports the playback of music files in the most common variants of the MP3, WMA and WAV file formats. There are also variants of these audio formats that are not supported by the system.

USB memory

To facilitate the use of USB memory, avoid storing any files other than music files in the memory. It takes considerably longer for the system to index storage media that contains items other than compatible music files.

MP3 player

Many MP3 players have their own file systems that are not supported by the audio system. To be able to use an MP3 player in

the system it must be set in the *USB Removable Device/Mass Storage Device* mode.

iPod player

The iPod player is charged and powered by the system via the connecting cable. However, if the iPod's battery is completely discharged then it must be charged before the iPod player is connected.

NOTE

When an iPod is used as an audio source, the car's infotainment system has a menu structure similar to the menu structure of the iPod player. See the iPod manual for detailed information.

For further information, see the accessory manual for *USB/iPod Music Interface*.

Audio settings

Adjusting audio settings

Repeatedly pressing **SOUND** browses between the following alternatives. Adjust by turning **TUNING**.

- **BASS** – Bass level.
- **TREBLE** – Treble level.
- **FADER** – Balance between the front and rear speakers.
- **BALANCE** – Balance between the left and right-hand speakers.



Audio functions

- **SUBWOOFER**¹ – Bass speaker level. The subwoofer must be activated before adjustment is possible. See page 213.
- **CENTRE**² – Centre speaker level. Three channel stereo or Pro Logic II must be activated before adjustment is possible. See page 213.
- **SURROUND**² – Surround sound level. Pro Logic II must be activated before adjustment is possible. See page 213.

Activating/deactivating the subwoofer

- Press **MENU** and then **ENTER**.
- Scroll to **Audio settings** and press **ENTER**.
- Scroll to **Subwoofer** and press **ENTER**.

Surround



Surround settings² govern the spatial perception of the sound. Settings and activating/deactivating are separate for each audio source.

The Dolby icon in the display indicates that Dolby Pro Logic II is active. There are three different settings for surround sound:

- **Pro Logic II**
- **3 channel**
- **Off** – 2-channel stereo.

¹ Option

² Premium Sound

Activating/deactivating surround sound

- Press **MENU** and then **ENTER**.
- Scroll to **Audio settings** and press **ENTER**.
- Scroll to **Surround FM/AM/CD/AUX** and press **ENTER**.
- Scroll to **Pro Logic II**³, **3 channel** or **Off** and press **ENTER**.

Equalizer front/rear

The equalizer⁴ can be used to adjust different frequency bands separately.

Adjusting equalizer

- Press **MENU** and then **ENTER**.
- Scroll to **Audio settings** and press **ENTER**.
- Scroll to **Equalizer front** or **Equalizer rear** and press **ENTER**.
- The graphic on the display indicates the audio level of the frequency in question.
- Adjust the level with **TUNING** (4) or up/down on the navigation button. Additional frequencies can be selected using the left/right navigation button.
- Use **ENTER** to save or **EXIT** to close.

³ Not available in AM and FM mode

⁴ Certain audio systems

Automatic volume control

The auto volume control function allows the audio volume to increase as the speed of the car increases. There are three levels to choose from⁵: **Low**, **Medium** and **High**.

Adjusting automatic volume control

- Press **MENU** and then **ENTER**.
- Scroll to **Audio settings** and press **ENTER**.
- Scroll to **Automatic volume control** and press **ENTER**.
- Scroll to **Low**, **Medium** or **High** and press **ENTER**.

Optimum sound reproduction

The audio system is calibrated for optimum sound reproduction by means of digital signal processing. This calibration takes into account loudspeakers, amplifiers, passenger compartment acoustics, listener position etc. for each combination of car model and audio system. There is also a dynamic calibration that takes into account the position of the volume control, radio reception and vehicle speed. The controls explained in these operating instructions, e.g. **Bass**, **Treble** and **Equalizer**, are only intended for the user to be able to adapt the sound reproduction according to personal taste.

⁵ Not Performance Sound



Radio functions

Radio controls

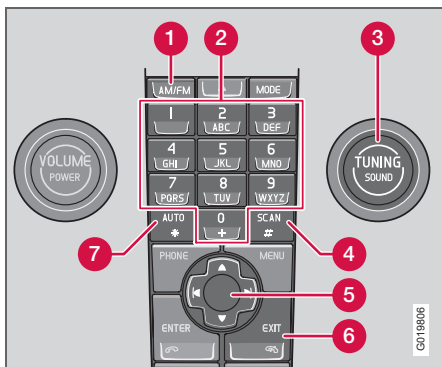

1. **FM/AM** – Wavelength selection
2. Station presets
3. **TUNING** – Knob for station searches
4. **SCAN** – Scanning
5. Navigation button – Tuning and menus
6. **EXIT** – Cancel current function
7. **AUTO** – Automatic storage of stations

Tuning

Automatic tuning

- Select wavelength using **AM/FM** (1).
- Give a brief press, left or right, on the navigation button (5).

Manual tuning

- Select wavelength using **AM/FM** (1).
- Adjust the frequency by turning **TUNING** (3).

Tune into a station with a long press (left or right) on the navigation button or by using the steering wheel keypad:

- Hold the right or left side of the navigation button depressed until the desired frequency appears in the display.

As long as the frequency graphic appears in the display, searching can be resumed by briefly pressing the navigation button (left or right) (5).

Storing stations

Ten station presets can be stored per wavelength. FM has two memories for presets: **FM1** and **FM2**. Preset stations are selected using the preset buttons (2) or the steering wheel keypad.

Storing stations manually

- Tune into a station.
- Hold a station preset button depressed until the message **Station stored** appears in the display.

Automatic storage of stations

AUTO (7) seeks out the ten strongest radio stations and stores them automatically in a separate memory. The function is especially useful in areas where one is unfamiliar with the radio stations and their frequencies.

Starting automatic storage of stations

- Select wavelength using **AM/FM** (1).
- Hold **AUTO** (7) depressed until **Autostoring...** appears in the display.

Once **Autostoring...** disappears from the display, the stations are stored. The radio continues in Auto mode and **Auto** appears in the display. The automatically stored stations can now be selected using the station preset buttons (2).

Cancelling automatic storage of stations

- Press **EXIT** (6).

Selecting an auto-stored preset

Allowing the radio to remain in Auto mode provides access to the autostored presets.

- Briefly press **AUTO** (7).

Auto appears in the display.

- Press a preset button (2).

The radio remains in Auto mode until it is exited by a brief press on **AUTO** (7), **EXIT** (6) or **AM/FM** (1).



Radio functions

Storing autostored presets in another memory

An autostored preset can be transferred to the FM or AM memory.

- Briefly press **AUTO** (7).

Auto appears in the display.

- Press a preset button.
- Press the button under which the station will be stored and hold it depressed until the message **Station stored** appears in the display.

The radio exits Auto mode and the stored station can be selected as a preset.

Scanning

SCAN (4) automatically searches for strong AM or FM stations. When a station is found, it is played for approx. eight seconds before scanning is resumed.

Activating/deactivating Scan

- Select wavelength using **AM/FM**.
- Press **SCAN** to activate.

SCAN appears in the display. Cancel with **SCAN** or **EXIT**.

Storing a station

A desired station can be stored as a preset while Scan is active.

- Press a preset button and hold it depressed until the message **Station stored** appears in the display.

Scan is interrupted and the stored station can be selected as a preset.

RDS functions

Radio Data System – RDS links FM transmitters into a network. An FM transmitter in such a network sends information that gives an RDS radio the following functions:

- Automatically switches to a stronger transmitter if reception in the area is poor.
- Searches for programme form, such as traffic information or news.
- Receives text information on current radio programme.

Some radio stations do not use RDS or only some if its functionality.

Programme functions

In FM mode, the radio can search for stations with certain programme types. If a desired programme type is found, the radio can switch stations, interrupting the audio source currently in use. For example, if the CD player is in use, it is paused. The interrupting transmission is played at a preset volume; see page 217. The radio returns to the previous audio source and volume when the set programme type is no longer broadcast.

The programme functions alarm (**ALARM**), traffic information (**TP**), news (**NEWS**), and programme types (**PTY**) interrupt one another in order of priority, where alarm has the highest priority and programme types has the lowest. For further programme interruption settings, see EON and REG on page 217. The programme functions are modified via the menu system, see page 210.

Returning to the interrupted audio source

Press **EXIT** to return to the interrupted audio source.

Alarm

This function is used to warn of serious accidents and catastrophes. The alarm cannot be temporarily interrupted or deactivated. The message **ALARM!** appears on the display when an alarm message is transmitted.

Traffic information – TP

TP

This function allows traffic information sent within a set station's RDS network to break through. **TP** indicates that the function is activated.

If the set station can send traffic information then **TP** appears on the display.



Radio functions

Activating/deactivating TP

- Press **MENU** and then **ENTER**.
- Scroll to **TP** and press **ENTER**.

TP from current station/all stations

The radio can interrupt with traffic information from only the set (current) station or from all stations.

- Select an FM station.
- Press **MENU** and then **ENTER**.
- Scroll to **Advanced radio settings** and press **ENTER**.
- Scroll to **TP** and press **ENTER**.
- Scroll to **TP Station** and press **ENTER**.

Either **TP from current station** or **TP from all stations** will appear in the display.

- Press **ENTER**.

Activating/deactivating TP search

TP search is useful during long journeys while an audio source other than the radio is being played. The function automatically searches for traffic information within different RDS networks.

- Press **MENU** and then **ENTER**.
- Scroll to **Advanced radio settings** and press **ENTER**.
- Scroll to **TP** and press **ENTER**.
- Scroll to **TP search** and press **ENTER**.

News

NEWS

This function allows news broadcasts within a set station's RDS network to break through. The message **NEWS** indicates that the function is active.

Activating/deactivating News

- Press **MENU** and then **ENTER**.
- Scroll to **News** and press **ENTER**.

News from current station/all stations

The radio can interrupt with news from only the set (current) station or from all stations.

- Select an FM station.
- Press **MENU** and then **ENTER**.
- Scroll to **Advanced radio settings** and press **ENTER**.
- Scroll to **News station** and press **ENTER**.

Either **News from current station** or **News from all stations** will appear in the display.

- Press **ENTER**.

Programme types – PTY

PTY

The PTY function can be used to select different programme types, such as **Pop music** and **Serious classic**. The PTY symbol indicates that the function is active. The function allows programme types transmit-

ted within a set station's RDS network to break through.

Activating/deactivating PTY

- Select **FM1** or **FM2** with **FM/AM**.
- Press **MENU** and then **ENTER**.
- Scroll to **PTY** and press **ENTER**.
- Scroll to **Select PTY** and press **ENTER**.

A list of programme types appears: **Current affairs**, **Information** etc. The PTY function is activated by selecting programme types and deactivated by clearing all PTYs.

- Select the desired programme types or **Clear all PTY**.

Search PTY

This function searches the entire wavelength for the selected programme type.

- Activate PTY.
- Press **MENU** and then **ENTER**.
- Scroll to **PTY** and press **ENTER**.
- Scroll to **Search PTY** and press **ENTER**.

If the radio finds any of the selected programme types, **>| To seek** appears in the display. Press the navigation button to the right to continue searching for another broadcast of the selected programme types.



Radio functions

Display of programme type

The programme type of the current station can be shown in the display.

i NOTE

Not all radio stations support this function.

Activating/deactivating display

- Press **MENU** and then **ENTER**.
- Scroll to **PTY** and press **ENTER**.
- Scroll to **Show PTY** and press **ENTER**.

Radio text

Some RDS stations transmit information on programme content, artists, etc. This information can be shown in the display.

Activating/deactivating radio text

- Press **MENU** and then **ENTER**.
- Scroll to **Radio text** and press **ENTER**.

Automatic frequency update – AF

The AF function selects one of the strongest transmitters for a set station. The radio may sometimes need to search through the entire FM wavelength to find a strong transmitter. If this occurs, the radio mutes and **PI seek Exit to cancel** appears on the display.

Activating/deactivating AF

- Press **MENU** and then **ENTER**.
- Scroll to **Advanced radio settings** and press **ENTER**.
- Scroll to **AF** and press **ENTER**.

Regional radio programmes – REG**REG**

This function causes the radio to continue with a regional transmitter even if its signal strength is low.

REG indicates that the function is active. The regional function is normally deactivated.

Activating/deactivating REG

- Press **MENU** and then **ENTER**.
- Scroll to **Advanced radio settings** and press **ENTER**.
- Scroll to **Regional** and press **ENTER**.

Enhanced Other Networks – EON

The EON function is particularly useful in urban areas with many regional radio stations. It allows the distance between the car and the radio station transmitter determine when programme functions should interrupt the current audio source.

- **Local** – interrupts only if the radio station transmitter is close.

- **Distant**¹ – interrupts if the station transmitter is far away, even if there is a lot of static.
- **Off** – no interruption for programmes from other transmitters.

Activating/deactivating EON

- Press **MENU** and then **ENTER**.
- Scroll to **Advanced radio settings** and press **ENTER**.
- Scroll to **EON** and press **ENTER**.
- Scroll to **Local**, **Distant** or **Off** and press **ENTER**.

Resetting RDS functions

Resets all radio settings to the original factory settings.

- Press **MENU** and then **ENTER**.
- Scroll to **Advanced radio settings** and press **ENTER**.
- Scroll to **Reset all** and press **ENTER**.

Volume control, programme types

The interrupting programme form is heard at the volume selected for such. If the volume level is adjusted during the programme interruption, the new level is saved until the next programme interruption.

¹ Default/Factory setting



CD functions

CD function controls

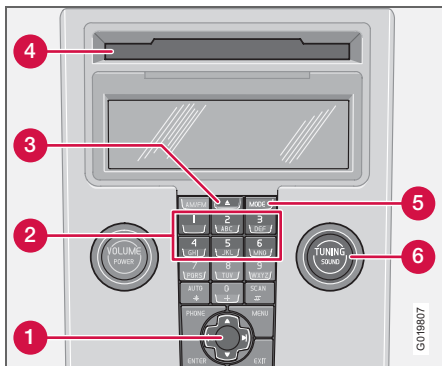

1. Navigation button – Fast forward/rewind, track selection and menus
2. CD changer position selection¹
3. CD insertion/eject
4. CD insertion/eject slot
5. **MODE** – Audio source selection CD and AUX¹
6. **TUNING** – Knob for track selection

Starting playback (CD player)

If a music CD is in the player when the audio system is in CD mode then playback is started automatically. Otherwise, load a disc and change to CD mode by pressing **MODE**.

¹ High Performance and Premium Sound

Starting playback (CD changer)

If a CD position with a music CD is already selected when the audio system is activated then playback starts automatically. Otherwise change to CD changer mode using **MODE** and select a disc with the number buttons **1–6** or Up/Down on the navigation button.

Inserting a CD (CD changer)

– Select an empty position with buttons **1–6** or Up/Down on the navigation button.
An empty position is marked on the display. The text **Insert disc** shows that a new disc can be inserted. The CD changer can hold up to six CDs.

- Insert a CD in the slot of the CD changer.

CD eject

A CD will stay in the ejected position for approx. 12 seconds. Following which it is re-inserted into the player and playback continues.

Eject individual discs by pressing the eject button (3).

Eject all discs with one long press on the eject button. The entire magazine is emptied disc by disc. The message **Eject all** is shown in the display.

Pause

If the volume is turned down completely, the CD player is stopped. The player is restarted when volume is increased.

Audio files¹

The CD player also supports MP3 and WMA format audio files.



NOTE

Certain types of copy-protected audio files cannot be read by the player.

When a CD containing audio files is inserted into the player the disc's directory structure is read in. It may take a while before playback starts depending on the quality of the disc.

Navigation and playback

If a disc containing audio files is inside the CD player then **ENTER** leads to the disc's directory structure. The directory structure is navigated in the same way as the audio system's menu structure. Audio files have the symbol and directories have the symbol . Start audio file playback with **ENTER**.

When the playback of a file is finished the playback of the other files in the same directory continues. Directory change takes place



CD functions

automatically when all files in the current directory have been played back.

Press left/right on the navigation button if the display is not wide enough to show the whole audio file name.

Fast-wind/change CD tracks and audio files

Short presses right/left on the navigation button are used to scroll between CD tracks/audio files. Long presses are used to fast-wind CD tracks/audio files. **TUNING** (or the steering wheel keypad) can also be used for this purpose.

Scan CD

This function plays the first ten seconds of each CD track/audio file. Press **SCAN** to activate. Interrupt with **EXIT** or **SCAN** to continue playback of the current CD track/audio file.

Random

This function plays the tracks in random order. The random CD tracks/audio files can be scrolled through in the normal way.



NOTE

It is only possible to scroll between random CD tracks on the current disc.

Different messages appear on the display depending on which random function has been selected.

- **RANDOM** means that the tracks from only one music CD are played.
- **RND ALL** means that all tracks on all music CDs in the CD changer are played.
- **RANDOM FOLDER** means that the audio files in a directory on the current CD are played.

Activating/deactivating (CD player)

- If a normal music CD is being played:
- Press **MENU** and then **ENTER**.
- Scroll to **Random** and press **ENTER**.

If a disc with audio files is being played:

- Press **MENU** and then **ENTER**.
- Scroll to **Random** and press **ENTER**.
- Scroll to **Folder** or **Disc** and press **ENTER**.

Activating/deactivating (CD changer)

If a normal music CD is being played:

- Press **MENU** and then **ENTER**.
- Scroll to **Random** and press **ENTER**.
- Scroll to **Single disc** or **All discs** and press **ENTER**.

The option **All discs** only applies to the music CDs in the changer.

If a CD with audio files is being played:

- Press **MENU** and then **ENTER**.
- Scroll to **Random** and press **ENTER**.
- Scroll to **Single disc** or **Folder** and press **ENTER**.

The function is deactivated when another CD is selected.

Disc text

If title information is stored on a music CD it can be shown on the display¹.

Activating/deactivating

- Start CD playback.
- Press **MENU** and then **ENTER**.
- Scroll to **Disc text** and press **ENTER**.

CDs

Using low quality CD discs could result in poor or non-existent sound.



IMPORTANT

Only use standard discs (12 cm in diameter). Do not use CDs with adhesive disc labels. The heat in the CD player may cause the label to come off, damaging the CD player.

¹ Only applies to CD changer



Menu structure – audio system

FM menu

1. News
2. TP
3. PTY
4. Radio text
5. Advanced radio settings
6. Audio settings¹

AM menu

1. Audio settings¹

CD menu

1. Random
2. News
3. TP
4. Disc text
5. Audio settings¹

CD changer menu

1. Random
2. News
3. TP
4. Disc text
5. Audio settings¹

AUX menu

1. AUX volume
2. News
3. TP
4. Audio settings¹

¹ Certain audio systems



Phone functions (option)

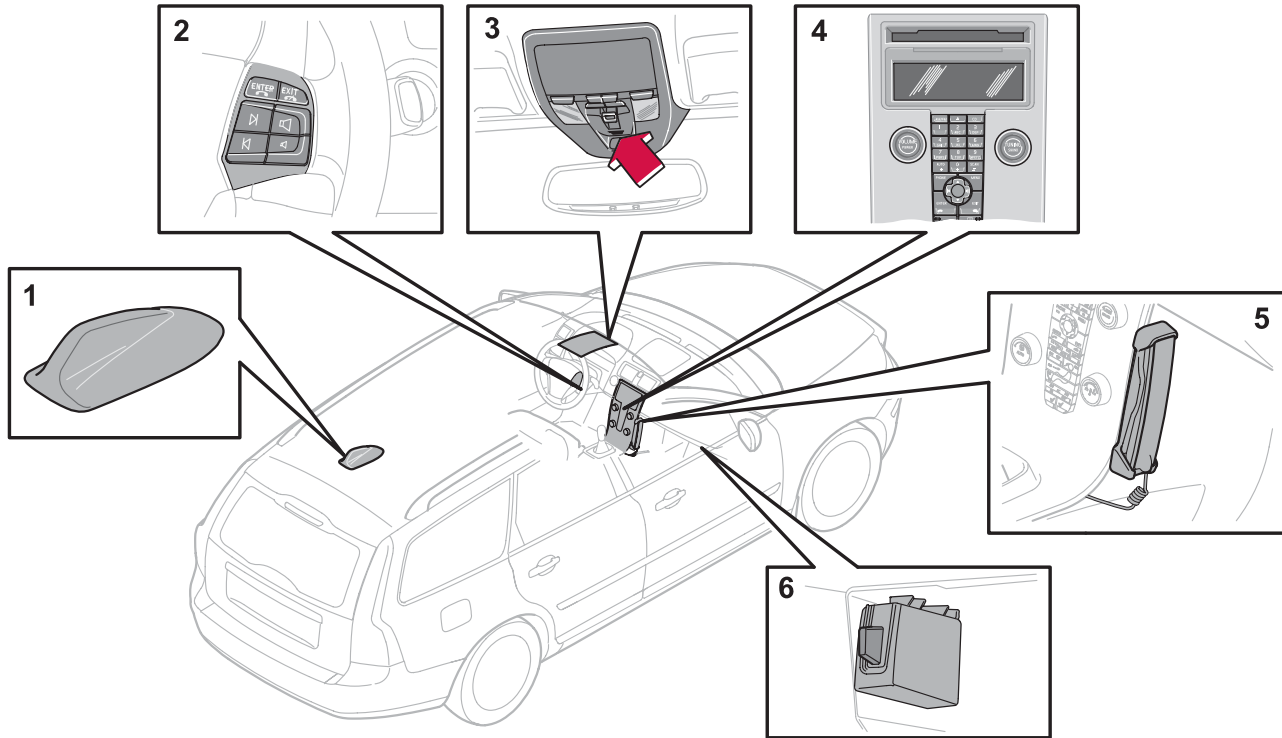

Phone system components



Phone functions (option)

Phone system components

1. Antenna

2. Steering wheel keypad (option)

Most phone system functions can be accessed via the keypad. See page 223.

3. Microphone

The hands free microphone is integrated in the roof console beside the rearview mirror.

4. Centre console control panel

All phone functions (except call volume) can be regulated via the control panel.

5. Privacy handset (option)

6. SIM card reader

General

- Always put traffic safety first.
- If the driver needs to use the privacy handset, park the car in a safe place first.
- Switch off the phone system when refuelling the car.
- Switch off the system near blasting work.
- Only entrust phone system servicing to an authorised Volvo workshop.

Emergency calls

Emergency calls to alarm centres can be made without a SIM card as long as there is coverage by a GSM operator.

Making an emergency call

- Activate the phone.
- Ring the emergency number that applies to your region (within EU: 112).
- Press **ENTER**.

IDIS

The IDIS system (Intelligent Driver Information System) allows incoming phone calls and SMS messages to be delayed so that the driver can concentrate on driving. Incoming calls and SMS messages can be delayed five seconds before they are connected. Missed calls are shown on the display. IDIS can be deactivated using menu function 5.6.2, see page 229.

SIM card

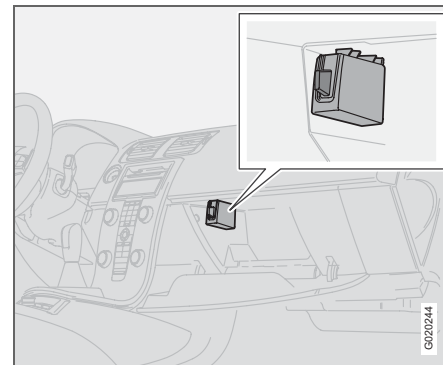

The phone can only be used with a valid SIM card (Subscriber Identity Module). The card is available from various network operators. Contact your network operator if you experience difficulties with the SIM card.



NOTE

The built-in phone cannot read 3G only SIM cards. Combined 3G/GSM cards do work. Contact your network operator if you need to change your SIM card.



Phone functions (option)

Double SIM cards

Many network operators offer two SIM cards for the same phone number. The extra SIM card can be used in the car.

Inserting the SIM card

- Switch off the phone and open the glove-box.
- Pull out the SIM card holder (1) in the SIM card reader.
- Position the SIM card in the holder with the metal surface visible. The bevelled edge of the SIM card should align with the bevel of the SIM card holder.
- Carefully press in the SIM card holder.

Menus

Page 210 describes how to control phone functions with the menu system.

Traffic safety

For safety reasons, parts of the phone menu system cannot be accessed at speeds in excess of 8 km/h. Only activities started in the menu system can be completed. The speed limiter can be deactivated using menu function 5.6.1 Menu lock, see page 228.

Phone controls

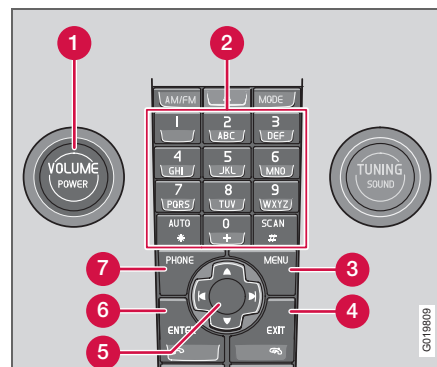

Centre console control panel

1. **VOLUME** – Control the background volume from the radio, for example, during a call.
2. Number and letter buttons
3. **MENU** – Opens the main menu
4. **EXIT** – End/refuse calls, clear entered characters
5. Navigation button – Scroll in menus and character rows
6. **ENTER** – Accept calls, activate the phone from standby mode
7. **PHONE** – On/off and standby mode

Steering wheel keypad

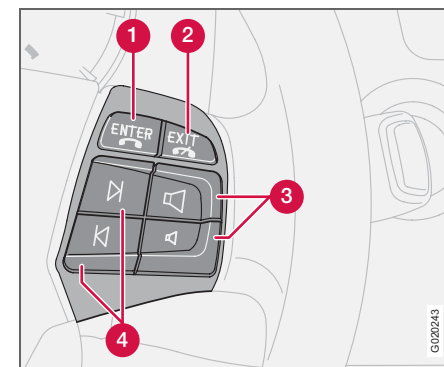

When the phone is active, the steering wheel keypad is locked to phone functions. To control the audio system, the phone must be in standby mode.

1. **ENTER** – Works the same as on the control panel
2. **EXIT** – Works the same as on the control panel
3. Call volume – Increase/decrease
4. Navigation buttons – Scroll in menus



Phone functions (option)

On/Off

A handset appears in the display when the phone system is active or in standby mode. If the ignition key is turned to position **0** when the phone is in one of these modes, the phone automatically resumes this mode the next time the key is turned to position **I** or **II**.

Activating the phone system

Phone system functions can only be used when the phone is in active mode.

- Press **PHONE**.
- Enter the PIN code (if necessary) and press **ENTER**.

Deactivating the phone system

No calls can be received when the phone is deactivated.

- Hold **PHONE** depressed until the phone is activated.

Standby

In standby mode, the audio system can be in use while calls are received. However, it is not possible to make calls when in standby mode.

Putting the phone in standby mode

The phone must first be in active mode before it can be put in standby mode.

- Press **PHONE** or **EXIT**.

Activating from standby mode

- Press **PHONE**.

Making and receiving calls

If the privacy handset is raised when a phone call is started, the sound will come from the handsfree system. For information on switching between privacy handset and handsfree during a call, see page 226.

To call

- Activate the phone system (if necessary).
- Dial the number or use the phone book, see page 226.
- Press **ENTER** or lift the handset. Release the handset by pressing it down.

Receiving a call

For Auto answer, see menu option 4.3, page 228.

- Press **ENTER** or lift the handset. Release the handset by pressing it down.

Ending a call

- Press **EXIT** or hang up the handset.

Refusing a call

- Press **EXIT**.

Call waiting

A two-tone signal during a phone call indicates that there is another incoming call. **Answer?** appears on the display. The call can be refused or taken in the normal manner. If the incoming call is taken, the previous call is put on hold.

Putting a call on hold/resuming a call

- Press **MENU**.
- Scroll to **Hold** or **Hold off** and press **ENTER**.

Dialling a third party

- Put the call on hold.
- Dial the number of the third party.

Switching between calls

- Press **MENU**.
- Scroll to **Swap** and press **ENTER**.

Starting a conference call

A conference call consists of at least three parties that can talk to one another. Once a conference call has been initiated, no more parties can be connected. All calls are ended when the conference call is ended.

- Start two phone calls
- Press **MENU**.
- Scroll to **Join** and press **ENTER**.



Phone functions (option)

Volume

The phone uses the driver's door or centre speaker¹.

Call volume



Call volume is regulated with the buttons of the steering wheel keypad.

If the privacy handset is used, volume is regulated with a wheel on the side of

the handset.

Audio system volume

Audio system volume is temporarily lowered during a phone call. Once the call is ended the previous volume is resumed. If the volume is regulated during the call, the new level is retained once the call is ended. Sound can also be automatically muted during a phone call; see menu 5.5.3, page 229. This function is only available with the Volvo integrated phone system.

Entering text

Text is entered using the phone keypad.

- Press the key with the desired character - once for the first character on the button, twice for the second, etc. See table.

- Press 1 for a space. If two characters in a row are to be entered using the same key, press * or wait a few seconds.

A brief press on **EXIT** will clear an entered character. A long press on **EXIT** will clear all entered characters.

1	space 1- ? ! , . : " ' ()
2	a b c 2 ä å à æ ç
3	d e f 3 è é
4	g h i 4 ì
5	j k l 5
6	m n o 6 ñ ö ò ø
7	p q r s 7 ß
8	t u v 8 ü ù
9	w x y z 9
*	Used if two characters are to be ended with the same button.
0	+ 0 @ * # & \$ £ / %
#	Switch between upper and lower case.

Handling numbers

Calling the last number dialed

The phone automatically stores the last phone numbers dialed.

- Press **ENTER**.
- Scroll to a number and press **ENTER**.

Phone book

If the phone book contains the desired party's contact information, these are shown in the display. Contact information can be stored on the SIM card and in the phone.

Storing contacts in the phone book

- Press **MENU**.
- Scroll to **Phone book** and press **ENTER**.
- Scroll to **New number** and press **ENTER**.
- Enter a name and press **ENTER**.
- Enter a number and press **ENTER**.
- Scroll to **SIM card** or **Phone** and press **ENTER**.

Searching for contacts in the phone book

Use the down arrow of the navigation button instead of **MENU** for direct access to the Search menu.

- Press **MENU**.
- Scroll to **Phone book** and press **ENTER**.

¹ Premium Sound



Phone functions (option)

- Scroll to **Search** and press **ENTER**.
- Enter the first few letters of the item and press **ENTER**, or simply press **ENTER**.
- Scroll to an item and press **ENTER**.

Copying entries between the SIM card and Phone book

- Press **MENU**.
- Scroll to **Phone book** and press **ENTER**.
- Scroll to **Copy all** and press **ENTER**.
- Scroll to **SIM to phone** or **Phone to SIM** and press **ENTER**.

Deleting contacts from the phone book

- Press **MENU**.
- Scroll to **Phone book** and press **ENTER**.
- Scroll to **Search** and press **ENTER**.
- Enter the first few letters of the item and press **ENTER**, or simply press **ENTER**.
- Scroll to the item to be erased and press **ENTER**.
- Scroll to **Erase** and press **ENTER**.

Erase all contacts

- Press **MENU**.
- Scroll to **Phone book** and press **ENTER**.
- Scroll to **Erase SIM** or **Erase phone** and press **ENTER**.

If required, enter phone code. The factory-set default code is 1234.

Speed dial

A keypad button (1-9) can be used as a speed dial number for a contact in the phone book.

- Press **MENU**.
- Scroll to **Phone book** and press **ENTER**.
- Scroll to **One-key dial** and press **ENTER**.
- Scroll to **Select numbers** and press **ENTER**.
- Scroll to the digit of the keypad button for the speed dial number and press **ENTER**.
- Enter the first few letters of the item and press **ENTER**, or simply press **ENTER**.
- Scroll to an item and press **ENTER**.
- Hold **EXIT** depressed to leave the menu system.

Calling using speed dial

- Hold the desired keypad button for approx. two seconds or briefly press the button and then **ENTER**.



NOTE

When the phone is switched on, it takes a while before speed dialling is available.

To use the speed dial function **One-key dial** must be activated in the **Phone book** menu, see page 230.

Calling from the phone book

- Press **MENU**.
- Scroll to **Phone book** and press **ENTER**. All contacts in the phone book memory are displayed. The number of contacts displayed can be reduced by entering part of the contact's name.
- Scroll to a contact and press **ENTER**.



NOTE

Press **ENTER** to dial.

Functions during a call

Several functions are available during a call. Some functions can only be used when a call is on hold.

Press **MENU** to access the In-call menu and scroll to one of the following alternatives:

- **Mute/Mute off** – Mute mode.
- **Hold/Hold off** – Put a call on hold or resume a call.
- **Handsfree/Handset** – Use handsfree or the privacy handset.
- **Phone book** – Access the phone book.
- **Join** – Conference calling (available if more than three parties are connected).



Phone functions (option)

- **Swap** – Switch between two calls (available if up to three parties are connected).

SMS – Short Message Service

Reading SMS

- Press **MENU**.
- Scroll to **Messages** and press **ENTER**.
- Scroll to **Read** and press **ENTER**.
- Scroll to a message and press **ENTER**.

The message text appears in the display. Additional selections can be made by pressing **ENTER**. Hold **EXIT** depressed to leave the menu system.

Writing and sending

- Press **MENU**.
- Scroll to **Messages** and press **ENTER**.
- Scroll to **Write new** and press **ENTER**.
- Enter text and press **ENTER**.
- Scroll to **Send** and press **ENTER**.
- Enter a phone number and press **ENTER**.

IMEI number

To block the phone, you must provide your network operator with the phone's IMEI number. This is a 15 digit serial number that is programmed into the phone. Dial *#06# to display this number. Make a note of this number and keep it in a safe place.

Specifications

Output	2 W
SIM card	Small
Memory entries	255 ¹
SMS (Short Message Service)	Yes
Data/Fax	No
Dualband (900/1800 MHz)	Yes

¹The capacity of the SIM card's memory varies depending on the subscription.



Menu structure – phone

Overview

1. Call register

- 1.1. Missed calls
- 1.2. Received calls
- 1.3. Dialed no.
- 1.4. Erase list
 - 1.4.1. All calls
 - 1.4.2. Missed calls
 - 1.4.3. Received calls
 - 1.4.4. Dialed no.
- 1.5. Call duration
 - 1.5.1. Last call
 - 1.5.2. Number of calls
 - 1.5.3. Total time
 - 1.5.4. Reset time

2. Messages

- 2.1. Read
- 2.2. Write
- 2.3. Message sett
 - 2.3.1. SMSC number
 - 2.3.2. Validity time
 - 2.3.3. Message type

3. Phone book

- 3.1. New number
- 3.2. Search
- 3.3. Copy all
 - 3.3.1. SIM to phone
 - 3.3.2. Phone to SIM
- 3.4. One-key dial
 - 3.4.1. Active
 - 3.4.2. Select number
- 3.5. Erase SIM
- 3.6. Erase phone
- 3.7. Memory status

4. Call options

- 4.1. Send my no.
- 4.2. Call waiting
- 4.3. Auto answer
- 4.4. Automatic redial
- 4.5. Diversion
 - 4.5.1. All calls
 - 4.5.2. When engag.
 - 4.5.3. Not answered
 - 4.5.4. Not reachable
 - 4.5.5. Fax calls
 - 4.5.6. Data calls
 - 4.5.7. Cancel all diverts

5. Tel. settings

- 5.1. Network
 - 5.1.1. Automatic
 - 5.1.2. Manual select
- 5.2. Language
 - 5.2.1. English UK
 - 5.2.2. English US
 - 5.2.3. Español
 - 5.2.4. Français CAN
 - 5.2.5. Français FR
 - 5.2.6. Italiano
 - 5.2.7. Nederlands
 - 5.2.8. Português BR
 - 5.2.9. Português P
 - 5.2.10. Suomi
 - 5.2.11. Svenska
 - 5.2.12. Dansk
 - 5.2.13. Deutsch
- 5.3. SIM security
 - 5.3.1. On
 - 5.3.2. Off
 - 5.3.3. Automatic
- 5.4. Edit codes
 - 5.4.1. PIN code
 - 5.4.2. Phone code
- 5.5. Sound
 - 5.5.1. Ring volume
 - 5.5.2. Ring signal



Menu structure – phone

- 5.5.3. Mute radio
- 5.5.4. Msg. beep
- 5.6. Traff. safety
 - 5.6.1. Menu lock
 - 5.6.2. IDIS
- 5.7. Factory sett.

Description of menu options

1. Call register

1.1. Missed calls

List of missed calls. You can choose to call, erase or store the number in the phone book.

1.2. Received calls

List of received calls. You can choose to call, erase or store the number in the phone book.

1.3. Dialed no.

List of previously dialed numbers. You can choose to call, erase or store the number in the phone book.

1.4. Erase list

Erase the lists found in the menus 1.1, 1.2 and 1.3 as below.

- 1.4.1. All
- 1.4.2. Missed
- 1.4.3. Received
- 1.4.4. Dialed no.

1.5. Call duration

Duration of all calls or of the most recent call. The phone code is required to reset the call timer (see menu 5.4).

- 1.5.1. Last call
- 1.5.2. Number of calls
- 1.5.3. Total time
- 1.5.4. Reset time

2. Messages

2.1. Read

Received text messages. Select whether to erase, forward, change or save the entire message or parts of it.

2.2. Write

Write a message using the keypad. Choose whether to save or send it.

2.3. Message sett

Enter the number (SMSC number) of the message centre to which messages are to be transferred as well as how long they are to be saved at the message centre. Contact your network operator for information on message settings. Normally, these settings should not be altered.

- 2.3.1. SMSC number
- 2.3.2. Validity time
- 2.3.3. Message type

3. Phone book

3.1. New number

Store names and phone numbers in the phone book, see page 225.

3.2. Search

Search for a name in the phone book.



Menu structure – phone

3.3. Copy all

Copy phone numbers and names from the SIM card to the phone memory.

- 3.3.1. From SIM to phone memory
- 3.3.2. From phone to SIM memory

3.4. One-key dial

A number stored in the phone book can be stored as a speed dial number.

3.5. Erase SIM

Erase the entire SIM card memory.

3.6. Erase phone

Erase the entire phone memory.

3.7. Memory status

Shows how many positions are occupied in the SIM card and phone memory. The table shows how many of the total number of positions are occupied, e.g. 100 (250).

4. Call options

4.1. Send my no.

Displays or hides your phone number to/from the person you call. Contact your network operator regarding ex-directory numbers.

4.2. Call waiting

Be alerted during a phone call that there is another incoming call.

4.3. Auto answer

Automatically answers incoming calls.

4.4. Call back

Calls a previously engaged number.

4.5. Diversion

Choose when and what type of calls are to be diverted to a specified phone number.

- 4.5.1. All calls (this setting only applies during the call in progress).
- 4.5.2. When engaged.
- 4.5.3. Not answered
- 4.5.4. Not reachable
- 4.5.5. Fax calls
- 4.5.6. Data calls
- 4.5.7. Cancel all diversions

5. Phone settings

5.1. Network

Choose a network automatically or manually. The selected operator is shown in the display in the phone's basic mode.

- 5.1.1. Auto
- 5.1.2. Manual select

5.2. Language

Select the phone language.

- 5.2.1. English UK
- 5.2.2. English US
- 5.2.3. Español
- 5.2.4. Français CAN
- 5.2.5. Français FR
- 5.2.6. Italiano
- 5.2.7. Nederlands
- 5.2.8. Português BR
- 5.2.9. Português P
- 5.2.10. Suomi
- 5.2.11. Svenska
- 5.2.12. Dansk
- 5.2.13. Deutsch

5.3. SIM security

Select if the PIN code should be on, off or if the phone should automatically give the PIN code.

- 5.3.1. On
- 5.3.2. Off
- 5.3.3. Automatic

5.4. Edit codes

Change PIN or phone code. Make a note of the codes and keep them in a safe place.

- 5.4.1. PIN code
- 5.4.2. Phone code. The factory-set phone code 1234 is used until you change to your own code.

**Menu structure – phone**

The phone code is used to reset the call timer.

5.5. Sound

- 5.5.1. Volume. Adjust the ring tone volume.
- 5.5.2. Ring signal. There are seven different ring tones.
- 5.5.3. Mute radio: On/Off
- 5.5.4. Msg. beep

5.6. Traffic safety

- 5.6.1. Menu lock. Deactivating the menu lock allows access to the entire menu while driving.
- 5.6.2. IDIS. If the IDIS function is deactivated, incoming calls are not delayed, regardless of the driving situation.

5.7. Factory sett.

Reset the system's factory settings.

Type designation	234
Dimensions and weights	235
Engine specifications	237
Engine oil	239
Fluids and lubricants	243
Fuel	245
Catalytic converter	249
Electrical system	250
Type approval	252

01 10

SPECIFICATIONS



11

11 Specifications

Type designation

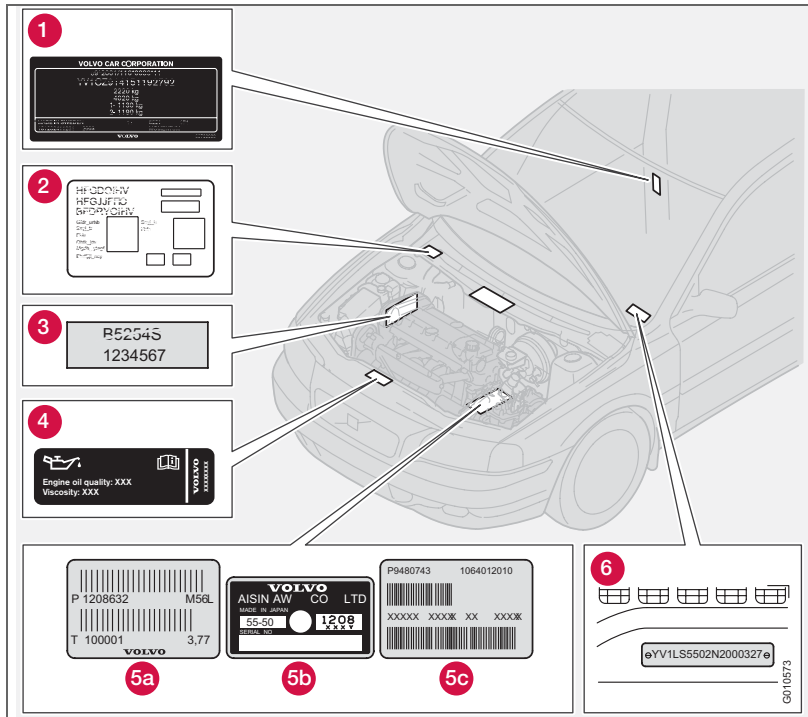

Knowing the car's type designation, vehicle identification and engine numbers can facilitate all contact with a Volvo dealer regarding the car and when ordering spare parts and accessories.

1. Type designation, vehicle identification number, maximum permissible weights, codes for colour and upholstery and type approval number.
2. Decal for parking heater.
3. Engine type designation, component and serial number.
4. Decal for engine oil.
5. Gearbox type designation and serial number:
 - (a) manual gearbox
 - (b), (c) automatic gearbox
6. VIN number (type and model year designation plus chassis number).

Further information on the car is presented in the registration document.

Dimensions and weights

Dimensions

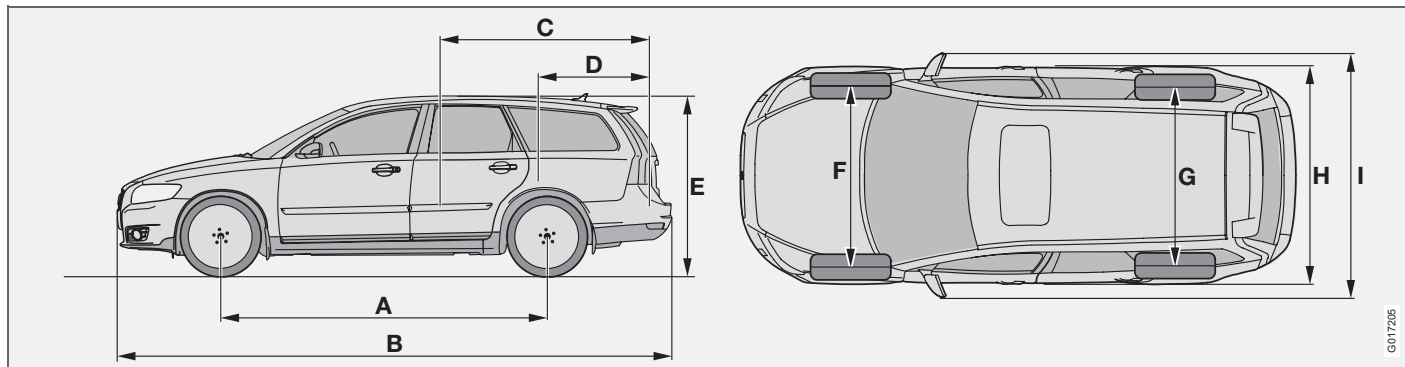

Position in illustration	Dimensions	mm
A	Wheelbase	2640
B	Length	4522
C	Load length, floor, folded seat	1766
D	Load length, floor	989
E	Height	1457
F	Front track	1535
G	Rear track	1531
H	Width	1770
I	Width including door mirrors	2022

11 Specifications

Dimensions and weights

Weights

Kerb weight includes the driver, the fuel tank 90 % full and all fluids. The weight of passengers and accessories, such as a towbar, load carriers, space box etc. and towball load (when a trailer is hitched, see table), influences the payload and must not be included in the kerb weight. Permitted weight (in addition to driver) = Gross vehicle weight – Kerb weight.

WARNING

The car's driving characteristics change depending on how heavily it is loaded and how the load is distributed.

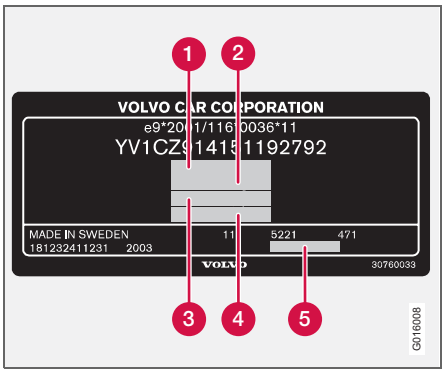

See decal location on page 234.

1. Max. total weight
2. Max. train weight (car+trailer)
3. Max. front axle load
4. Max. rear axle load
5. Equipment level

Maximum load: See registration document.

Max. roof load: 75 kg

Trailer with brakes

Maximum trailer weight kg	Maximum towball load kg
1.6 1200	75
1.6D 1300	
1.8 1300	
2.0 1350	
others 1500	

Trailer without brakes

Maximum trailer weight kg	Maximum towball load kg
700	50

Engine specifications

	1.6	1.8	1.8F	2.0	2.4	2.4i	T5
Engine designation	B4164S3	B4184S11	B4184S8	B4204S3	B5244S5	B5244S4	B5254T7
Output (kW/rpm)	74/6000	92/6000	92/6000	107/6000	103/5000	125/6000	169/5000
(hp/rpm)	100/6000	125/6000	125/6000	145/6000	140/5000	170/6000	230/5000
Torque (Nm/rpm)	150/4000	165/4000	165/4000	185/4500	220/4000	230/4400	320/1500–5000
No. of cylinders	4	4	4	4	5	5	5
Bore (mm)	79	83	83	87	83	83	83
Stroke (mm)	81.4	83.1	83.1	83.0	90.0	90.0	93.2
Swept volume (litres)	1.60	1.80	1.80	1.99	2.44	2.44	2.52
Compression ratio	11.0:1	10.8:1	10.8:1	10.8:1	10.3:1	10.3:1	9.0:1

Engine type designation, component and serial number can be read on the engine, see page 234.

Engine specifications

	1.6D	2.0D	2.4D	D5
Engine designation	D4164T	D4204T	D5244T9 ¹	D5244T8
Output (kW/rpm)	80/4000	100/4000	120/5500	132/4000
(hp/rpm)	109/4000	136/4000	163/5500	180/4000
Torque (Nm/rpm)	240/-	320/2000	340/1750-2750	350/1750-3250
No. of cylinders	4	4	5	5
Bore (mm)	75	85	81	81
Stroke (mm)	88.3	88.0	93.2	93.2
Swept volume (litres)	1.56	2.00	2.40	2.40
Compression ratio	18.3:1	18.5:1	17.0:1	17.0:1

¹Belgium

Engine type designation, component and serial number can be read on the engine, see page 234.

Engine oil

Adverse driving conditions

Check the oil level more frequently for long journeys:

- towing a caravan or trailer.
- in mountainous regions.
- at high speeds.
- in temperatures colder than $-30\text{ }^{\circ}\text{C}$ or hotter than $+40\text{ }^{\circ}\text{C}$.

This can produce abnormally high oil temperature or oil consumption.

Also check the oil level more often if the car is often driven short distances (less than 10 km) when temperatures are low (below $+5\text{ }^{\circ}\text{C}$).

Choose a fully synthetic engine oil for adverse driving conditions. It provides extra protection for the engine.

Volvo recommends Castrol oil products.

**IMPORTANT**

In order to fulfil the requirements for the engine's service intervals all engines are filled with a specially adapted synthetic engine oil at the factory. The choice of oil has been made very carefully with regard to service life, starting characteristics, fuel consumption and environmental impact.

An approved engine oil must be used in order that the recommended service intervals can be applied. Only use a prescribed grade of oil (see the engine compartment decal) for both filling and oil change, otherwise you will risk affecting service life, starting characteristics, fuel consumption and environmental impact.

Volvo Car Corporation disclaims all warranty liability if engine oil of the prescribed grade and viscosity is not used.

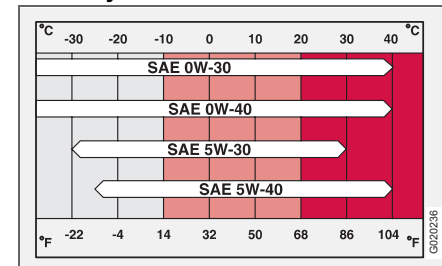
Viscosity chart

11 Specifications

Engine oil

Oil decal

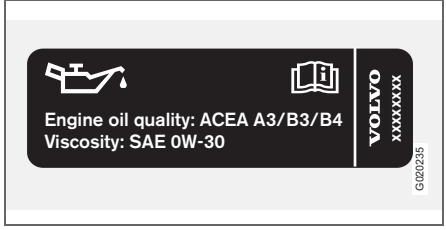

When the oil decal shown alongside here is in the car's engine compartment, the following applies. See location on page 234.

Oil grade: ACEA A3/B3/B4

Viscosity: SAE 0W-30

When driving under adverse conditions, use ACEA A5/B5 SAE 0W-30.

Engine variant		Volume between MIN-MAX (litres)	Volume ¹ (litres)
2.4	B5244S5 ²	1.3	5.8
2.4i	B5244S4 ²		
T5	B5254T7 ²		

¹Including filter change

²Does not apply to Europe, for Europe see page 242.

Engine oil

Oil decal

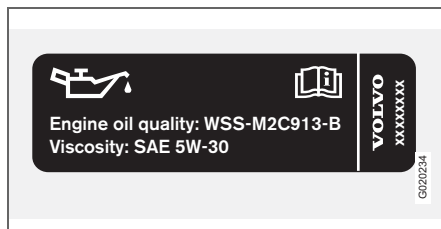

When the oil decal shown alongside here is in the car's engine compartment, the following applies. See location on page 234.

Oil grade: WSS-M2C913-B

Viscosity: SAE 5W-30

When driving under adverse conditions, use ACEA A5/B5 SAE 0W-30.

Engine variant		Volume between MIN-MAX (litres)	Volume ¹ (litres)
1.6	B4164S3	0.75	4,0
1.8	B4184S11		4,3
1.8F	B4184S8		
2.0	B4204S3		
1.6D	D4164T	1.0	3,7
2.0D	D4204T	2.0	5,5

¹Including filter change

11 Specifications

Engine oil

Oil decal

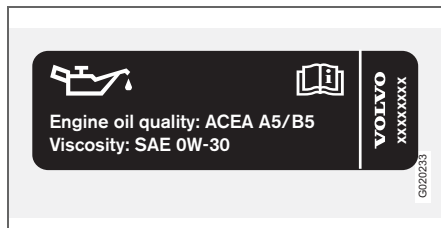

When the oil decal shown alongside here is in the car's engine compartment, the following applies. See location on page 234.

Oil grade: ACEA A5/B5

Viscosity: SAE 0W-30

Engine variant		Volume between MIN-MAX (litres)	Volume ¹ (litres)
2.4	B5244S5 ²	1.3	5.5
2.4i	B5244S4 ²		
T5	B5254T7 ²		
D5	D5244T8	1.5	6
2.4D	D5244T9 ³		

¹Including filter change

²Europe only, for other markets, see page 240.

³Belgium

Fluids and lubricants

Fluid	System	Volume (litres)	Recommended oil grade
Gearbox oil	1.6 Manual 5 speed	2.1	Transmission fluid: WSD-M2C200-C
	1.8 Manual 5 speed	1.9	
	1.6D Manual 5 speed	1.9	
	1.8F Manual 5-speed	1.9	
	2.0 Manual 5-speed	1.9	
	2.0D Manual 6 speed	1.7	Transmission fluid: WSD-M2C200-C
	D5 Automatic gearbox	7.75	Transmission fluid: JWS 3309
	2.4 Automatic gearbox	7.75	Transmission fluid: JWS 3309
	2.4i Manual 5 speed	2.1	Transmission fluid: MTF 97309-10
	2.4i Automatic gearbox	7.75	Transmission fluid: JWS 3309
	T5 Manual 6 speed	2.0	Transmission fluid: MTF 97309-10
	T5 Automatic gearbox	7.75	Transmission fluid: JWS 3309

**IMPORTANT**

The recommended transmission fluid must be used to prevent damage to the gearbox. Do not mix with any other transmission fluid. If the transmission is topped up with a different fluid, contact an authorised Volvo workshop for servicing.

**NOTE**

Under normal driving conditions the gearbox oil does not need changing during its service life. However, it may be necessary under adverse driving conditions, see page 239.

11 Specifications

Fluids and lubricants

Fluid	System	Volume (litres)	Recommended oil grade:
Coolant	5-cyl. manual gearbox	9.5	Coolant with corrosion inhibitor mixed with water, see packaging. The thermostat opens at: petrol engines, 90 °C, diesel engines 82 °C petrol engine (1.6) 82 °C diesel engine (1.6D) 83 °C
	5-cyl. automatic gearbox	10.0	
	4-cyl. Petrol (1.8, 1.8F and 2.0)	7.5	
	4-cyl. Diesel (2.0D)	9.5	
	4-cyl. Petrol (1.6)	6.2	
	4-cyl. Diesel (1.6D)	7.2	
Air conditioning ¹		180–200 grams	Compressor oil PAG
		500–600 grams	Refrigerant R134a (HFC134a)
Brake fluid		0.6	DOT 4+
Power steering		1-1.2	Power steering fluid: WSS M2C204-A or equivalent product with same specifications.
Washer fluid	4-cyl. Petrol/Diesel	4.0	Use a washer antifreeze recommended by Volvo, mixed with water for temperatures below freezing.
	5-cyl. Petrol	6.5	
Fuel tank	See page 245		

¹Weights can vary depending on the engine variant. Contact an authorised Volvo workshop for the exact information.

Fuel

Consumption, emissions and volume

Engine		Gearbox	Consumption litre/100 km	Emissions of carbon dioxide (CO ₂) g/km	Tank volume (litres)
1.6	B4164S3	Manual 5 speed (IB5)	7.2	171	55
1.8	B4184S11	Manual 5 speed (MTX75)	7.3	174	
1.8F	B4184S8	Manual 5 speed (MTX75)	7.4	177	
2.0	B4204S3	Manual 5 speed (MTX75)	7.4	177	62
2.4	B5244S5	Automatic gearbox (AW55-50/51)	9.1	217	
2.4i	B5244S4	Manual 5 speed (M56H)	8.5	203	
		Automatic gearbox (AW55-50/51)	9.1	217	
T5	B5254T7	Manual 6 speed (M66)	8.7	208	
		Automatic gearbox (AW55-50/51)	9.5	227	
T5 AWD		Manual 6 speed (M66)	9.6	229	57
		Automatic gearbox (AW55-50/51)	10.1	241	

11 Specifications

Fuel

Engine		Gearbox	Consumption litre/100 km	Emissions of carbon dioxide (CO ₂) g/km	Tank volume (litres)
1.6D	D4164T (EURO3) (EURO4)	Manual 5 speed (MTX75)	5.0	132	52
2.0D	D4204T (EURO3)	Manual 6 speed (MMT6)	5.7	153	
	(EURO4)		5.8	153	
D5	D5244T8	Automatic gearbox (AW55-51)	7.0	184	60
2.4D	D5244T9 ¹	Automatic gearbox (AW55-51)	7.0	184	

¹Belgium

Engine	Bioethanol	Gearbox	Consumption litre/100 km	Emissions of carbon dioxide (CO ₂) g/km	Tank volume (litres)
1.8F ¹	B4184S8	Manual 5 speed (MTX75)	10.4 ²	-	55

¹Flexifuel can be driven on any 95 octane unleaded petrol, or bioethanol E 85, as well as all possible combinations of these two fuels.

²The car consumes more fuel when driving on bioethanol E 85 than with petrol. This is because bioethanol has a lower energy content than petrol.

Fuel

Fuel consumption and emissions of carbon dioxide

Official fuel consumption figures are based on a standard driving cycle in accordance with EU Directive 80/1268 comb. Fuel consumption figures may change if the car is equipped with extra equipment that affects the car's weight. The manner in which the car is driven and other non-technical factors can also affect fuel consumption. Consumption is higher and power output lower for fuel with an octane rating of 91 RON.

NOTE

Extreme weather conditions, towing a trailer or driving at high altitudes in combination with fuel grade are factors that could affect the car's performance.

Petrol

Most engines can be run with octane ratings of 91, 95 and 98 RON.

- 91 RON must not be used for 4-cylinder engines and should only be used in exceptional cases with other engines.
- 95 RON can be used for normal driving.
- 98 RON is recommended for optimum performance and minimum fuel consumption.

When driving in temperatures above +38 °C, fuel with the highest possible octane rating is recommended for optimum performance and fuel economy.

Petrol – Norm EN 228.

IMPORTANT

Use only unleaded petrol to avoid damaging the catalytic converter. In order for the Volvo warranty to apply, never mix alcohol with petrol, the fuel system could be damaged.

Diesel

Diesel must fulfil the EN 590 or JIS K2204 standards. The diesel engine fuel system is sensitive to contaminants, see page 185.

Bioethanol E85

Do not modify the fuel system or its components, and do not replace components with parts that are not specially designed for use with bioethanol.

WARNING

Methanol must not be used. A decal on the inside of the fuel filler flap shows the correct alternative fuel.

The use of components not designed for bioethanol engines could cause fire, injury or engine damage.

WARNING

Always avoid inhaling fuel fumes and fuel splashing in the eyes.

If fuel gets into your eyes, take out contact lenses if worn and rinse your eyes with plenty of water for at least 15 minutes and seek medical attention.

Never swallow fuel. Fuel such as petrol, bioethanol and mixtures of the two are highly toxic and could cause permanent injury or be fatal if swallowed. Seek medical attention immediately if fuel has been swallowed.

Fuel

 **IMPORTANT**

The use of other fuels could cause engine damage and impaired performance. It also invalidates Volvo's warranties as well as any supplementary service agreement.

Refuel with petrol before long-stay parking to avoid the risk of corrosion. Small quantities of contaminants could be present in bioethanol E85.

Reserve fuel can

The reserve fuel can should be filled with petrol, see page 123.

 **WARNING**

Ethanol is sensitive to sparks, and explosive gases could form in the reserve fuel can if it is refuelled with ethanol.

11

Catalytic converter**General**

The purpose of the catalytic converter is to purify exhaust gases. It is located in the flow of exhaust gasses close to the engine so that it quickly reaches operating temperature. The catalytic converter consists of a monolith (ceramic or metal) with channels. The channel walls are lined with a thin layer of platinum, rhodium and palladium. These metals act as catalysts, i.e. they participate in and accelerate a chemical reaction without being used up themselves.

Lambda-sond™ oxygen sensor

The Lambda-sond is part of a control system intended to reduce emissions and improve fuel economy.

An oxygen sensor monitors the oxygen content of the exhaust gases leaving the engine. This value is fed into an electronic system that continuously controls the injectors. The ratio of air to fuel is continuously adjusted. These adjustments create optimal conditions for efficient combustion, and together with the three-way catalytic converter reduce harmful emissions (hydrocarbons, carbon monoxide and nitrous oxides).

11 Specifications

Electrical system

General

12 V system with a voltage-regulated alternator. Single pole system in which the chassis and engine block are used as conductors.

Battery

Voltage	12 V	12 V	12 V
Cold start capacity (CCA)	590 A	600 A ¹	700 A ²
Reserve capacity (RC)	100 min	120 min	135 min
Capacity (Ah)	60	70	80

¹Cars equipped with High Performance audio system.

²Cars equipped with diesel, keyless drive, audio system Premium Sound, fuel-driven heater or RTI.

If the battery is changed, replace it with a battery of the same cold start capacity and reserve capacity as the original (see the decal on the battery).

Electrical system

Bulbs

Lighting	Output W	Type
Dipped beam	55	H7
Main beam (specifically for halogen)	55	H9
Extra main beam (specifically for Bi Xenon and ABL)	55	H7
Brake lights, reversing lamps, rear fog lamp	21	P21W
Front direction indicators (specifically for Bi Xenon and halogen), rear direction indicators	21	PY21W
Front direction indicators (specifically for ABL)	24	PY24W
Rear position/parking and side marker lamps (upper socket)	5	P21/5W
Rear position/parking lamps (lower socket)	5	R5W
Courtesy lighting, cargo area lighting, number plate lighting	5	C5W
Vanity mirror	1.2	Tubular lamp
Front position/parking lamps, front side marker lamps	5	W5W
Fog lamps	35	H8
Glovebox lighting	3	Tubular lamp

11 Specifications

Type approval

Remote control system

Country	
A, B, CY, CZ, D, DK, E, EST, F, FIN, GB, GR, H, I, IRL, L, LT, LV, M, NL, P, PL, S, SK, SLO	 ¹
IS, LI, N, CH	
HR	
ROK	Delphi 2003-07-15, Germany R-LPD1-03-0151
BR	 ² 
RC	 ETC093LPD0155

¹ Delphi hereby certifies that this remote control system conforms to the essential characteristic requirements and other relevant regulations of directive 1999/5/EC.

² USA-FCC ID: KR55WK48952, KR55WK48964

NOTE:
This remote control system is in conformity with section 15 in the FCC Rules. The function refers to the following two conditions:

1. This system must not cause any harmful interference.
2. This system accepts interference received, including interference that affects the system negatively.

Important!
Modifications to the system not approved by the manufacturer could lead to the remote control system ceasing to work.

Siemens VDO
5WK48891
Tested to conform with FCC characteristic requirements for use in a passenger car.

11



A

A/C	
electronic climate control	77
manual climate control	73
ABL, active headlamps	47
ABS	131
ABS fault	41
AC	72
Active Bi-Xenon Lights	47
Active headlamps	47
Active Yaw Control	133
Additional heater	80
Adjustment, clock	65
AF – automatic frequency update	217
Air conditioning	72
ECC	75
general	70
Air distribution	78
ECC	76
Air quality system, ECC	76
Air vents	71
Airbag	
deactivation	19
driver's and front passenger side	16
Alarm	
alarm light	112
alarm signals	113
arming	112
automatic alarm activation	112
deactivating a triggered alarm	113
disarming	112
general	112
testing the alarm system	115
Alarm, radio functions	215
All-wheel drive	130
Approach light duration	
active lamps	61
setting	66
Audio volume	
audio system	211
media player	211
Audio, see also Sound	211
AUTO	
climate control settings	75
preset storage	214
AUTO CLIMATE	75
Auto volume control	213
Automatic car wash	174
Automatic dimming	59
Automatic gearbox	129
safety systems	128
towing and recovery	142
trailer	145, 146
Automatic locking	109
Automatic relocking	108
Autostart	121
Average fuel consumption	50
AWD	130

B

Backrest	
rear seat, tipping	92
Bass speaker	213
Battery	
care	192
jump starting	144
overload	119
replacement	193
replacing the battery in the remote	
control	107
symbols on the battery	192
Bioethanol E85	247
Blind spot (BLIS)	138
Bonnet	184
Booster cushion	
lowering	31
raising	30
Booster cushion, integrated	30
Brake fluid, checking and topping up	189
Brake lights	48
Brake system	131, 189
Brakes	
brake lights	48
emergency brake light, EBL	48
handbrake	56
Bulb holder	
location of the bulbs	199
number plate lighting	199

removal	198
Bulbs	
replacement	194
specifications	251
C	
<hr/>	
Call	
functions during an ongoing call	226
phone volume	225
Call waiting	224
Calls	
making and receiving	224
Car care, leather upholstery	176
Car settings	66
Car upholstery	176
Car wash	174
Cargo area	
bag holder	97
cargo cover	94
electrical socket	97
lighting	86
load retaining eyelets	96
loading	154
safety grille	94
safety net	95
Cargo cover	94
Catalytic converter	249
recovery	142
CD discs	
storage compartment	89

CD functions	218
Centre rear head restraint	92
Checks	
fluids and oils	183, 186
Child	
child seats and airbags	27
Children	
child safety locks	111
child seats and side airbags	20
position in car, table	29
safety	30
safety equipment	27
Cigarette lighter socket	
front seat	45
Clean inside and out	8
Cleaning	
automatic car wash	174
car wash	174
seatbelts	176
upholstery	176
water-repellent surface	175
Climate	
personal preferences	65
Climate control	
general	70
Climate control settings	
AUTO	75
Clock, adjustment	65
Clutch fluid, checking & topping up	189

Collision	
collision sensors	22
crash mode	26
IC	22
inflatable curtain	22
Colour code, paint	177
Combined instrument panel	39
Compass	59
calibration	59
Condensation	185
Control panel	
personal preferences	64
Control panel in driver's door	
operation	57
Coolant, checking and topping up	188
Cooling system	118
Crash, see Collision	22
Cruise control	53
D	
<hr/>	
Deadlocks	110
temporary deactivation	110
temporary disconnection of alarm detectors	114
Defroster	73
door mirrors	73
rear window	73
Designation of dimensions	158
Diesel	185
engine preheater	41

- Diesel filter 185
 Diesel particle filter 121
 Dimensions 235
 Dipped beam 46, 49
 Direction indicators 49
 Disc text 219
 Display
 messages 43, 44
 Display lighting 47
 Dolby Surround Pro Logic II 210, 213
 Door mirrors 61
 Driver's door control panel
 overview 38
 Driving
 adverse driving conditions 182
 cooling system 118
 economical 118
 slippery driving conditions 118
 with open tailgate 118
 with trailer 145
 Driving in water 118
 DSTC, see also Stability control system ... 133
 deactivating/activating 133
 symbol 41
- E**
-
- ECC, electronic climate control 71
 ECO pressure
 fuel economy 162
 table 163
- Economical driving 118
 Electrical socket
 cargo area 97
 centre console 45
 rear seat 45
 Electronic immobiliser 100
 Emergency calls 222
 Emergency puncture repair 167
 Emission control 8
 Emissions 245
 carbon dioxide 247
 Emissions system
 fault indicator 41
 Engine 184
 Engine block heater 123
 Engine compartment 184
 Engine oil 186
 capacities 240, 241, 242
 changing 186
 driving under adverse driving
 conditions 239
 filter 186
 oil grade 239
 oil pressure 42
 Engine specifications 237
 Entry, keyless 66
 Environmental philosophy 7
 EON – Enhanced Other Networks 217
 Equalizer 213
- Expectant mothers
 safety 13
- F**
-
- Fan 72
 ECC 75
 Fast-wind 219
 Flexifuel 123
 Floor mats 84
 Fluids and oils
 checks 183, 186
 Fluids, capacities 243, 244
 Fog lamps, On/Off 47
 frequency update, automatic 217
 Fuel
 consumption 7, 245
 fuel consumption, display 50
 fuel economy 162
 fuel filter 185
 fuel system 185
 level indicator 41
 parking heater 80
 refuelling 120
 Fuel gauge 39
 Fuse table
 fuses in the engine compartment 203
 fuses in the passenger compartment .. 206
 Fuses
 changing 201
 general 201

relay/fuse box in the engine compartment	202
relay/fuse box in the passenger compartment	205

G

Gearbox	
automatic	129
manual	125
Global opening	108
Glovebox	89
locking	102
Gross vehicle weight	236

H

Handbrake	56
Hazard warning flashers	55
Headlamp pattern	155
Headlamps	
headlamp washers	51
Off/On	46
Heating	
front seats	73, 77
Homesafe light duration	49, 61
setting	66

I

IDIS	222
Ignition keys	122
IMEI number	227

Immobiliser	100, 122
"Important!" texts	6
Incoming calls	224
Information display	43
Infotainment	
menus	210
Instrument lighting	46
Instrument overview	
left-hand drive	34
right-hand drive	36
Integrated booster cushion	30
Interior rearview mirror	59
Intermittent wiping	51
iPod, connection	212
ISOFIX	
fixture system	31

J

Jump starting	144
---------------------	-----

K

Kerb weight	236
Key	100
keyless lock and ignition system	104
remote control	100
Key blade	
active locks	103
Keyless drive	104
starting the car	124
Keyless entry	66

Kick-down	
automatic gearbox	128

L

Lambda-sond	249
Leather upholstery, washing instructions .	176
Lighting	
automatic lighting, dipped beam	46
automatic lighting, passenger compartment	86
bulb replacement, general	194
bulbs, specifications	251
cargo area	86
dipped beam	46
display lighting	47
exterior	46
front fog lamps	47
headlamp levelling	46
homesafe light duration	49, 61
in passenger compartment	86
instrument lighting	47
lighting panel	46
main/dipped beam	49
position/parking lamps	46
reading lamps	86
rear fog lamp	47
Lighting, bulb replacement	
cargo area	200
courtesy lighting	199
dipped beam	195
direction indicators	196

- fog lamp 197
- front 194
- location of the bulbs in the bulb holder 199
- main beam 195
- parking lamps 196
- position lamps 196
- rear lamp 198
- side marker lamps 197
- vanity mirror 200
- Lights
 - main beam "flash" 49
- Loading
 - cargo area 96
 - general 154
 - load capacity 154
- Locking 108
 - from inside 109
 - from outside 108
 - unlocking 108
- Lubricants, capacities 243, 244
- M**
- Main beam 49
 - Off/On 46
 - switching and flashing 49
- Maintenance
 - rustproofing 178
 - self-maintenance 183
- Making calls 224
- Manual gearbox 125
- Menu structure
 - media player 220
 - phone, menu options 229
 - phone, overview 228
- Menus
 - audio system 210
- Messages in the information display 43
- Misting
 - rear window 73
 - removing with defroster function 73, 76
 - timer function, A/C 73
 - timer function, ECC 76
 - treating the windows 70
- N**
- NEWS 216
- News broadcast 216
- "Note" texts 6
- O**
- Oil, see also Engine oil
 - oil pressure 42
- Outside temperature gauge 39
- Oxyhydrogen gas 144
- P**
- PACOS 18
- Paint
 - paintwork damage and touching up ... 177
- Paintwork
 - colour code 177
- Parking assistance 135
 - sensors for parking assistance 137
- Parking brake 42, 56
- Parking heater
 - battery and fuel 80
 - general 79
 - parking on a hill 79
 - time setting 80
- Parking lamps 46
- Passenger compartment
 - lighting 86
- Passenger compartment filter 70
- Personal preferences 65
 - approach light duration 66
 - auto blower adjust 65
 - automatic locking 66
 - doors unlock 66
 - homesafe light duration 66
 - keyless entry 66
 - lock confirm, light 66
 - recirculation timer 65
 - unlock confirm, light 66
- Petrol grade 247
- Phone 223
 - calling from the phone book 226
 - On/Off 224
 - standby mode 224
 - text input 225

Phone book	
handling numbers	225
Pinch protection, sunroof	64
Polishing	175
Position lamps	46
Power seat	85
Power steering fluid, checking and topping up	190
Power windows	57
blocking	58
passenger seat	58
rear seat	58
Programme functions	215
PTY – Programme type	216
Putting calls on hold	224

R

Radio		electrically retractable	61
radio settings	214	interior	59
radio stations	214	Recirculation	72
Radio text	217	ECC	76
Rain sensor	52	Recovery	142
Random, CD and audio files	219	Refrigerant	70
RDS functions	215	Refuelling	
resetting	217	fuel cap	120
Reading lamps	86	refuelling	120
Rearview mirrors		Refuse calls	224
compass	59	REG – Regional radio programmes	217
door	61	Relay/fuse box	
		in the engine compartment	202
		in the passenger compartment	205
		Remote control	100
		functions	100
		keyless drive	104
		replacing the battery	107
		Remote control system, type approval	252
		Reverse gear inhibitor	
		five-speed	125
		six-speed, petrol	126
		Rustproofing	178

S

Safety	12	SCAN	
safety systems, table	25	CD and audio files	219
Safety grille	94	radio stations	215
Safety net	95	Seat	
		key memory	85
		power seat	85
		Seatbelt	12
		pregnancy	13
		rear seat	13
		Seatbelt reminder	13
		Seats	
		manual setting	84
		Service programme	182
		Settings, see Personal preferences	65
		Side airbags	20
		SIM card	222
		SIPS bags	20
		SMS	
		read	227
		write	227
		Soot filter	44, 121
		soot filter full	121
		Sound	
		audio settings	211
		audio source	211
		Spare wheel	164
		temporary spare	160
		Speed classes, tyres	158
		Speed dial	226

- Speedometer39
- Spin control 133
- SRS system
 general17
 switch19
- Stability control system 133
- Stability system
 indication41
- Stains 176
- Standby mode, phone224
- Starting from cold
 automatic gearbox 129
- Starting the engine 121
 keyless drive 124
- STC 133
- Steering lock 122
- Steering wheel
 adjustment55
 cruise control53
 keypad223
 keypad left-hand side53
 keypad right-hand side54
- Stone chips and scratches 177
- Storage compartment88, 89
 CD discs89
- Storage spaces in the passenger
 compartment88
- Storing stations, manual and automatic ...214
- Subwoofer213
- Sunroof 63
 closing with remote control 64
 pinch protection 64
 sunscreen 64
- Sunscreen, sunroof 64
- Surround 210, 213
- Symbols 134
 indicator symbols 41
 warning symbols 40
- T**
- Tachometer 39
- Tailgate
 driving with open tailgate 118
 locking/unlocking 100, 108
- Tank volume 245
- Temperature
 actual temperature 71
 passenger compartment, electronic
 climate control 77
 passenger compartment, manual climate
 control 74
- Ticket clip 89
- Timer
 A/C 73
 ECC 76
- Towbar, see Towing equipment 147
- Towing 142
- Towing equipment
 general 147
 installation 149
 removing 152
 specifications 148
- Towing eye 142
- TP – traffic information 215
- Traction control system 133
- Traffic information 215
- Trailer
 cable 147
 driving with a trailer 145
 trailer weight 236
- Trip computer 50
- Trip meter 39
- Tuning 214
- Type approval, remote control system 252
- Type designation 234
- Tyres
 designation of dimensions 158
 direction of rotation 161
 driving characteristics 158
 ECO pressure 163
 general 158
 pressure 162
 puncture repair 167
 speed classes 158
 summer and winter wheels 161
 tread wear indicators 159
 winter tyres 159

U	
<hr/>	
Unlocking	
from inside	109
from outside	108
keyless	108
settings	66
tailgate	108
USB, connection	212
V	
<hr/>	
Vehicle data	182
Ventilation	71
Volume	
auto volume control	213
phone/media player	225
programme types	217
Volume, see also Audio volume	211
W	
<hr/>	
Warning lamp	
stability and traction control system	133
Warning symbol, airbag system	15
"Warning!" texts	6
Warning triangle	164
Washer	
rear window	52
Washer fluid, topping up	188
Washers	
windscreen and headlamps	51
Washing the car	174
Water-repellent surface	
cleaning	175
Waxing	175
Wheels	
fitting	166
removal	165
rims	160
Whiplash injury WHIPS	23
WHIPS	23
child seat/booster cushion	23
Windscreen wipers	
rain sensor	52
Windscreen wipers and washers	51
Winter driving	121
Winter tyres	159
Wiper	
rear window	52
Wiper blades	
replacing, rear window	191
replacing, windscreen	191

Volvo. for life

VOLVO

Volvo Car Corporation TP 9176 (English), AT 0720, Printed in Sweden, Göteborg 2007. Copyright © 2000-2007 Volvo Car Corporation